

#### INTRODUCTION:

Adam Tech SMT PLCC Series Sockets are low profile, thin wall sockets designed to convert plastic leaded chips to a thru-hole PCB format on a .100" centerline grid. They conform to JEDEC MS 016 and MS 018 pin count standards. Adam Tech's superior precision stamped contact design provides consistent, high retention contacts for all size chips. Chip exchanges or replacements are easily made with Adam Tech's chip remover part no. PLCC-EXT.

#### FEATURES:

- Full range of sizes from 20P ~ 100P
- Consistent, uniform high retention contacts
- Compatible with wide range of chip sizes
- No solder wicking design
- Hi Temp PPS insulator
- Open frame design for viewable solder joints

#### MATING PLASTIC LEADED CHIPS:

All EIA / JEDEC compliant PLCC

#### SPECIFICATIONS:

##### Material:

Standard Hi-Temp insulator: PPS, Glass reinforced, rated UL94V-0  
Insulator Color: Brown  
Contacts: Phosphor Bronze

##### Contact Plating:

Tin over copper underplate overall

##### Electrical:

Operating voltage: 250V AC max.  
Current rating: 1 Amp max.  
Contact resistance: 30 mΩ max. initial  
Insulation resistance: 1000 MΩ min.  
Dielectric withstanding voltage: 500V AC for 1 minute

##### Mechanical:

Insertion force: 6.35 oz max.  
Withdrawal force: 1.0 oz min

##### Temperature Rating:

Operating temperature: -55°C to +105°C  
Soldering process temperature: 260°C

#### PACKAGING:

Anti-ESD plastic tubes

#### APPROVALS AND CERTIFICATIONS:

UL Recognized & CSA Certified, File no. E224053

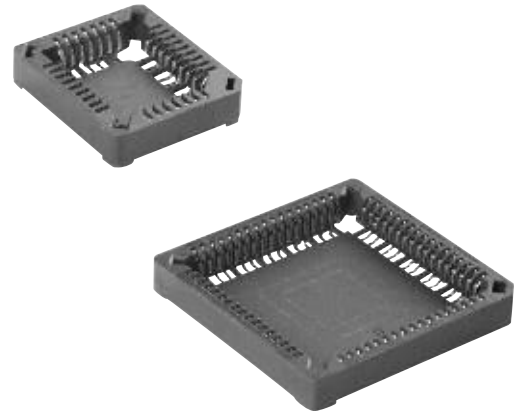

#### ORDERING INFORMATION

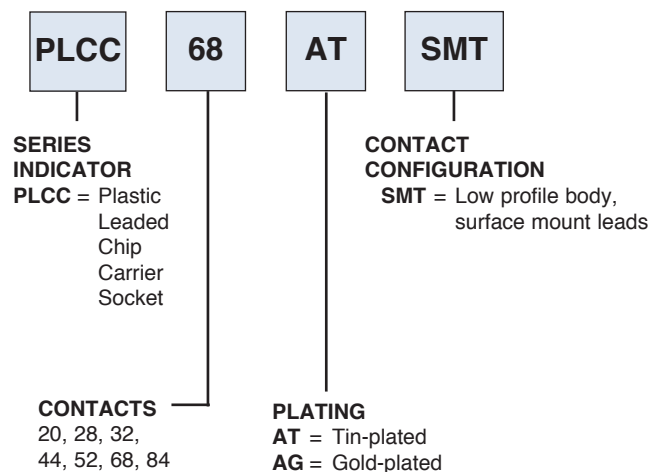

#### OPTIONS:

Add designator(s) to end of part number  
**P** = With polarizing pegs  
**TR** = Tape and reel packaging



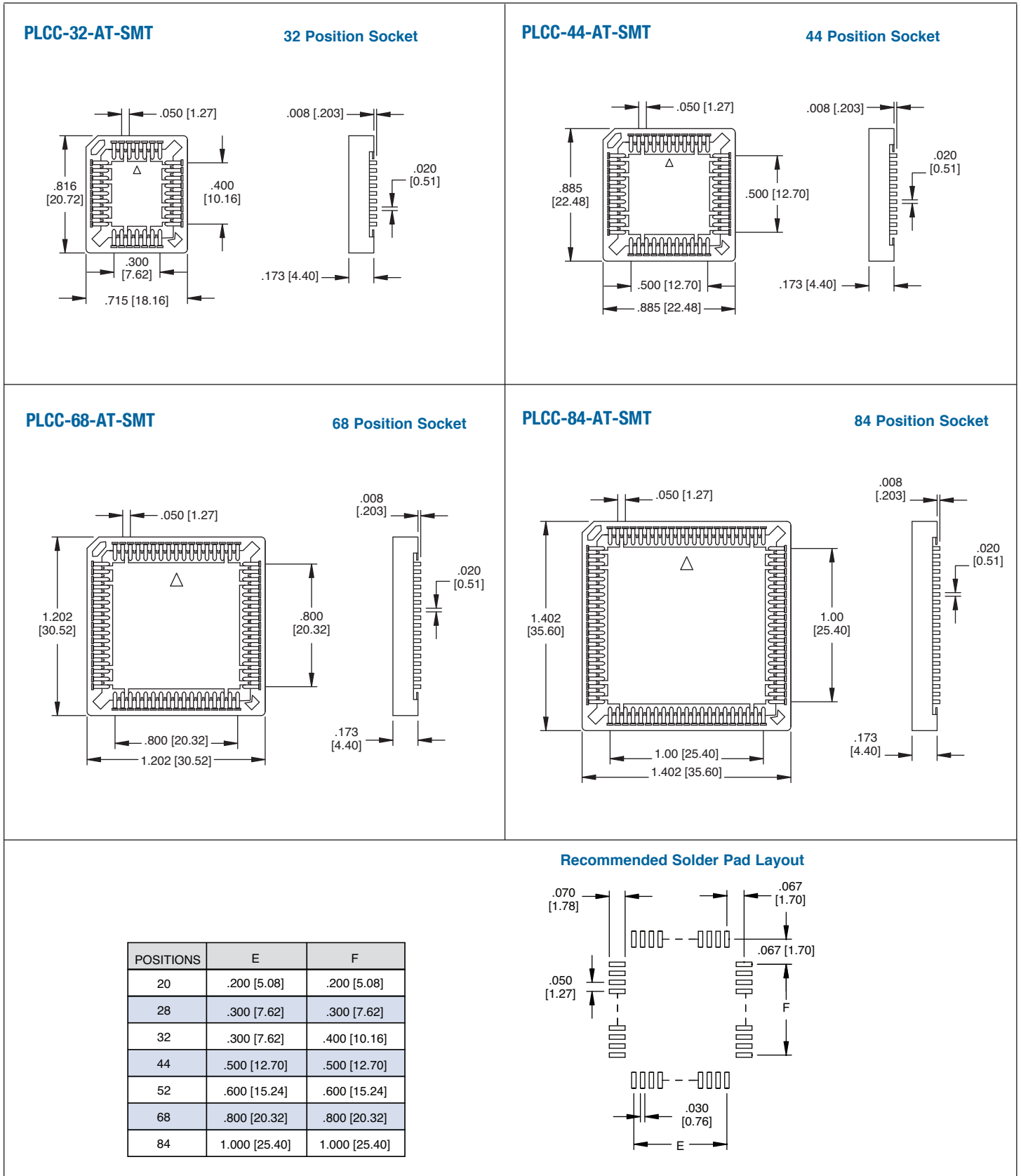

#### INTRODUCTION:

Adam Tech PLCC Series Sockets are designed to convert plastic leaded chips to a thru-hole PCB format on a .100" centerline grid. They conform to JEDEC MS 016 and MS 018 pin count standards. Adam Tech's superior precision stamped contact design provides consistent, high retention contacts for all size chips. Chip exchanges or replacements are easily made with Adam Tech's chip remover part no. PLCC-EXT.

#### FEATURES:

- Full range of sizes from 20P ~ 100P
- Consistent, uniform high retention contacts
- Compatible with wide range of chip sizes
- No solder wicking design
- Hi Temp PPS insulator version available

#### MATING PLASTIC LEADED CHIPS:

All EIA / JEDEC plastic leaded chips

#### SPECIFICATIONS:

##### Material:

Standard Insulator: PBT, Glass reinforced, rated UL94V-0  
Optional Hi-Temp insulator: PPS  
Insulator Color: Black (Brown for PPS)  
Contacts: Phosphor Bronze

##### Contact Plating:

Tin over copper underplate overall

##### Electrical:

Operating voltage: 250V AC max.  
Current rating: 1 Amp max.  
Contact resistance: 30 mΩ max. initial  
Insulation resistance: 1000 MΩ min.  
Dielectric withstanding voltage: 500V AC for 1 minute

##### Mechanical:

Insertion force: 6.35 oz max.  
Withdrawal force: 1.0 oz min

##### Temperature Rating:

Operating temperature: -20°C to +85°C  
Soldering process temperature:  
Standard insulator: 235°C  
Hi-Temp insulator: 260°C

#### PACKAGING:

Anti-ESD plastic tubes

#### APPROVALS AND CERTIFICATIONS:

UL Recognized & CSA Certified, File no. E224053



#### ORDERING INFORMATION

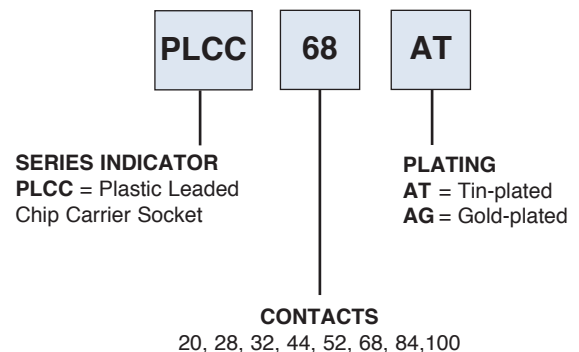

#### OPTIONS:

Add designator(s) to end of part number  
HT = Hi-Temp Polyphenylene Sulfide (PPS) Insulator  
Material for hi-temp soldering process up to 260°C

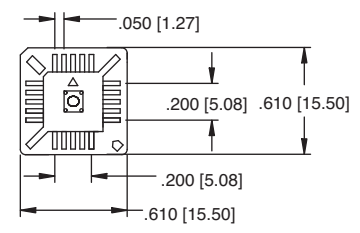
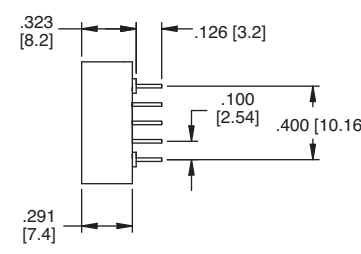
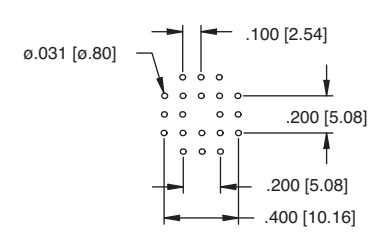
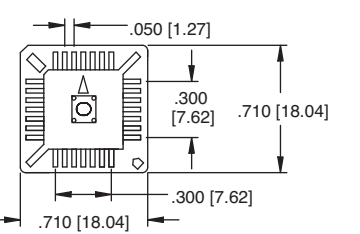
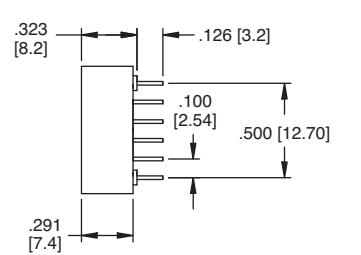
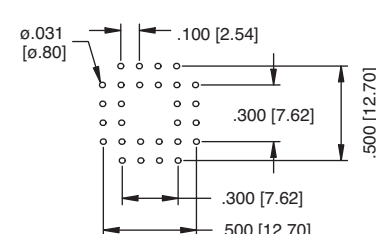
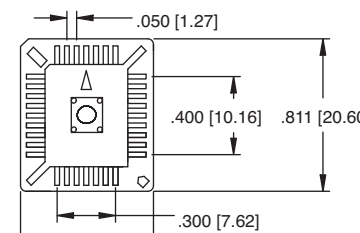
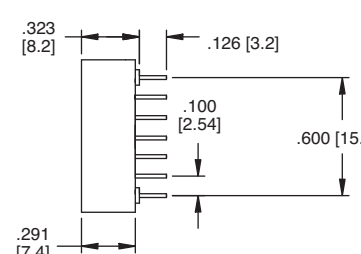
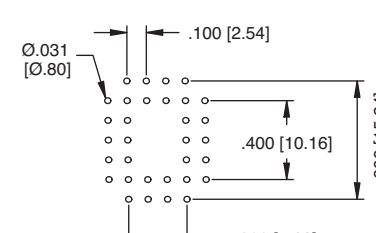
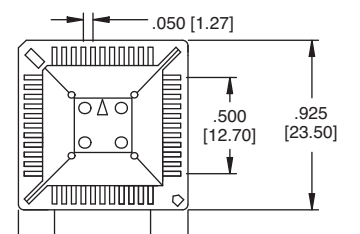
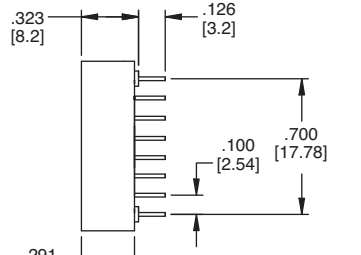
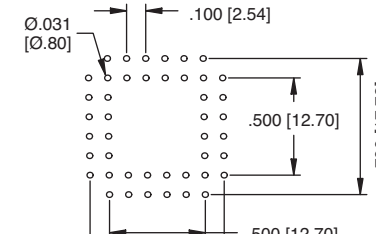

<p><b>PLCC-20-AT</b></p> 	<p><b>20 Position Socket</b></p> 	<p><b>20 Position Socket</b></p>  <p><b>Recommended PCB Layout</b></p>
<p><b>PLCC-28-AT</b></p> 	<p><b>28 Position Socket</b></p> 	<p><b>28 Position Socket</b></p>  <p><b>Recommended PCB Layout</b></p>
<p><b>PLCC-32-AT</b></p> 	<p><b>32 Position Socket</b></p> 	<p><b>32 Position Socket</b></p>  <p><b>Recommended PCB Layout</b></p>
<p><b>PLCC-44-AT</b></p> 	<p><b>44 Position Socket</b></p> 	<p><b>44 Position Socket</b></p>  <p><b>Recommended PCB Layout</b></p>

**PLCC-52-AT**

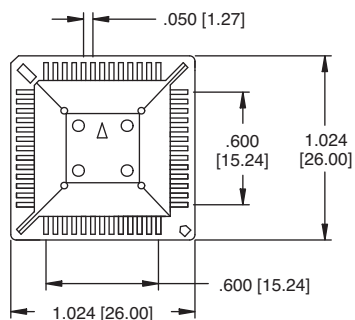

**52 Position Socket**

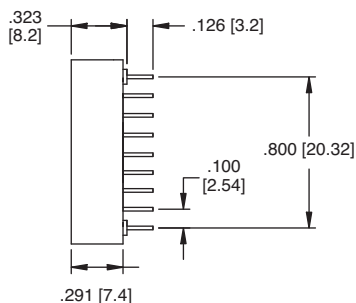

**52 Position Socket**

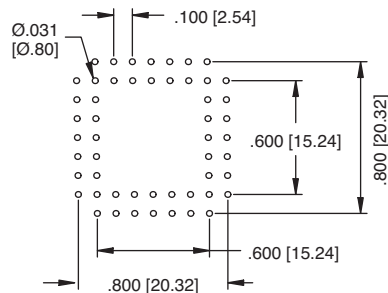

**Recommended PCB Layout**

**PLCC-68-AT**

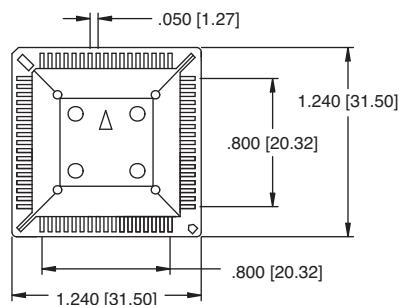

**68 Position Socket**

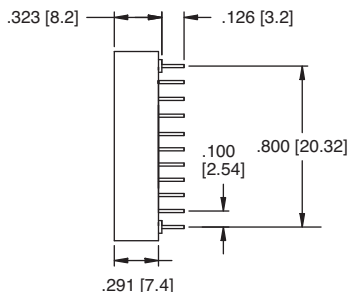

**68 Position Socket**

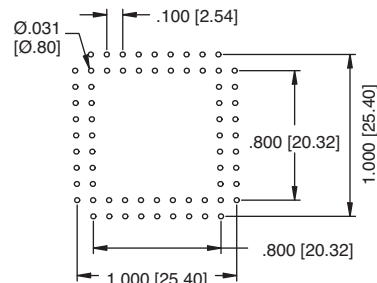

**Recommended PCB Layout**

**PLCC-84-AT**

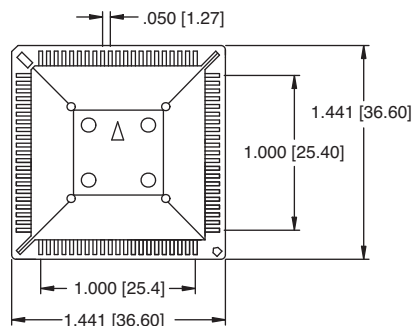

**84 Position Socket**

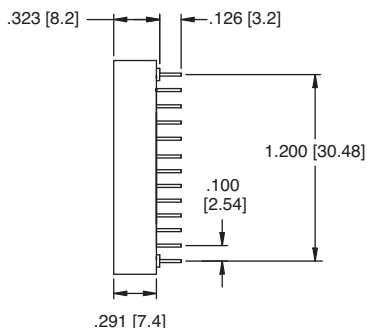

**84 Position Socket**

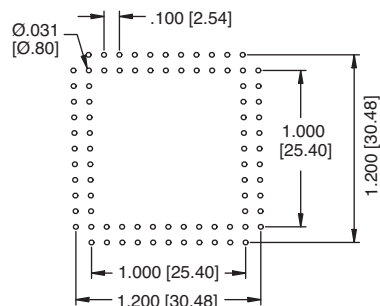

**Recommended PCB Layout**