

FEATURES

- 5.0V, 3.3V, 3.0V and 2.5V Versions
- High Accuracy Output Voltage
- Extremely Low Quiescent Current
- Low Dropout Voltage
- Extremely Tight Load and Line Regulation
- Very Low Temperature Coefficient
- Current and Thermal Limiting
- Needs Minimum Capacitance (1 μ F) for Stability
- Unregulated DC Positive Transients 60V

ADDITIONAL FEATURES (AMS2951 ONLY)

- 1.24V to 29V Programmable Output
- Error Flag Warning of Voltage Output Dropout
- Logic Controlled Electronic Shutdown

APPLICATIONS

- Battery Powered Systems
- Portable Consumer Equipment
- Cordless Telephones
- Portable (Notebook) Computers
- Portable Instrumentation
- Radio Control Systems
- Automotive Electronics
- Avionics
- Low-Power Voltage Reference

GENERAL DESCRIPTION

The AMS2950 and AMS2951 are micropower voltage regulators ideally suited for use in battery-powered systems. These devices feature very low quiescent current (typ.75 μ A), and very low dropout voltage (typ.45mV at light loads and 380mV at 150mA) thus prolonging battery life. The quiescent current increases only slightly in dropout. The AMS2950/AMS2951 has positive transient protection up to 60V and can survive unregulated input transient up to 20V below ground.

The AMS2950 and AMS2951 were designed to include a tight initial tolerance (typ. 0.5%), excellent load and line regulation (typ. 0.05%), and a very low output voltage temperature coefficient, making these devices useful as a low-power voltage reference.

The AMS2950 is offered in the 3-pin TO-92 package. AMS2951 is available in 8-pin plastic SOIC and DIP packages and offers three major additional system features. An error flag output warns of a low output voltage, often due to failing batteries on input. The AMS2951 also features the logic-compatible shutdown input which enables the regulator to be switched on and off. The AMS2951 device may be pin-strapped for a 5.0V, 3.3V, 3.0V or 2.5 output, or programmed from 1.24V to 29V with an external pair of resistors.

ORDERING INFORMATION

PACKAGE TYPE			OPERATING TEMP. RANGE
TO-92	8 LEAD PDIP	8 LEAD SOIC	
AMS2950ACN-X	AMS2951ACP-	AMS2951ACS-X	IND.
AMS2950CN-X	AMS2951CP-X	AMS2951CS-X	IND.

X = 3.3V, 3.0V, 2.5V

PIN CONNECTION

8L SOIC/ 8L PDIP

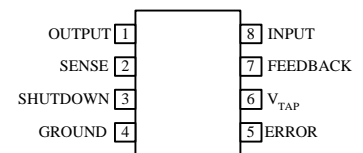

Top View

TO-92

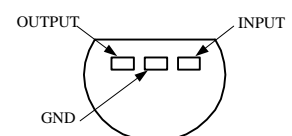

Bottom View

AMS2950/AMS2951

ABSOLUTE MAXIMUM RATINGS (Note 1)

Input Supply Voltage	-0.3 to +30V
SHUTDOWN Input Voltage, Error Comparator Output Voltage,(Note 9)	
FEEDBACK Input Voltage	-1.5 to +30V
(Note 9) (Note 10)	
Power Dissipation	Internally Limited
Junction Temperature	+150°C
Storage Temperature	-65°C to +150°C
Soldering Temperature (25 sec)	265°C

OPERATING RATINGS (Note 1)

Max. Input Supply Voltage	30V
Junction Temperature Range (T _J) (Note 8)	
AMS2950AC-XX, AMS2950C-XX, AMS2951AC-XX, AMS2951C-XX	-40°C to +125°C

ELECTRICAL CHARACTERISTICS at V_S=V_{out}+1V, T_a=25°C, unless otherwise noted.

Parameter	Conditions (Note 2)	AMS2950AC AMS2951AC			AMS2950C AMS2951C			Units
		Min.	Typ.	Max.	Min.	Typ.	Max.	
2.5 V Versions (Note 16)								
Output Voltage	T _J = 25°C (Note 3)	2.488	2.5	2.512	2.475	2.5	2.525	V
	-25°C ≤ T _J ≤ 85°C	2.475	2.5	2.525	2.450	2.5	2.550	V
	Full Operating Temperature Range	2.470	2.5	2.530	2.440	2.5	2.560	V
Output Voltage	100 μA ≤ I _L ≤ 150 mA T _J ≤ T _{JMAX}	2.463	2.5	2.537	2.448	2.5	2.562	V
3.0 V Versions (Note 16)								
Output Voltage	T _J = 25°C (Note 3)	2.985	3.0	3.015	2.970	3.0	3.030	V
	-25°C ≤ T _J ≤ 85°C	2.970	3.0	3.030	2.955	3.0	3.045	V
	Full Operating Temperature Range	2.964	3.0	3.036	2.940	3.0	3.060	V
Output Voltage	100 μA ≤ I _L ≤ 150 mA T _J ≤ T _{JMAX}	2.958	3.0	3.042	2.928	3.0	3.072	V
3.3 V Versions (Note 16)								
Output Voltage	T _J = 25°C (Note 3)	3.284	3.3	3.317	3.267	3.3	3.333	V
	-25°C ≤ T _J ≤ 85°C	3.267	3.3	3.333	3.251	3.3	3.350	V
	Full Operating Temperature Range	3.260	3.3	3.340	3.234	3.3	3.366	V
Output Voltage	100 μA ≤ I _L ≤ 150 mA T _J ≤ T _{JMAX}	3.254	3.3	3.346	3.221	3.3	3.379	V
5.0 V Versions (Note 16)								
Output Voltage	T _J = 25°C (Note 3)	4.975	5.0	5.025	4.95	5.0	5.05	V
	-25°C ≤ T _J ≤ 85°C	4.95	5.0	5.050	4.925	5.0	5.075	V
	Full Operating Temperature Range	4.94	5.0	5.06	4.90	5.0	5.10	V
Output Voltage	100 μA ≤ I _L ≤ 150 mA T _J ≤ T _{JMAX}	4.925	5.0	5.075	4.88	5.0	5.12	V
All Voltage Options								
Output Voltage Temperature Coefficient	(Note 12) (Note 4)		20			50		ppm/°C
Line Regulation (Note 14)	6V ≤ V _{in} ≤ 30V (Note 15)		0.03	0.1		0.04	0.2	%
Load Regulation (Note 14)	100 μA ≤ I _L ≤ 150 mA		0.04	0.1		0.1	0.2	%

AMS2950/AMS2951

ELECTRICAL CHARACTERISTICS (Note 2) (Continued)

PARAMETER	CONDITIONS (Note 2)	AMS2950AC AMS2951AC			AMS2950C AMS2951C			Units
		Min.	Typ.	Max.	Min.	Typ.	Max.	
Dropout Voltage (Note 5)	$I_L = 100\mu\text{A}$		50	80		50	80	mV
	$I_L = 150\text{mA}$		380	450		380	450	mV
Ground Current	$I_L = 100\mu\text{A}$		75	120		75	120	μA
	$I_L = 150\text{mA}$		8	12		8	12	mA
Current Limit	$V_{\text{out}} = 0$		160	200		160	200	mA
Thermal Regulation	(Note 13)		0.05	0.2		0.05	0.2	%/W
Output Noise, 10Hz to 100KHz	$C_L = 1\mu\text{F}$		430			430		$\mu\text{V rms}$
	$C_L = 200\mu\text{F}$		160			160		$\mu\text{V rms}$
	$C_L = 13.3\mu\text{F}$ (Bypass = 0.01 μF pins 7 to 1(AMS2951))		100			100		$\mu\text{V rms}$
8-Pin Versions only		AMS2951AC			AMS2951C			
Reference Voltage		1.22	1.235	1.25	1.21	1.235	1.26	V
Reference Voltage	Over Temperature (Note 7)	1.19		1.27	1.185		1.285	V
Feedback Pin Bias Current			40	60		40	60	nA
Reference Voltage Temperature Coefficient	(Note 12)		20				50	$\text{ppm}/^\circ\text{C}$
Feedback Pin Bias Current Temperature Coefficient			0.1				0.1	$\text{nA}/^\circ\text{C}$
Error Comparator								
Output Leakage Current	$V_{\text{OH}} = 30\text{V}$		0.01	1		0.01	1	μA
Output Low Voltage	$V_{\text{in}} = 4.5\text{V}$ $I_{\text{OL}} = 400\mu\text{A}$		150	250		150	250	mV
Upper Threshold Voltage	(Note 6)	40	60		40	60		mV
Lower Threshold Voltage	(Note 6)		75	95		75	95	mV
Hysteresis	(Note 6)		15			15		mV
Shutdown Input								
Input logic Voltage	Low (Regulator ON)		1.3	0.7		1.3	0.7	V
	High (Regulator OFF)	2			2			V
Shutdown Pin Input Current (Note 3)	$V_s = 2.4\text{V}$		30	50		30	50	μA
	$V_s = 30\text{V}$		450	600		450	600	μA
Regulator Output Current in Shutdown (Note 3)	(Note 11)		3	10		3	10	μA

Note 1: Absolute Maximum Ratings are limits beyond which damage to the device may occur. Operating Ratings are conditions under which operation of the device is guaranteed. Operating Ratings do not imply guaranteed performance limits. For guaranteed performance limits and associated test conditions, see the Electrical Characteristics tables.

Note 2: Unless otherwise specified all limits guaranteed for $V_{\text{IN}} = (V_{\text{ONOM}} + 1)\text{V}$, $I_L = 100\mu\text{A}$ and $C_L = 1\mu\text{F}$ for 5V versions and 2.2 μF for 3V and 3.3V versions. Limits appearing in **boldface** type apply over the entire junction temperature range for operation. Limits appearing in normal type apply for $T_A = T_J = 25^\circ\text{C}$. Additional conditions for the 8-pin versions are FEEDBACK tied to V_{TAP} , OUTPUT tied to SENSE and $V_{\text{SHUTDOWN}} \leq 0.8\text{V}$.

Note 3: Guaranteed and 100% production tested.

Note 4: Guaranteed but not 100% production tested. These limits are not used to calculate outgoing AQL levels.

Note 5: Dropout voltage is defined as the input to output differential at which the output voltage drops 100 mV below its nominal value measured at 1V differential. At very low values of programmed output voltage, the minimum input supply voltage of 2V (2.3V over temperature) must be taken into account.

Note 6: Comparator thresholds are expressed in terms of a voltage differential at the feedback terminal below the nominal reference voltage measured at $V_{\text{IN}} = (V_{\text{ONOM}} + 1)\text{V}$. To express these thresholds in terms of output voltage change, multiply by the error amplifier gain = $V_{\text{out}}/V_{\text{ref}} = (R1 + R2)/R2$. For example, at a programmed output voltage of 5V, the error output is guaranteed to go low when the output drops by 95 mV x 5V/1.235 = 384 mV. Thresholds remain constant as a percent of V_{out} as V_{out} is varied, with the dropout warning occurring at typically 5% below nominal, 7.5% guaranteed.

Note 7: $V_{\text{ref}} \leq V_{\text{out}} \leq (V_{\text{in}} - 1\text{V})$, $2.3 \leq V_{\text{in}} \leq 30\text{V}$, $100\mu\text{A} \leq I_L \leq 150\text{mA}$, $T_J \leq T_{\text{JMAX}}$.

Note 8: The junction-to-ambient thermal resistance are as follows: 180°C/W and 160°C/W for the TO-92 (N) package with 0.40 inch and 0.25 inch leads to the printed circuit board (PCB) respectively, 105°C/W for the molded plastic DIP (P) and 160°C/W for the molded plastic SO-8 (S). The above thermal resistances for the N, S and P packages apply when the package is soldered directly to the PCB.

Note 9: May exceed input supply voltage.

Note 10: When used in dual-supply systems where the output terminal sees loads returned to a negative supply, the output voltage should be diode-clamped to ground.

Note 11: $V_{\text{shutdown}} \geq 2V$, $V_{\text{in}} \leq 30V$, $V_{\text{out}} = 0$, Feedback pin tied to $5V_{\text{TAP}}$.

Note 12: Output or reference voltage temperature coefficients defined as the worst case voltage change divided by the total temperature range.

Note 13: Thermal regulation is defined as the change in output voltage at a time T after a change in power dissipation is applied, excluding load or line regulation effects. Specifications are for a 50mA load pulse at $V_{\text{IN}} = 30V$ (1.25W pulse) for T = 10 ms.

Note 14: Regulation is measured at constant junction temperature, using pulse testing with a low duty cycle. Changes in output voltage due to heating effects are covered under the specification for thermal regulation.

Note 15: Line regulation for the AMS2951 is tested at 150°C for $I_L = 1 \text{ mA}$. For $I_L = 100 \mu\text{A}$ and $T_J = 125^\circ\text{C}$, line regulation is guaranteed by design to 0.2%. See typical performance characteristics for line regulation versus temperature and load current.

Note 16: All AMS2950 devices have the nominal output voltage coded as the last two digits of the part number. In the AMS2951 products, the 2.5V 3.0V and 3.3V versions are designated by the last two digits, but the 5V version is denoted with no code of the part number.

BLOCK DIAGRAM AND TYPICAL APPLICATIONS

AMS2950-XX

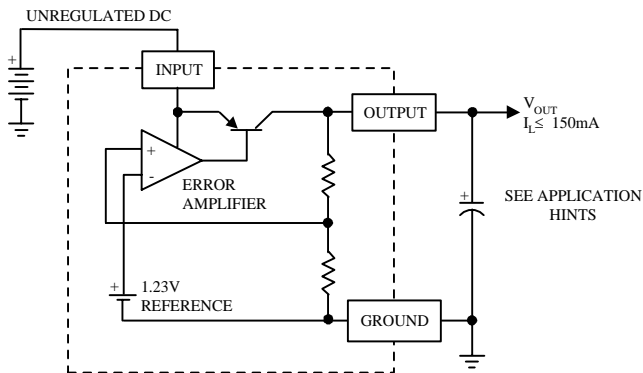

AMS2951-XX

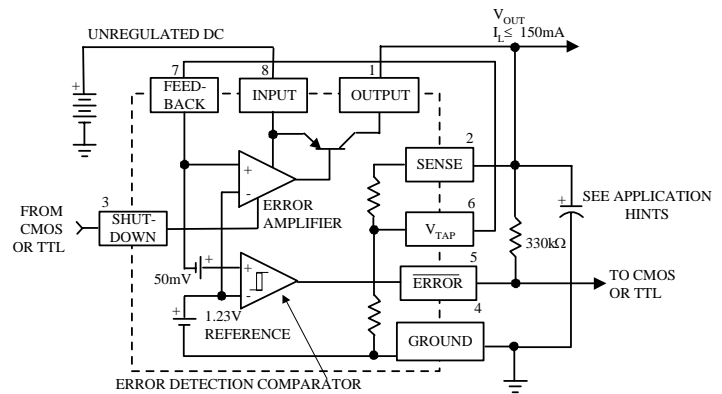

TYPICAL PERFORMANCE CHARACTERISTICS

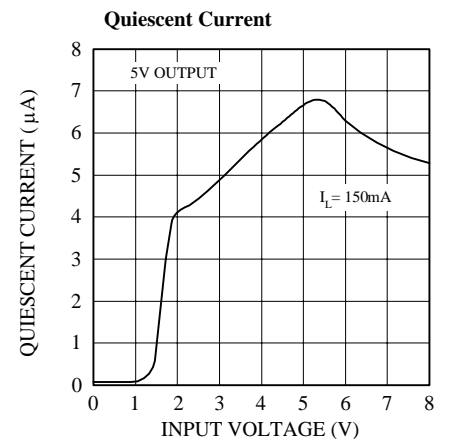
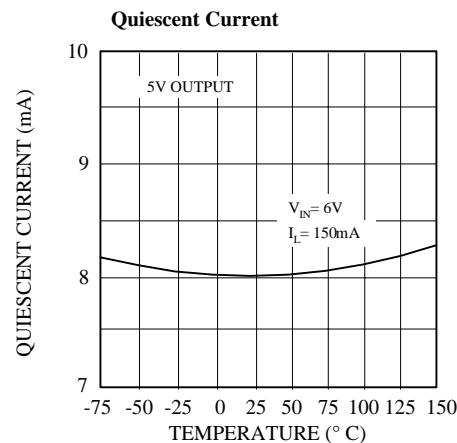
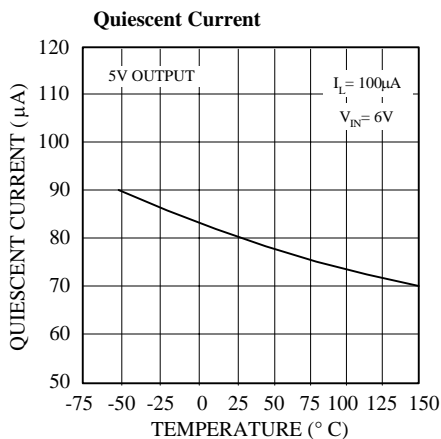
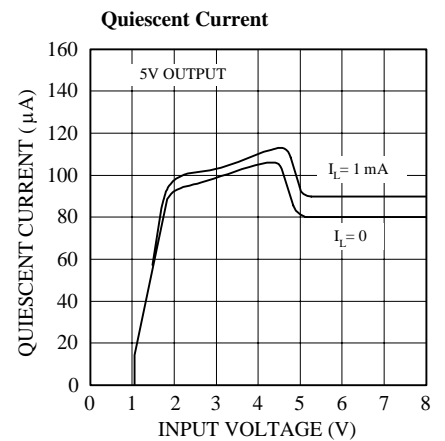
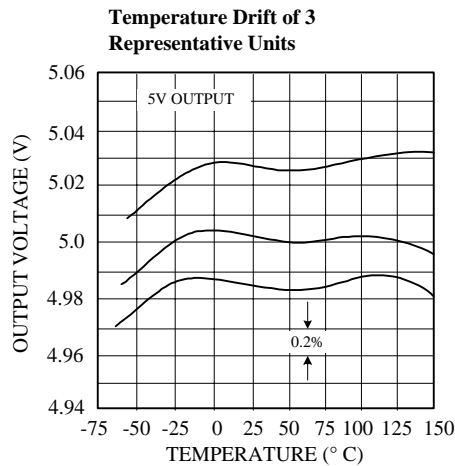
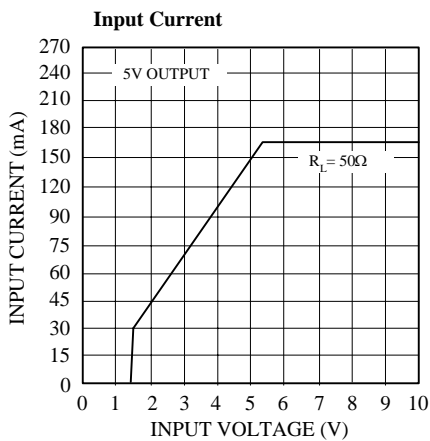
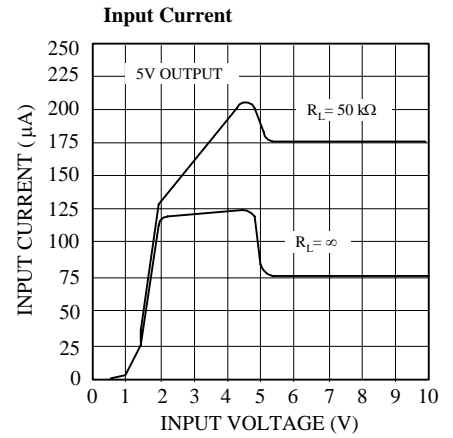
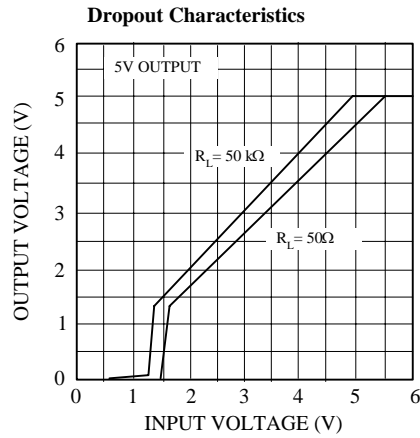
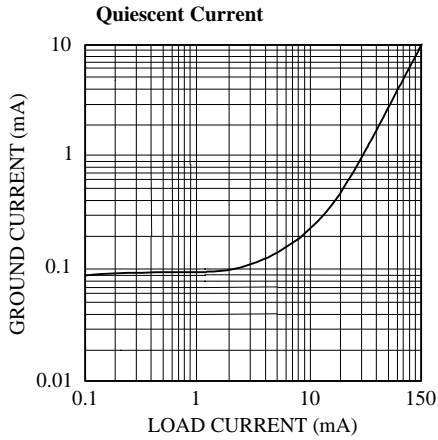

AMS2950/AMS2951

TYPICAL PERFORMANCE CHARACTERISTICS (Continued)

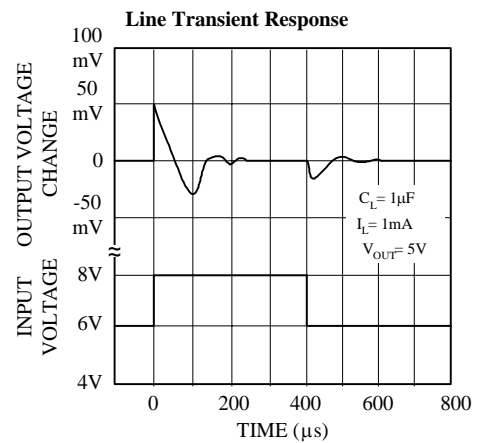
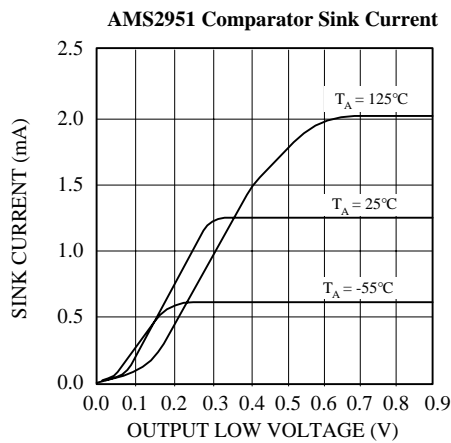
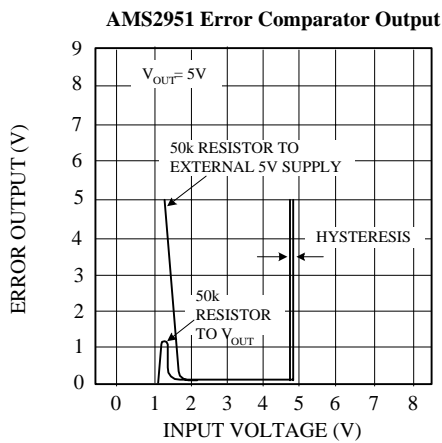
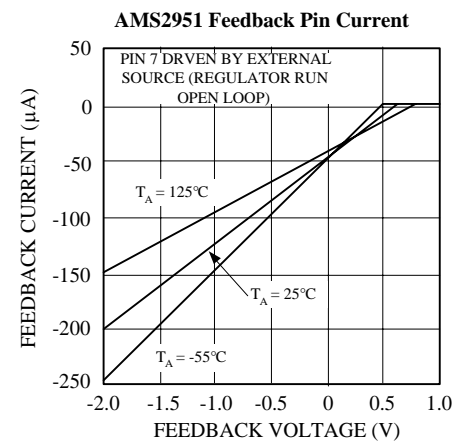
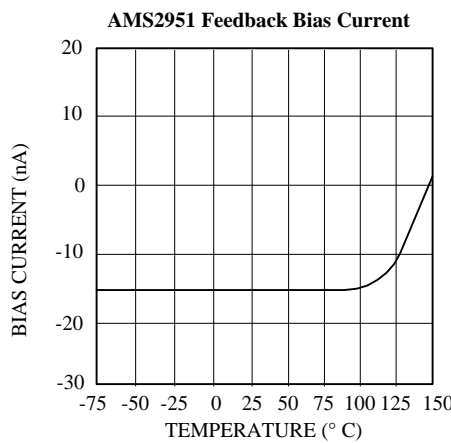
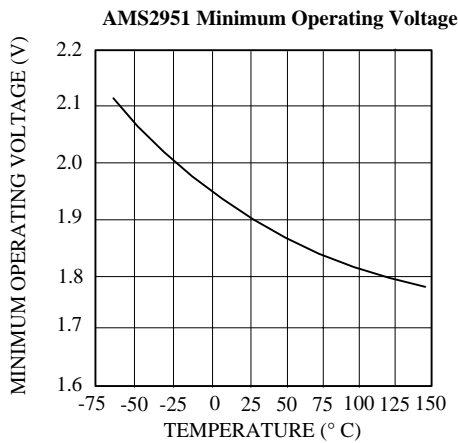
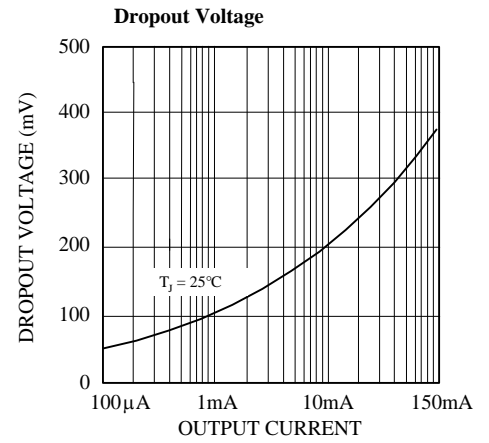
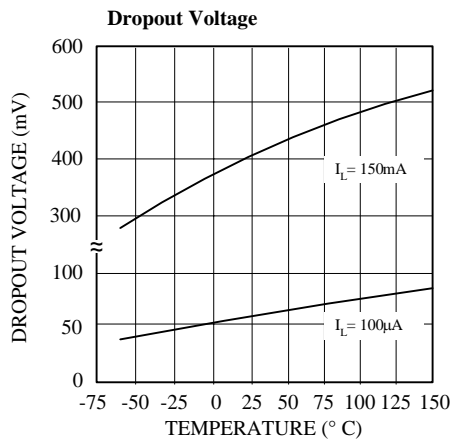
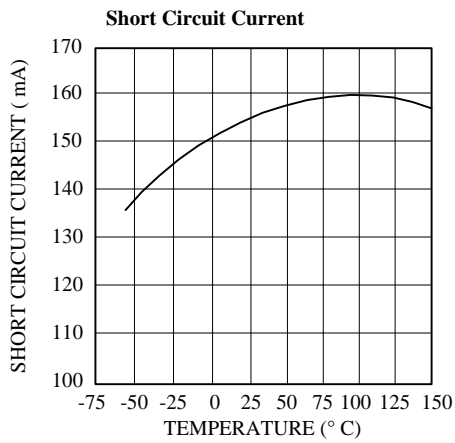

TYPICAL PERFORMANCE CHARACTERISTICS (Continued)

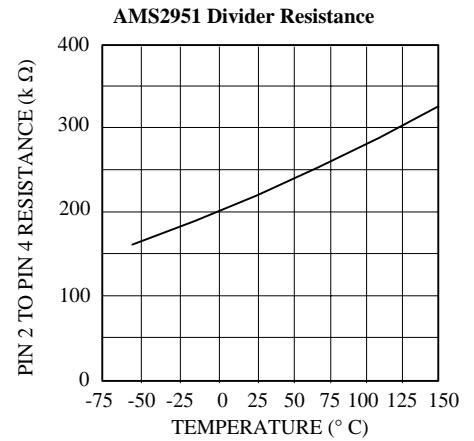
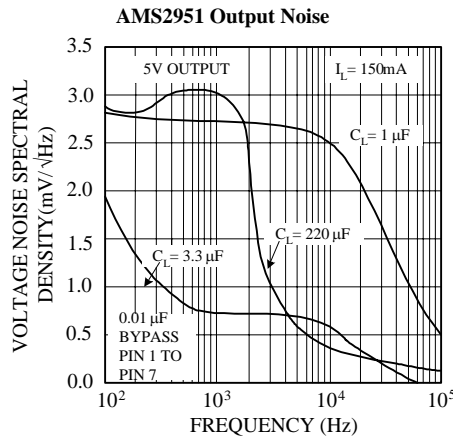
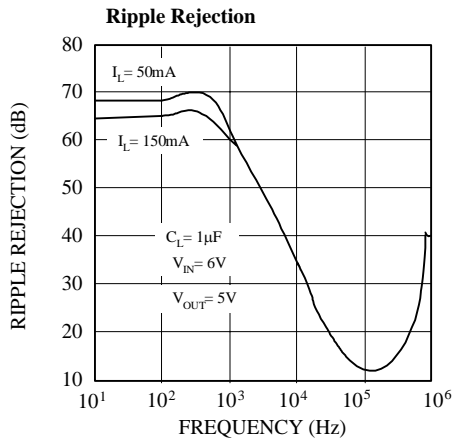
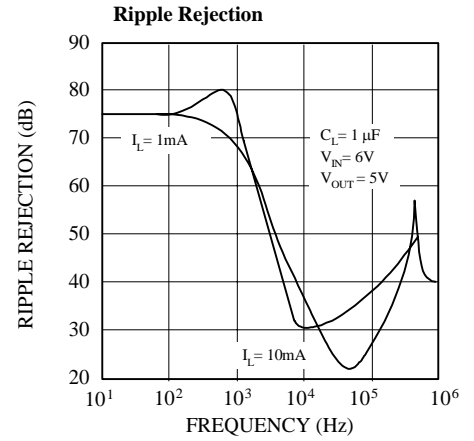
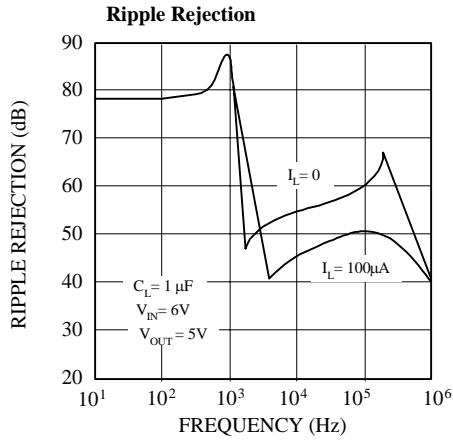
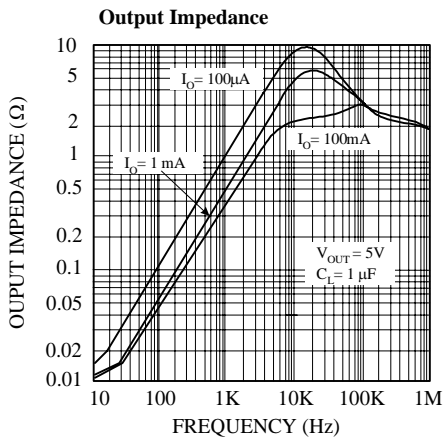
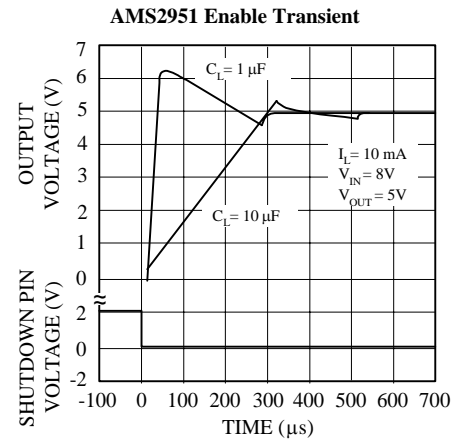
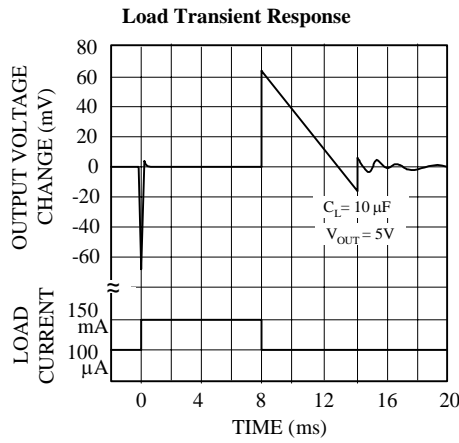
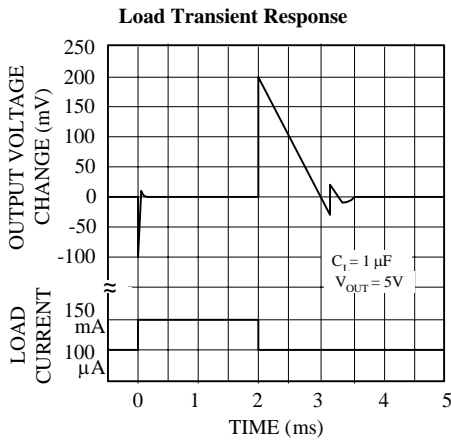

TYPICAL PERFORMANCE CHARACTERISTICS (Continued)

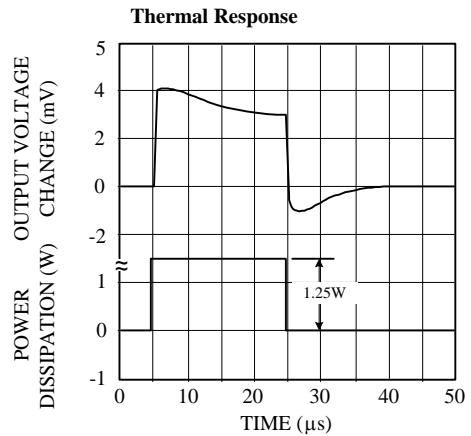
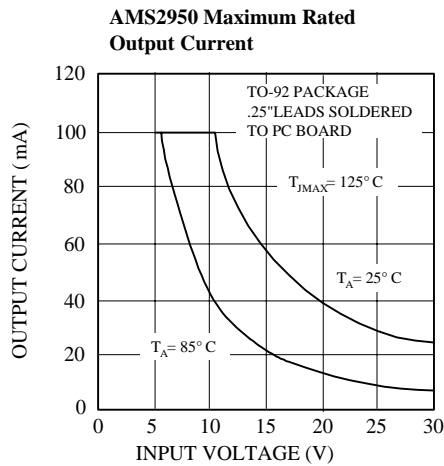
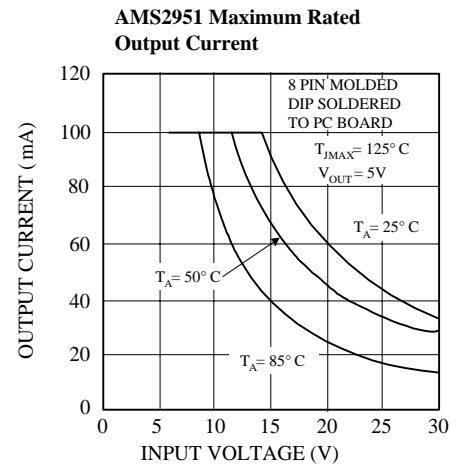
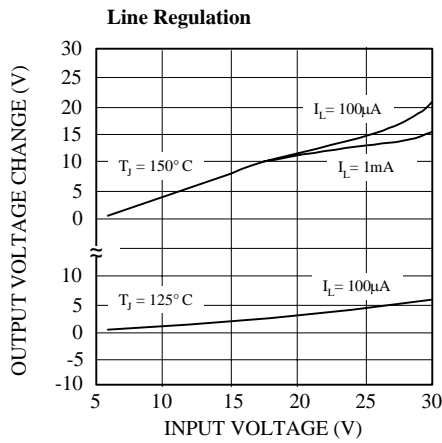
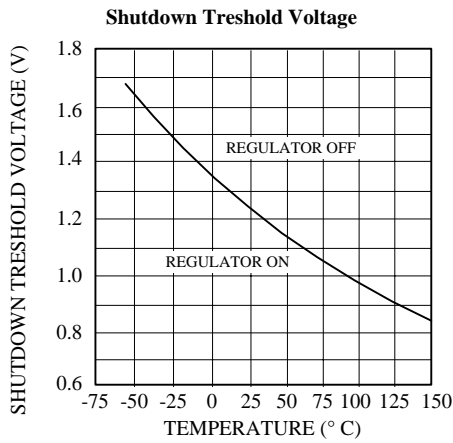

APPLICATION HINTS

External Capacitors

A 1.0 μF or greater capacitor is required between output and ground for stability at output voltages of 5V or more. At lower output voltages, more capacitance is required (2.2 μ or more is recommended for 3V and 3.3V versions). Without this capacitor the part will oscillate. Most types of tantalum or aluminum electrolytic works fine here; even film types work but are not recommended for reasons of cost. Many aluminum types have electrolytes that freeze at about -30°C , so solid tantalums are recommended for operation below -25°C . The important parameters of the capacitor are an ESR of about $5\ \Omega$ or less and resonant frequency above 500 kHz parameters in the value of the capacitor. The value of this capacitor may be increased without limit.

At lower values of output current, less output capacitance is required for stability. The capacitor can be reduced to 0.33 μF for currents below 10 mA or 0.1 μF for currents below 1 mA. Using the adjustable versions at voltages below 5V runs the error amplifier at lower gains so that more output capacitance is needed. For the worst-case situation of a 200mA load at 1.23V output (Output shorted to Feedback) a 3.3 μF (or greater) capacitor should be used.

Unlike many other regulators, the AMS2950, will remain stable and in regulation with no load in addition to the internal voltage divider. This is especially important in CMOS RAM keep-alive applications. When setting the output voltage of the AMS2951 version with external resistors, a minimum load of 1 μA is recommended.

A 1 μF tantalum or aluminum electrolytic capacitor should be placed from the AMS2950/AMS2951 input to the ground if there is more than 10 inches of wire between the input and the AC filter capacitor or if a battery is used as the input.

Stray capacitance to the AMS2951 Feedback terminal can cause instability. This may especially be a problem when using a higher value of external resistors to set the output voltage. Adding a 100 pF capacitor between Output and Feedback and increasing the output capacitor to at least 3.3 μF will fix this problem.

Error Detection Comparator Output

The comparator produces a logic low output whenever the AMS2951 output falls out of regulation by more than approximately 5%. This figure is the comparator's built-in offset of about 60 mV divided by the 1.235 reference voltage (Refer to the block diagram). This trip level remains "5% below normal" regardless of the programmed output voltage of the 2951. For example, the error flag trip level is typically 4.75V for a 5V output or 11.4V for a 12V output. The out of regulation condition may be due either to low input voltage, current limiting, or thermal limiting.

Figure 1 gives a timing diagram depicting the ERROR signal and the regulator output voltage as the AMS2951 input is ramped up and down. For 5V versions the ERROR signal becomes valid (low) at about 1.3V input. It goes high at about 5V input (the input voltage at which $V_{\text{out}} = 4.75$).

Since the AMS2951's dropout voltage is load dependent (see curve in typical performance characteristics), the input voltage trip point (about 5V) will vary with the load current. The output voltage trip point (approx. 4.75V) does not vary with load.

The error comparator has an open-collector output which requires an external pull-up resistor. This resistor may be returned to the output or some other supply voltage depending on system requirements. In determining a value for this resistor, note that the output is rated to sink 400 μA , this sink current adds to battery drain in a low battery condition. Suggested values range from 100K to 1M Ω . The resistor is not required if this output is unused.

Programming the Output Voltage (AMS2951)

The AMS2951 may be pin-strapped for the nominal fixed output voltage using its internal voltage divider by tying the output and sense pins together, and also tying the feedback and V_{TAP} pins together. Alternatively, it may be programmed for any output voltage between its 1.235V reference and its 30V maximum rating. As seen in Figure 2, an external pair of resistors is required.

The complete equation for the output voltage is:

$$V_{\text{out}} = V_{\text{REF}} \times (1 + R_1/R_2) + I_{\text{FB}}R_1$$

where V_{REF} is the nominal 1.235 reference voltage and I_{FB} is the feedback pin bias current, nominally -20 nA. The minimum recommended load current of 1 μA forces an upper limit of 1.2 M Ω on value of R_2 , if the regulator must work with no load (a condition often found in CMOS in standby) I_{FB} will produce a 2% typical error in V_{OUT} which may be eliminated at room temperature by trimming R_1 . For better accuracy, choosing $R_2 = 100\text{k}$ reduces this error to 0.17% while increasing the resistor program current by 12 μA . Since the AMS2951 typically draws 60 μA at no load with Pin 2 open-circuited, this is a small price to pay.

Reducing Output Noise

In reference applications it may be an advantageous to reduce the AC noise present at the output. One method is to reduce the regulator bandwidth by increasing the size of the output capacitor. This is the only way that noise can be reduced on the 3 lead AMS2950 but is relatively inefficient, as increasing the capacitor from 1 μF to 220 μF only decreases the noise from 430 μV to 160 μV rms for a 100 kHz bandwidth at 5V output.

Noise could also be reduced fourfold by a bypass capacitor across R_1 , since it reduces the high frequency gain from 4 to unity. Pick

$$C_{\text{BYPASS}} \cong 1 / 2\pi R_1 \times 200 \text{ Hz}$$

or about 0.01 μF . When doing this, the output capacitor must be increased to 3.3 μF to maintain stability. These changes reduce the output noise from 430 μV to 100 μV rms for a 100 kHz bandwidth at 5V output. With the bypass capacitor added, noise no longer scales with output voltage so that improvements are more dramatic at higher output voltages.

APPLICATION HINTS (Continued)

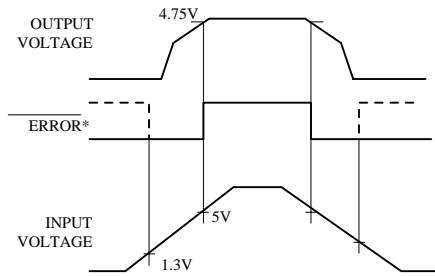

FIGURE 1. ERROR Output Timing

*When $V_{IN} \leq 1.3V$ the error flag pin becomes a high impedance, and the error flag voltage rises to its pull-up voltage. Using V_{out} as the pull-up voltage (see Figure 2), rather than an external 5V source, will keep the error flag voltage under 1.2V (typ.) in this condition. The user may wish to drive down the error flag voltage using equal value resistors (10 k Ω suggested), to ensure a low-level logic signal during any fault condition, while still allowing a valid high logic level during normal operation.

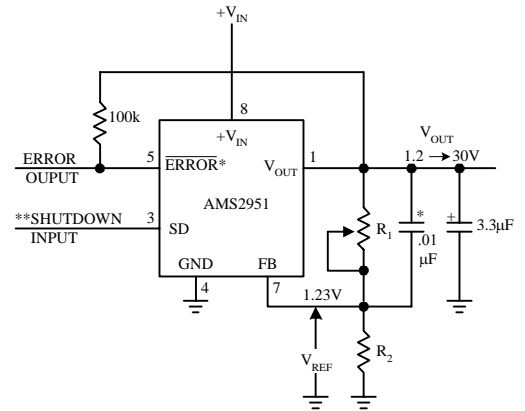

FIGURE 2. Adjustable Regulator

*See Application Hints.

$$V_{out} = V_{REF} \times (1 + R_1/R_2)$$

**Drive with TTL- high to shut down. Ground or leave if shutdown feature is not used.

Note: Pins 2 and 6 are left open.

TYPICAL APPLICATIONS

300 mA Regulator with 0.75 Dropout

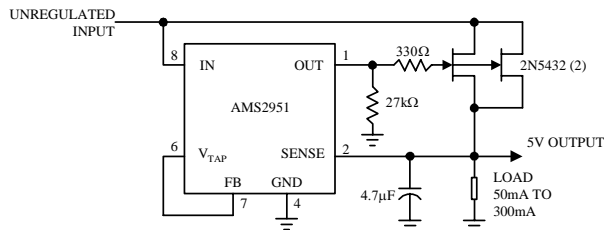

Wide Input Voltage Range Current Limiter

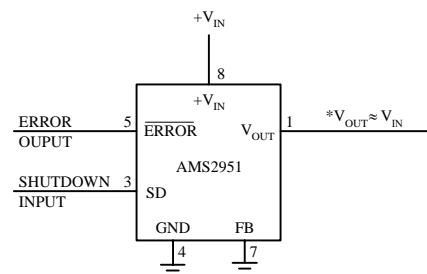

*Minimum Input-Output voltage ranges from 40mV to 400mV, depending on load current. Current limit is typically 160 mA

TYPICAL APPLICATIONS (Continued)

Low Drift Current Source

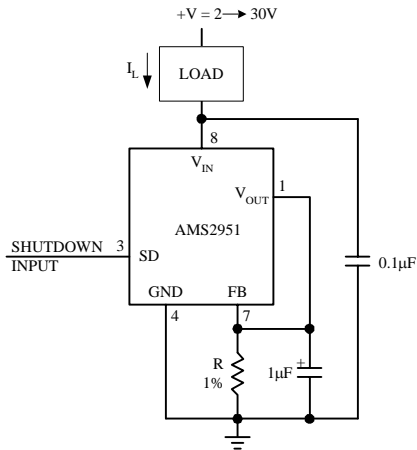

5Volt Current Limiter

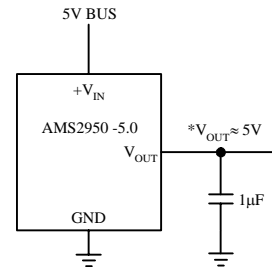

*Minimum Input-Output voltage ranges from 40mV to 400mV, depending on load current. Current limit is typically 160 mA

5V Regulator with 2.5V Sleep Function

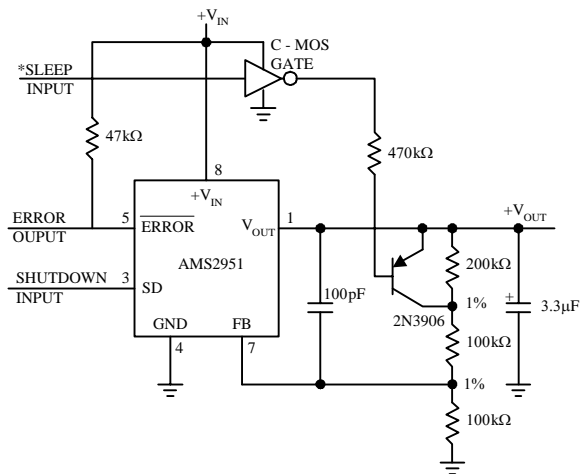

Open Circuit Detector for 4 to 20mA Current Loop

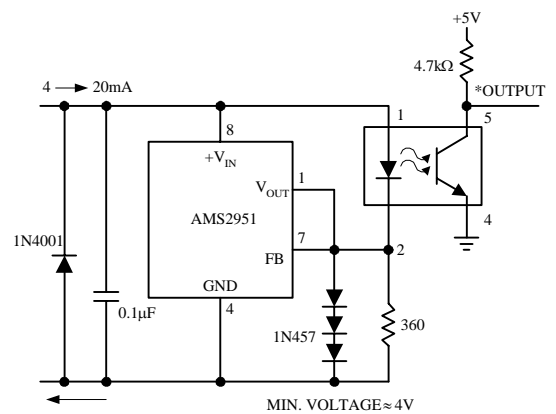

TYPICAL APPLICATIONS (Continued)

2 Ampere Low Dropout Regulator

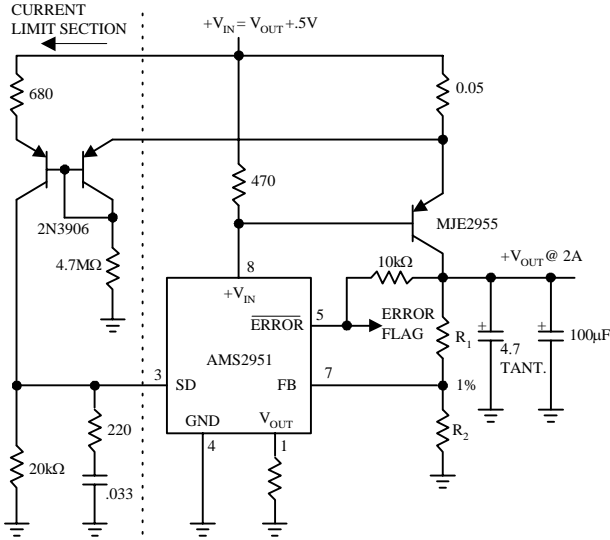

$$V_{OUT} = 1.23V(1+R1/R2)$$

For 5V V_{OUT} , use internal resistors. Wire pin 6 to 7 and pin 2 to $+V_{OUT}$ Buss.

Regulator with Early Warning and Auxiliary Output

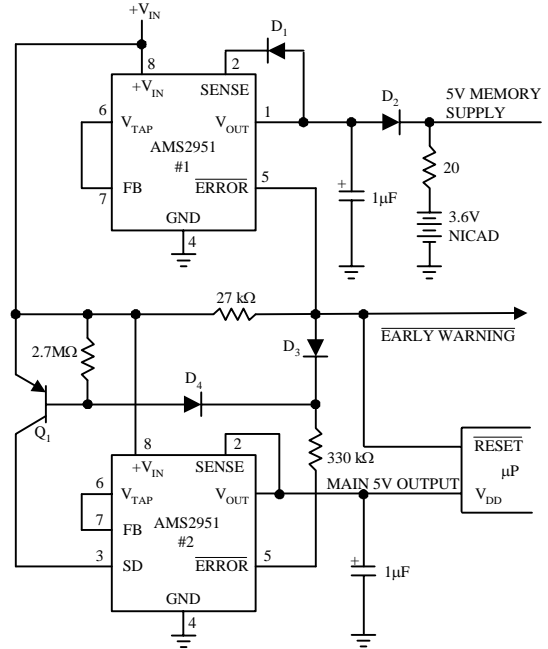

- Early warning flag on low input voltage
 - Main output latches off at lower input voltages
 - Battery backup on auxiliary output
- Operation: Reg.#1's V_{OUT} is programmed one diode drop above 5V. It's error flag becomes active when $V_{IN} \leq 5.7V$. When V_{IN} drops below 5.3V, the error flag of Reg.#2 becomes active and via Q1 latches the main output off. When V_{IN} again exceeds 5.7V Reg.#1 is back in regulation and the early warning signal rises, unlatching Reg.#2 via D3.

1A Regulator with 1.2V Dropout

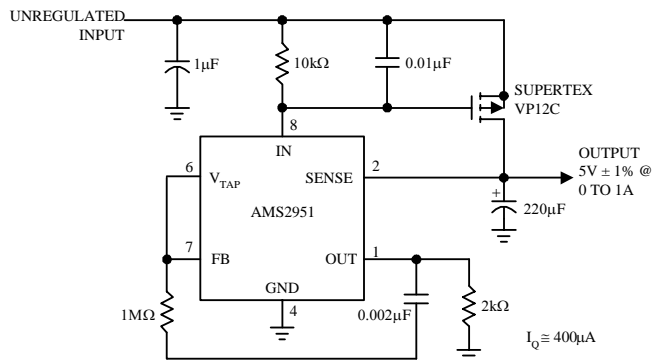

Latch Off When Error Flag Occurs

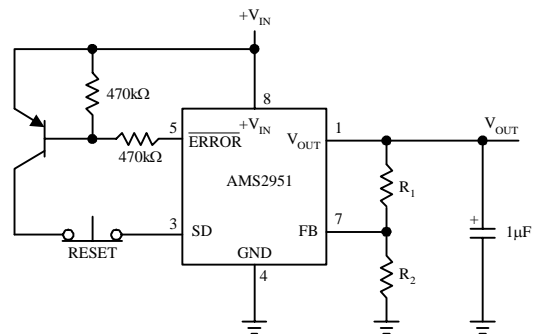

PACKAGE DIMENSIONS inches (millimeters) unless otherwise noted.

3 LEAD TO-92 PLASTIC PACKAGE (N)

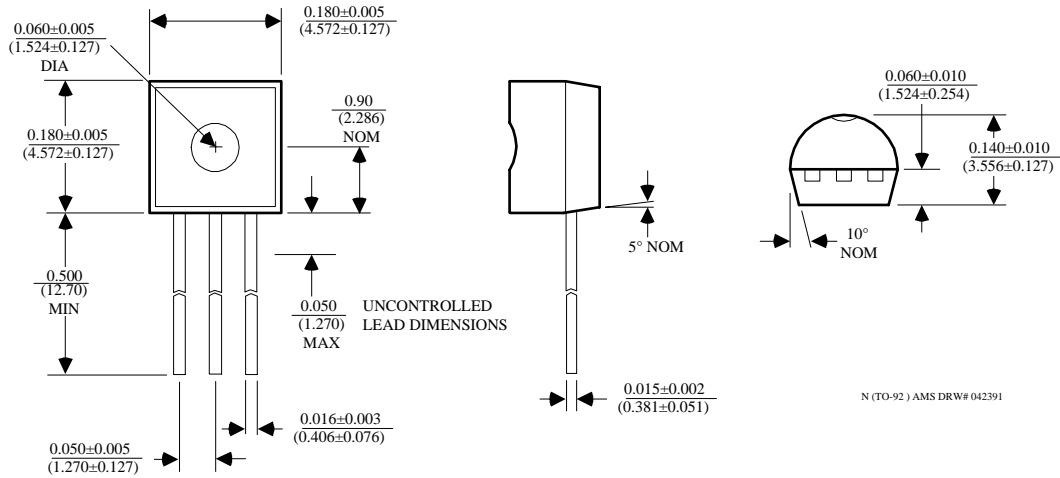

8 LEAD SOIC PLASTIC PACKAGE (S)

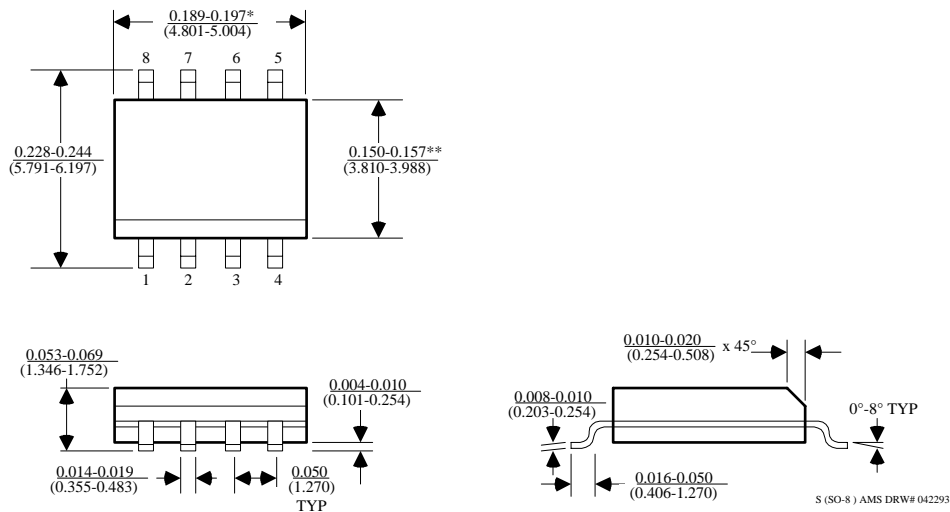

PACKAGE DIMENSIONS inches (millimeters) unless otherwise noted (Continued).

8 LEAD PLASTIC DIP PACKAGE (P)

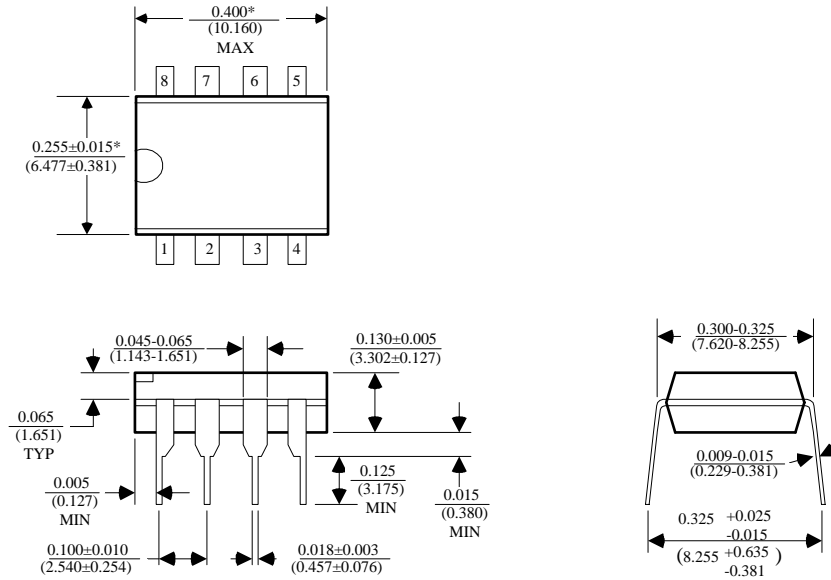

*DIMENSIONS DO NOT INCLUDE MOLD FLASH OR PROTUSIONS.
MOLD FLASH OR PROTUSIONS SHALL NOT EXCEED 0.010" (0.254mm)

P (8L, PDIP) AMS DRW# 042294