

FEATURES

- Guaranteed 2.7V to 15V supplies
- Open Collector Output
- Industrial temperature range: -40°C to +85°C
- Low Offset Voltage <5mV
- Low Supply Current: 7µA

APPLICATIONS

- Mobile battery operated products
- Notebooks and PDA's
- Alarmed Circuits
- LED driver
- Communication Circuits

GENERAL DESCRIPTION

The AMS303 has rail-to-rail output swing and input common-mode voltage. It exhibits excellent speed-power ratio, achieving a Propagation Delay of 400ns with low supply current.

The AMS303 is available in space saving 5-Pin SOT23. The small package saves space on pc boards, and enables the design of small portable electronic devices. It also allows the designer to place the device closer to the signal source to reduce noise pickup and increase signal integrity.

ORDERING INFORMATION:

MAX. OFFSET	PACKAGE TYPE	OPERATING TEMP. RANGE
	5 LEAD SOT-23	
5mV	AMS303AM1	-40 to +85°C
15mV	AMS303M1	-40 to +85°C

PIN CONNECTIONS

5L SOT-23 (M1)

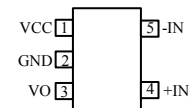

Top View

TYPICAL APPLICATION

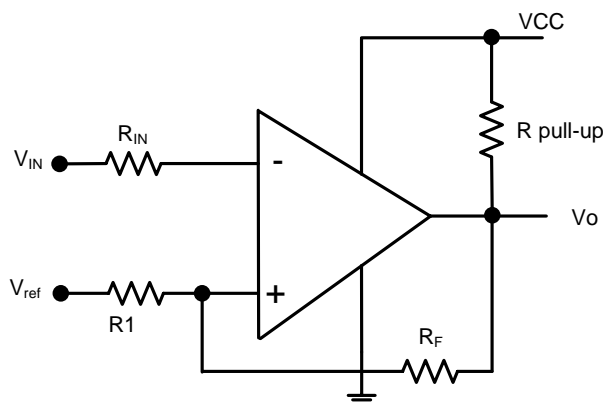

ABSOLUTE MAXIMUM RATINGS (Note 1)

Supply Voltage	2.7V to 16V	Temperature Range (Note 5)	-40°C to +85°C
Differential Input Voltage	±Supply Voltage	Storage Temp. Range	-65°C to 150°C
ESD Tolerance (Note 2)	2000V	Junction Temperature (Note 5)	150°C
Infrared or Convection (20 sec)	235°C	Thermal Resistance (Note 10)	265°C

2.7V ELECTRICAL CHARACTERISTICS

Electrical Characteristics at $T_A = 25^\circ\text{C}$, $V^+ = 2.7\text{V}$, $V^- = 0\text{V}$, $V_{CM} = V_O = V^+/2$ unless otherwise noted.

PARAMETER	CONDITIONS	AMS303			Units
		Min. (Note 7)	Typ. (Note 6)	Max. (Note 7)	
Input Offset Voltage			0.5	5	mV
Input Offset Voltage Average Drift			2		$\mu\text{V}/^\circ\text{C}$
Input Bias Current			11	20	nA
Input Offset Current			5	15	nA
A_v	Voltage Gain		100		dB
Common Mode Rejection Ratio	$0\text{V} \leq V_{CM} \leq 2.7\text{V}$		75		dB
Power Supply Rejection Ratio	$2.7\text{V} \leq V^+ \leq 10\text{V}$		80		dB
Input Common-Mode Voltage Range	For CMRR ≥ 55 dB	0	-0.2		V
			2.7	2.75	V
Output Low	$I_{load} = 2\text{mA}$		0.2	300	mV
Supply Current			7	10	μA

5.0V DC ELECTRICAL CHARACTERISTICS

Electrical Characteristics at $T_A = 25^\circ\text{C}$, $V^+ = 5.0\text{V}$, $V^- = 0\text{V}$, $V_{CM} = V_O = V^+/2$ unless otherwise noted.

PARAMETER	CONDITIONS	AMS303			Units
		Min. (Note 7)	Typ. (Note 6)	Max. (Note 7)	
Input Offset Voltage			0.5	5	mV
Input Offset Voltage Average Drift			2		$\mu\text{V}/^\circ\text{C}$
Input Bias Current			11	20	nA
Input Offset Current			5	15	nA
A_v	Voltage Gain		100		dB
Common Mode Rejection Ratio	$0\text{V} \leq V_{CM} \leq 5.0\text{V}$		75		dB
Power Supply Rejection Ratio	$5\text{V} \leq V^+ \leq 10\text{V}$		80		dB
Input Common-Mode Voltage Range	For CMRR ≥ 55 dB	0	-0.2		V
			2.7	2.75	V
Output Low	$I_{load} = 2\text{mA}$		0.2	300	mV
Supply Current			7	10	μA

15.0V DC ELECTRICAL CHARACTERISTICS

Electrical Characteristics at $T_A = 25^\circ\text{C}$, $V^+ = 15.0\text{V}$, $V^- = 0\text{V}$, $V_{\text{CM}} = V_O = V^+/2$ unless otherwise noted.

PARAMETER	CONDITIONS	AMS303			Units
		Min. (Note 7)	Typ. (Note 6)	Max. (Note 7)	
Input Offset Voltage			0.5	5	mV
Input Offset Voltage Average Drift			2		$\mu\text{V}/^\circ\text{C}$
Input Bias Current			11	20	nA
Input Offset Current			5	15	nA
A_v	Voltage Gain		100		dB
Common Mode Rejection Ratio	$0\text{V} \leq V_{\text{CM}} \leq 5.0\text{V}$		75		dB
Power Supply Rejection Ratio	$5\text{V} \leq V^+ \leq 10\text{V}$		80		dB
Input Common-Mode Voltage Range	For $\text{CMRR} \geq 55\text{ dB}$	0	-0.2 2.7	2.75	V V
Output Low	$I_{\text{load}} = 2\text{mA}$		0.2	300	mV
Supply Current			7	10	μA

AC ELECTRICAL CHARACTERISTICS

Unless otherwise specified, all limits guaranteed for $T_J = 25^\circ\text{C}$, $V^+ = 5\text{V}$, $V^- = 0\text{V}$, $V_{\text{CM}} = V_O = V^+/2$. Boldface limits apply at the temperature extreme.

PARAMETER	CONDITIONS	AMS303			Units
		Min.	Typ.	Max.	
Rise Time	$f = 10\text{kHz}$, $C_L = 50\text{ pF}$, (Note 9) Overdrive = 100 mV, 5Ω Pullup		25		ns
Fall Time	$f = 10\text{ kHz}$, $C_L = 50\text{ pF}$, (Note 9) Overdrive = 100mV, 5Ω Pullup		30		ns
Propagation Delay (High to Low) (Note 11)	$f = 10\text{ kHz}$, $C_L = 50\text{ pF}$, $5\text{ k}\Omega$ Pullup (Note 9)	10 mV overdrive 100 mV overdrive	400 320		ns ns
Propagation Delay (Low to High) (Note 11)	$f = 10\text{ kHz}$, $C_L = 50\text{ pF}$, $5\text{ k}\Omega$ Pullup (Note 9)	10 mV overdrive 100 mV overdrive	420		ns

Note 1: Absolute Maximum Ratings indicate limits beyond which damage to the device may occur. Operating Ratings indicate conditions for which the device is intended to be functional, but specific performance is not guaranteed. For guaranteed specifications and the test conditions, see the Electrical Characteristics.

Note 2: Human body model, $1.5\text{ k}\Omega$ in series with 100 pF .

Note 3: Applies to both single-supply and split-supply operation. Continuous short circuit operation at elevated ambient temperature can result in exceeding the maximum allowed junction temperature of 150°C . Output currents in excess of $\pm 30\text{ mA}$ may adversely affect reliability.

Note 4: The maximum power dissipation is a function of $T_{J(\text{max})}$, θ_{JA} , and T_A . The maximum allowable power dissipation at any ambient temperature is.

Note 5: $P_D = (T_{J(\text{max})} - T_A) / \theta_{JA}$. All numbers apply for packages soldered directly into a PC board.

Note 6: Typical values represent the most likely parametric norm.

Note 7: All limits are guaranteed by testing or statistical analysis.

Note 8: Limiting input pin current is only necessary for input voltages which exceed the absolute maximum input voltage rating.

Note 9: Do not short circuit the output to V^+ when V^+ is greater than 12V or reliability will be adversely affected.

Note 10: C_L includes the probe and test jig capacitance.

Note 11: Input offset voltage average drift is calculated by dividing the accelerated operating life V_{OS} drift by the equivalent operational time. This represents worst case input conditions and includes the first 30 days of drift.

TYPICAL PERFORMANCE CHARACTERISTICS

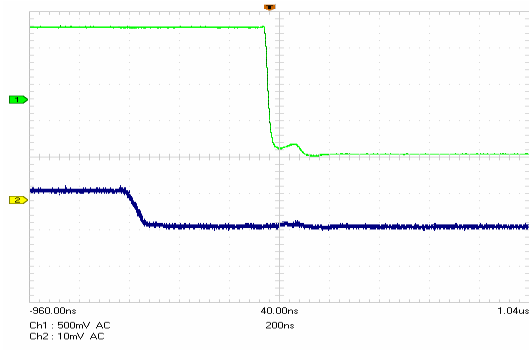

5mV input falling prop delay

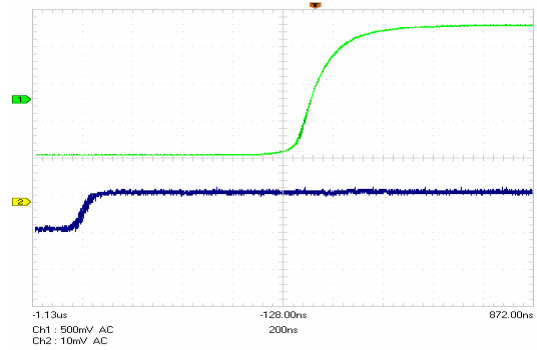

5mV input rising prop delay

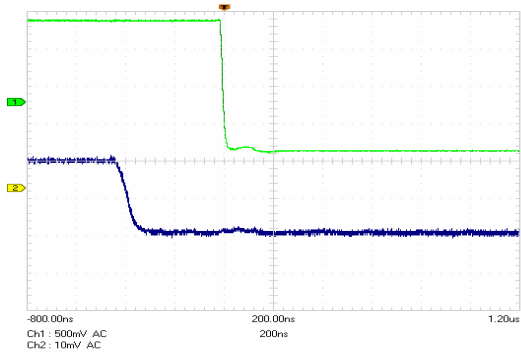

10mV input falling prop delay

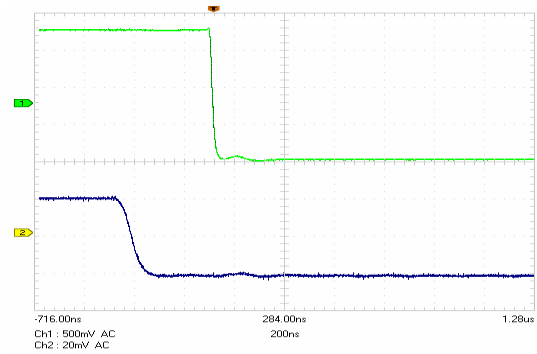

20mV input falling prop delay

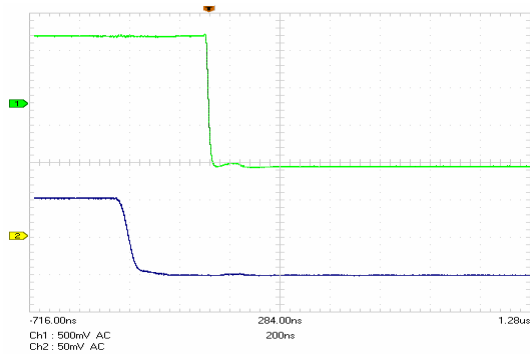

50mV input falling prop delay

TYPICAL PERFORMANCE CHARACTERISTICS

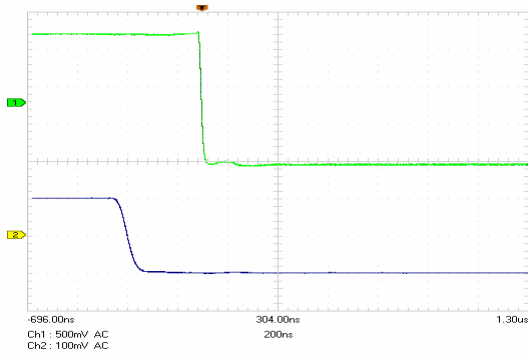

100mV input falling prop delay

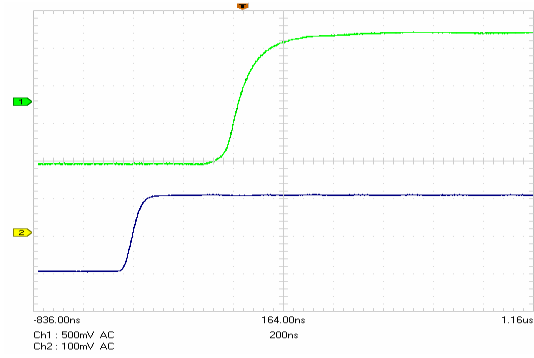

100mV input rising prop delay

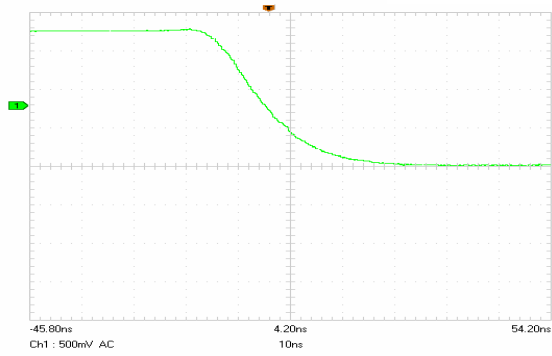

Fall time 100mV overdrive 1K 10pF load

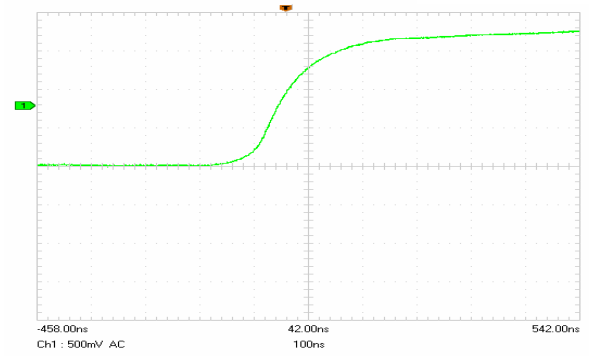

Rise time 100mV overdrive 1K 10pF load

APPLICATION INFORMATION

AMS303 is an open collector with a very low supply current of typical 7 μ A. The advantage of this product is the small space package and simplicity of application. It operates from as low as +2.7V to +15V and the output pull-up resistor could be biased from higher or lower voltage than Vcc. When a large input signal is applied, an input resistor should be used to limit the input current in case of excessive input voltage. If the input voltage is pulled above the supply voltage Vcc, a set of clamp diode should be used to protect the input circuit. Since AMS303 is a high impedance input, PCB layout precautions should be taken to avoid noise pick-up from adjacent circuits or electrically noisy environments. A good practice is to keep the input traces very short and input components very close to the package. If long conductors are necessary, shielded or twisted pairs should be used.

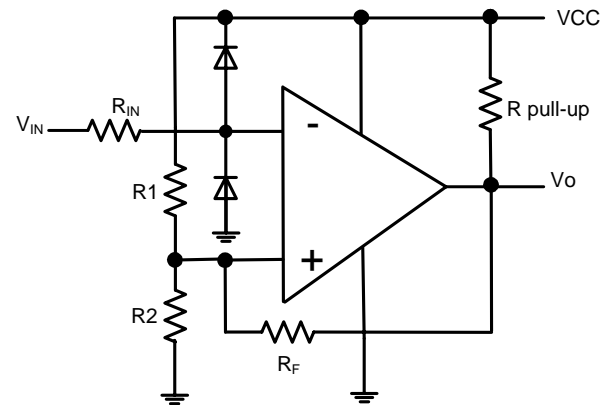

PACKAGE DIMENSIONS inches (millimeters) unless otherwise noted.

5 LEAD SOT-23 PLASTIC PACKAGE (M1)

