

FEATURES

- 2 Independent Asynchronous Buck Converters in SO-8
- Internally compensated
- Built in soft start
- Enable with Zero current shut down
- 400KHz switching per output
- Interleaved oscillator to reduced supply ripple
- Simply re-configures to 2 phase single output
- Up to 4A output in 2 phase mode
- Independent hiccup current limit

APPLICATIONS

- Audio Power Amplifiers
- Portable (Notebook) Computers
- Point of regulation for high performance electronics
- Consumer Electronics
- Desktop Computers
- LCD TVs and LCD monitors
- Distributed Power Systems
- Battery Chargers
- Pre-Regulator for Linear Regulators

GENERAL DESCRIPTION

AMS4122 is a dual switching regulator capable to deliver up to 2A for each channel. Internally Compensated internal Soft Start makes AMS4122 one of the simplest and easiest switching regulators to use with the minimum external components. Each regulator has independent hiccup current limit. The Enable pin turns both devices on when a voltage of 2.5V or higher it is applied to EN pin. Since both devices share one single package the thermal protection turns off both devices when the die temperature exceeds approximately 135°C. Both regulators are adjustable using a 0.600V reference for low output voltage settings. The oscillators are 180° phase to each other to reduce the ripples on the input power supply and minimize the power dissipation on the package. The device can be easily configured for Two Phase single output switching regulator capable of 5A output load. By applying a 2.5V or greater on feedback pin of the second switching regulator the device enters in Two Phase Mode. The first benefit of having a Two Phase device is reducing the output ripples by a factor of four as the single phase. The second benefit is higher output current capability at overall low cost. AMS4122 combined with AMS4123 (2A Switching Regulator + 1A LDO in SO-8) makes complete solution for LCD TV power requirements.

ORDERING INFORMATION

Package Type SOIC EDP	TEMP. RANGE
AMS4122S	-25°C to 125°C

TYPICAL APPLICATION

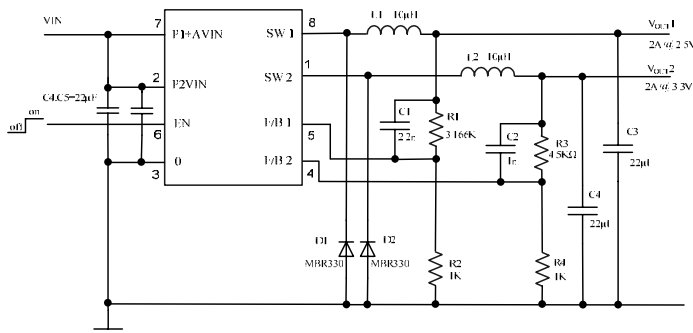

PIN CONNECTIONS

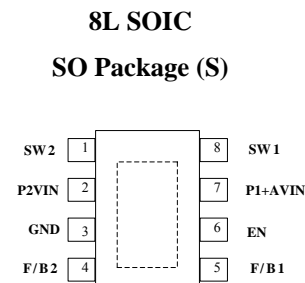

Top View

PIN DESCRIPTION

Pin Number	NAME	DESCRIPTION
1	SW2	This connects the inductor the Internal Switch2
2	P2VIN	Input Power Pin for SW2 from unregulated power supply
3	GND	Ground Pin connected to PCB ground plane. This pin is also the ground for internal voltage reference.
4	F/B2	Feedback2. A resistor network of two resistors is used to set-up the output voltage connected between Output2 to GND. The node between the two resistors is connected to Feedback2 pin. In Two Phase Mode F/B2 should be connected to a voltage 2.5V or higher
5	F/B1	Feedback1. A resistor network of two resistors is used to set-up the output voltage connected between Output1 to GND. The node between the two resistors is connected to Feedback1 pin.
6	EN	Enable. A voltage greater than 2.5V at this pin enables both devices operation.
7	P1+AVIN	Input Power Pin for SW1 and Analog Input Voltage that powers up the chip
8	SW1	This connects the inductor the Internal Switch1

RECOMMENDED OPERATING CONDITIONS: The minimum input voltage should be 4.5V, however the device will function as low as 4.0V. The maximum operating voltage should be 20V, the device will work at 22V but the switching loss is higher. The best performance is at 1.5A output load per channel; however it works well with 2A load per channel. The minimum supply voltage is $V_{out} + 1V$ for 1A load and $V_{out} + 1.1V$ for 2A load but must be higher than 4.2V. There is an internal UVLO that will turn off the device if the input voltage is below 4.0V. When the input voltage exceeds 12V the output load current should be maintain below 1.5A, due to switching loss the device will have lower performance.

ABSOLUTE MAXIMUM RATINGS

V _{IN}	4.0V to 20V	Junction Temperature	+150°C
F/B	-0.3 to +12.0V	Storage Temperature	-65°C to +150°C
EN	-0.3V to +20V	Lead temperature	260°C

ELECTRICAL CHARACTERISTICS

Electrical Characteristics at T_A= 25 °C and V_{IN}=12V (unless otherwise noted).

PARAMETER	TEST CONDITIONS	AMS4122			Units
		Min.	Typ.	Max.	
Feedback voltage	F/B-1 and F/B-2	0.590	0.6	0.610	V
Full Load Output Current	Measured on each channel (note 4)			2	A
Feedback2 (note 1)	Two Phase Mode		1.3	2.5	V
Phase Shift between Outputs	Dual Output Mode	171	180	189	<°
Current Limit	Per Output		4		A
Phase current match	Dual Phase Single Output Mode		10		%
Oscillator Frequency	Note(2)	360	400	440	KHz
Maximum Duty Cycle				100	%
Enable Threshold			2.5		V
Enable Hysteresis			120		mV
Enable Pull-up Current			0.7		μA
Under Voltage Lockout Threshold Rising			3.5		V
Under Voltage Lockout Threshold Hysteresis			150		mV
Supply Current (Shutdown)	V _{EN} ≤ 0.4V		100		nA
Supply Current (Quiescent)	V _{EN} ≥ 2.8V; V _{FB} = 1.5V		1.5	1.9	mA
Thermal Shutdown			135		°C
Total Power dissipation	Note (3)		2.5		W

Notes: 1) When a 1.3V or greater is applied to F/B2, the device enters in Two Phase Mode of operation.

2) The oscillators for each switching regulator are shifted by 180° of each-other to accommodate dual phase operation and reduce the ripples in the input power supply.

3) The power dissipation for SO-8 EDP package is limited to 2.5W rated at 25°C ambient temperatures. The thermal resistance Junction to Case is 45°C/W. Total power dissipation for both switching regulators should be taken in consideration when calculating the output current for each regulator.

4) The load current is specified for two output configuration. The output load it is dependent of the output voltage. The total output power should be kept under 6W/channel to avoid thermal shut-down.

TYPICAL PERFORMANCE WAVEFORM

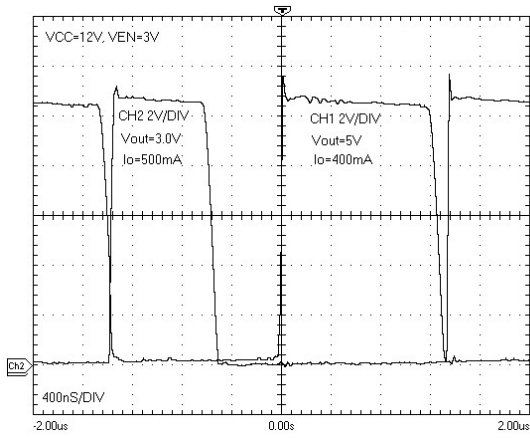

AMS4122 DUAL OUTPUT $V_{in}=12V$
Low Output Current

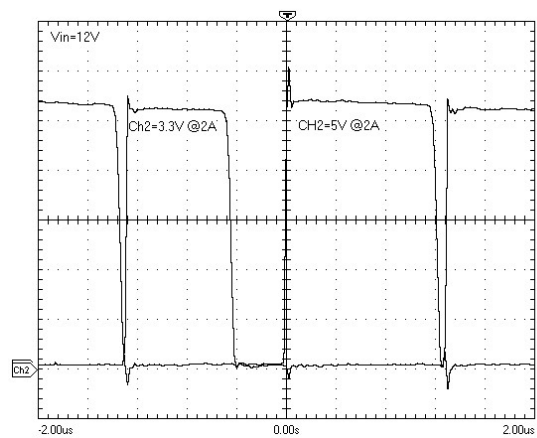

AMS4122 DUAL OUTPUT $V_{in}=12V$
Full Load Output Current

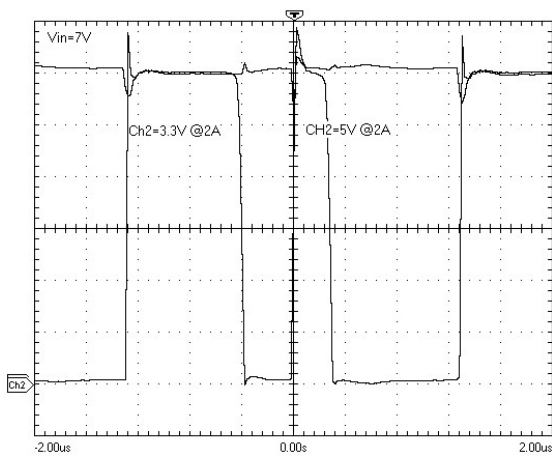

DUAL OUTPUT $V_{in}=7V$
Full Load Output Current

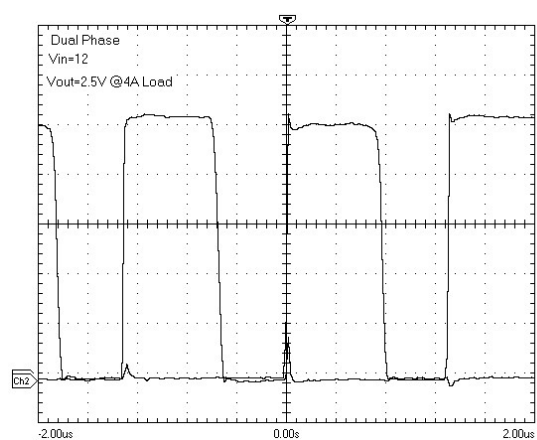

DUAL PHASE
Full Load Output Current

TYPICAL APPLICATION

2 Phase Single Output Application

$$V_{OUT} = V_{REF} (1 + R1/R2)$$

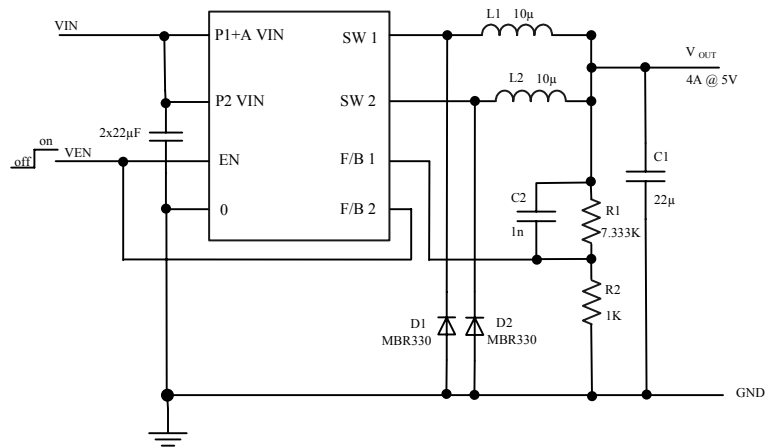

Dual Output Application

$$V_{OUT1} = V_{REF} (1 + R1/R2)$$

$$V_{OUT2} = V_{REF} (1 + R3/R4)$$

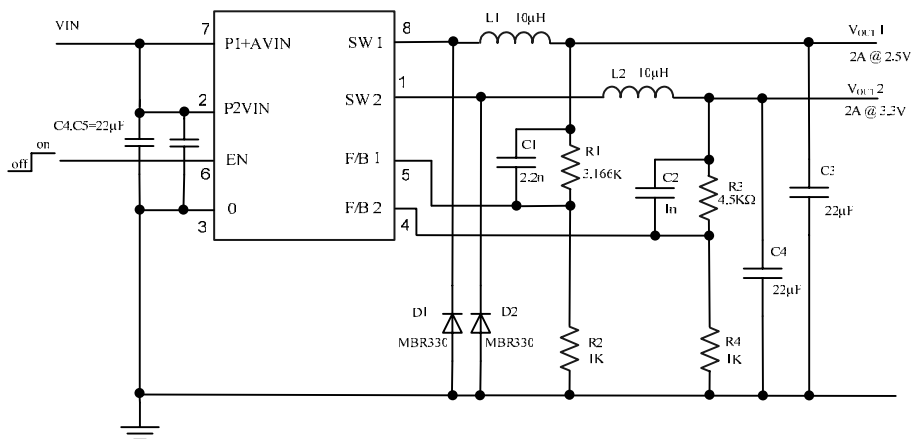

PACKAGE DIMENSIONS inches (millimeters) unless otherwise noted.

8 LEAD SOIC PLASTIC PACKAGE (S)

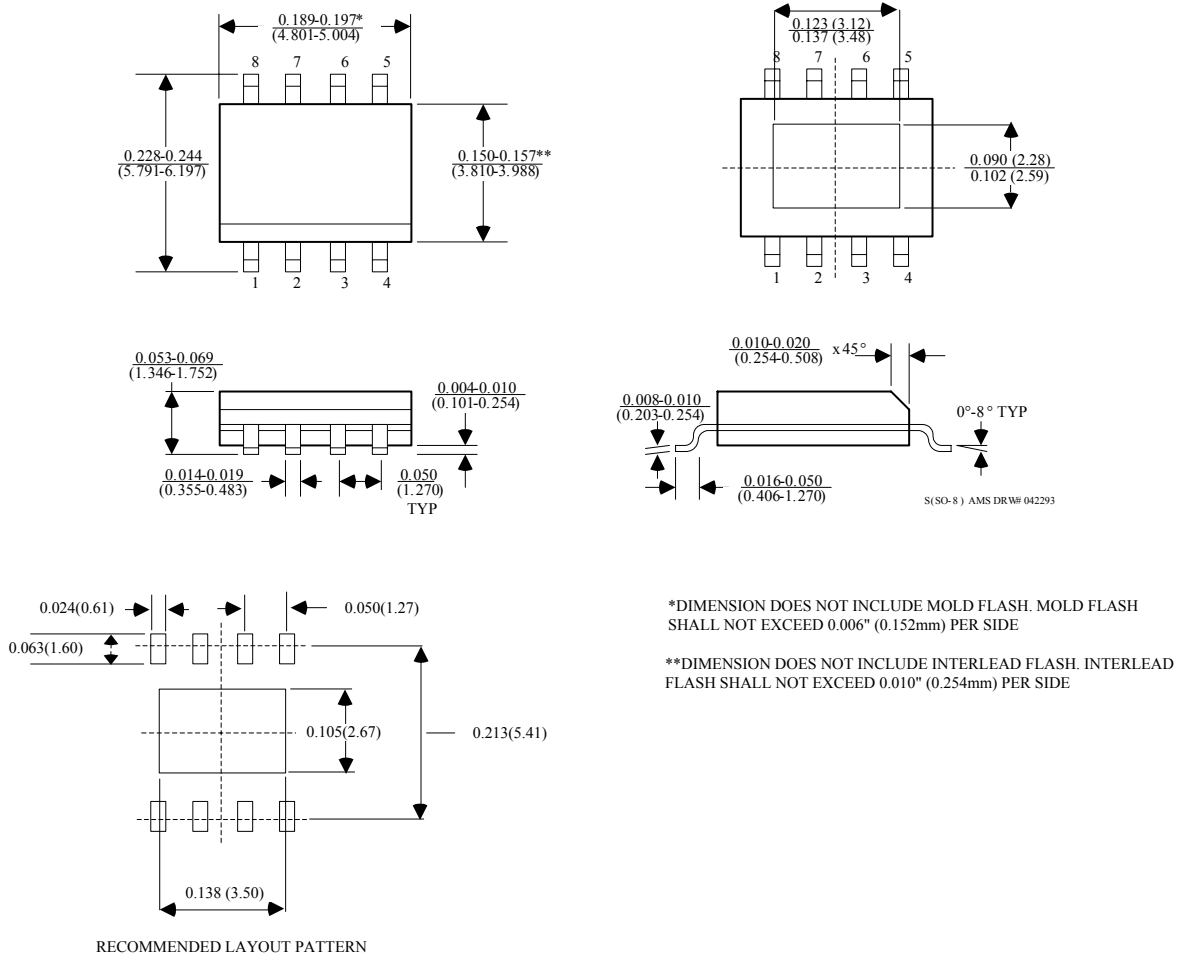

*DIMENSION DOES NOT INCLUDE MOLD FLASH. MOLD FLASH SHALL NOT EXCEED 0.006" (0.152mm) PER SIDE

**DIMENSION DOES NOT INCLUDE INTERLEAD FLASH. INTERLEAD FLASH SHALL NOT EXCEED 0.010" (0.254mm) PER SIDE

S(SO-8) AMS DRW 042293