

PIN MMIC HIGH ISOLATION SPDT SWITCH, 18 - 40 GHz

Typical Applications

The HMC971 is ideal for:

- Telecom Infrastructure
- Microwave Radio & VSAT
- Military Radios, Radar & ECM
- Space Systems
- Test Instrumentation

Features

- High Isolation: 40 dB
- Low Insertion Loss: 1.6 dB
- High Linearity: +43 dBm Input IP3
- High Power Handling: +34 dBm Input P1dB
- Die Size: 2.21 x 1.26 x 0.1 mm

Functional Diagram

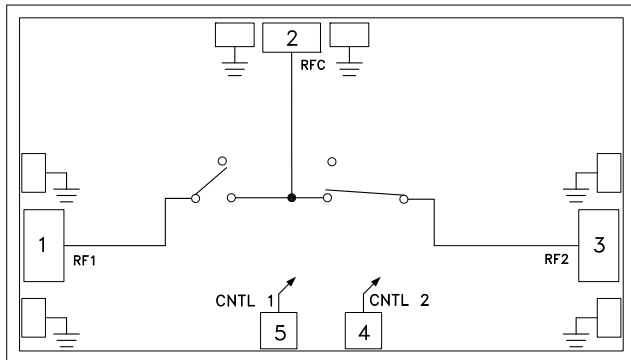

General Description

The HMC971 is a broadband high isolation PIN SPDT MMIC chip. Covering 18 to 40 GHz, the switch features >55 dB isolation at lower frequencies and >45 dB at higher frequencies. The switch operates using complementary negative control voltage logic lines of 0/-10V. All data is measured with the chip in a 50 Ohm test fixture connected via 0.025 mm (1 mil) diameter wire bonds of minimal length 0.31 mm (12 mils).

Electrical Specifications, $T_A = +25^\circ\text{C}$, With 0/-10V Control, 50 Ohm System

Parameter	Frequency	Min.	Typ.	Max.	Units
Insertion Loss RFC to RF1	18 - 28 GHz		1.0	1.3	dB
	28 - 32 GHz		1.3	1.7	dB
	32 - 40 GHz		1.5	1.9	dB
Insertion Loss RFC to RF2	18 - 28 GHz		1.0	1.3	dB
	28 - 32 GHz		1.3	1.7	dB
	32 - 40 GHz		1.5	1.9	dB
Isolation		34	40		dB
Return Loss	"On State"	18 - 30 GHz		17	dB
		30 - 40 GHz		12	dB
Input Power for 1 dB Compression			34		dBm
Input Third Order Intercept (Two-Tone Input Power= +7 dBm Each Tone, 1 MHz Tone Separation)			43		dBm

**PIN MMIC HIGH ISOLATION
SPDT SWITCH, 18 - 40 GHz**

Insertion Loss, RFC to RF1

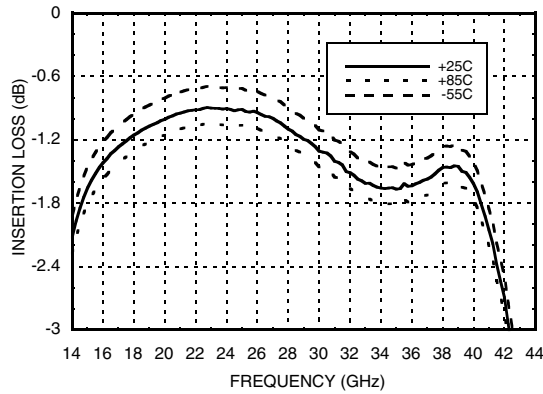

Isolation Loss, RFC to RF2

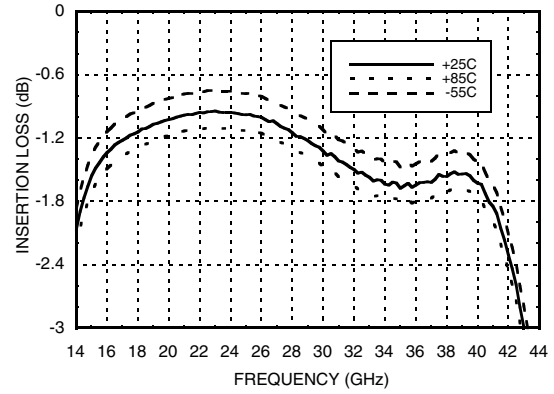

Isolation

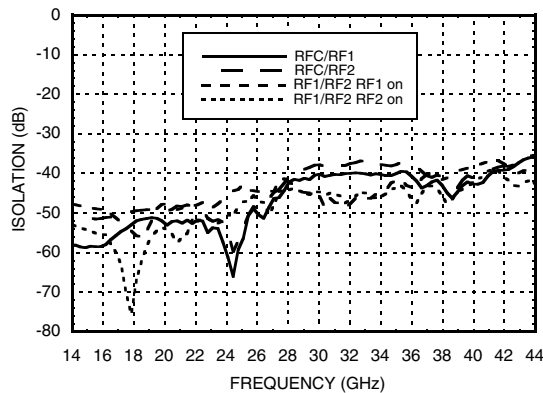

Return Loss

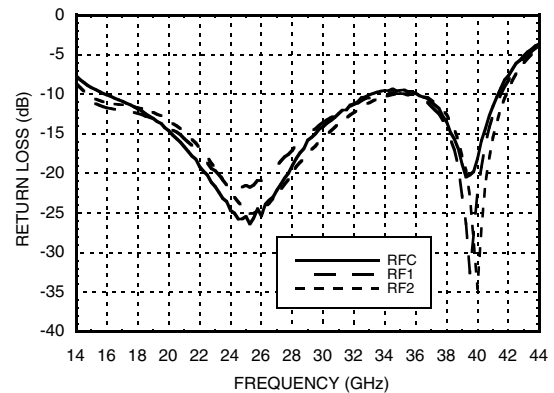

**Insertion Loss vs. Pin,
RFC to RF1, F = 25 GHz**

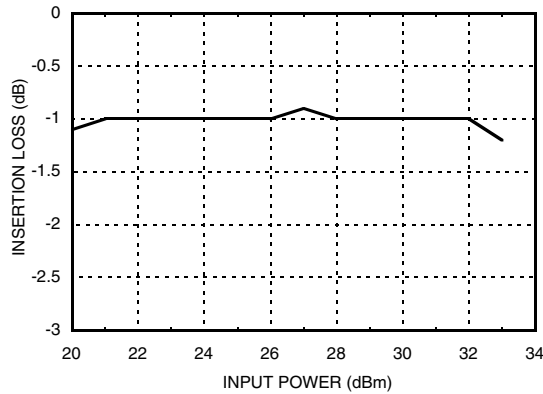

**Insertion Loss vs. Pin,
RFC to RF2, F = 25 GHz**

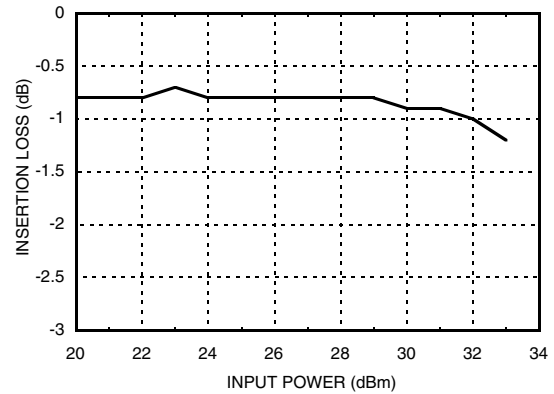

**PIN MMIC HIGH ISOLATION
SPDT SWITCH, 18 - 40 GHz**

IP3 RFC to RF1 and RFC to RF2

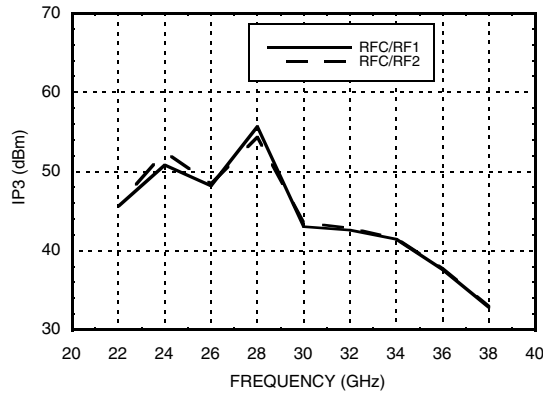

Absolute Maximum Ratings

RF Input Power	35 dBm
Negative Control Voltage	-15 V
Positive Bias Current	80 mA
Storage Temperature	-65 to +150 °C
Operating Temperature	-55 to +85 °C



**ELECTROSTATIC SENSITIVE DEVICE
OBSERVE HANDLING PRECAUTIONS**

7

Control Voltages

State	RFC - RF1	RFC - RF2	CNTL1	CNTL2
1	IL	Isol	-10V	+30mA / 1.29V
2	Isol	IL	+30mA / 1.29V	-10V

[Note 1] Diodes are reversed biased for the insertion path.

[Note 2] Diodes are forward biased for the isolation path. The forward voltage across the diodes is 1.29V.

Equivalent Schematic

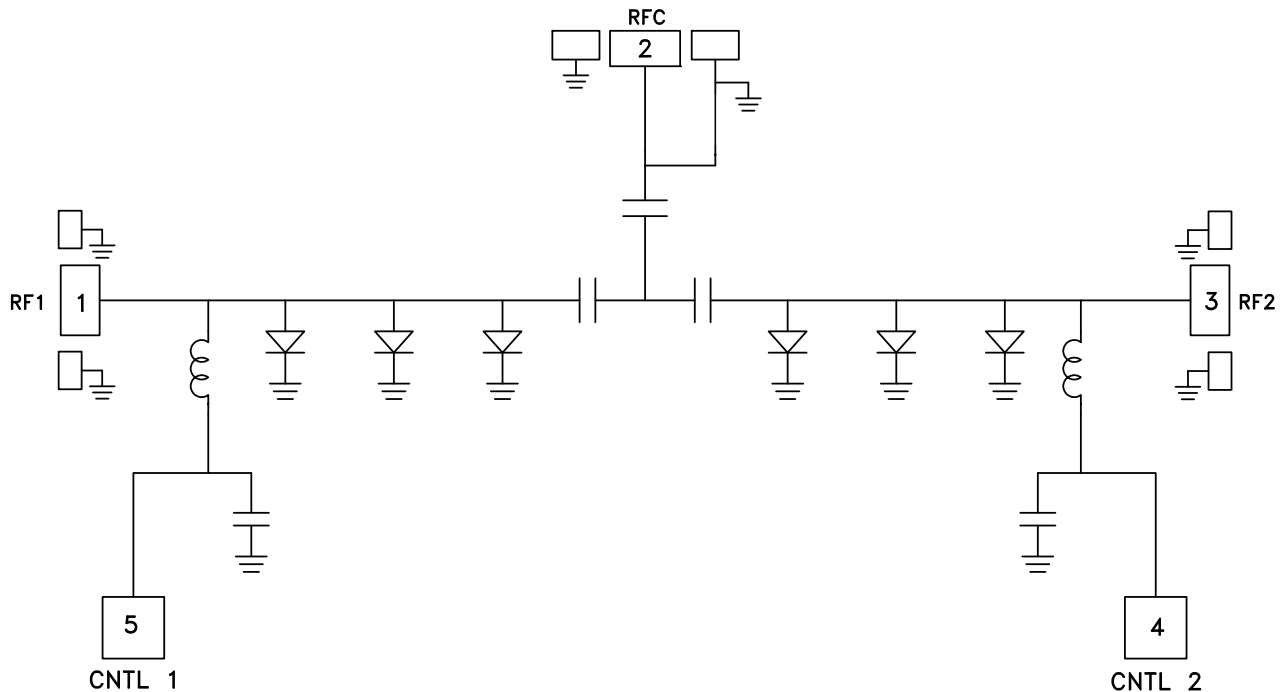

For price, delivery and to place orders: Hittite Microwave Corporation, 2 Elizabeth Drive, Chelmsford, MA 01824
Phone: 978-250-3343 Fax: 978-250-3373 Order On-line at www.hittite.com

www.BDTIC.com/Hittite/

**PIN MMIC HIGH ISOLATION
SPDT SWITCH, 18 - 40 GHz**

Outline Drawing

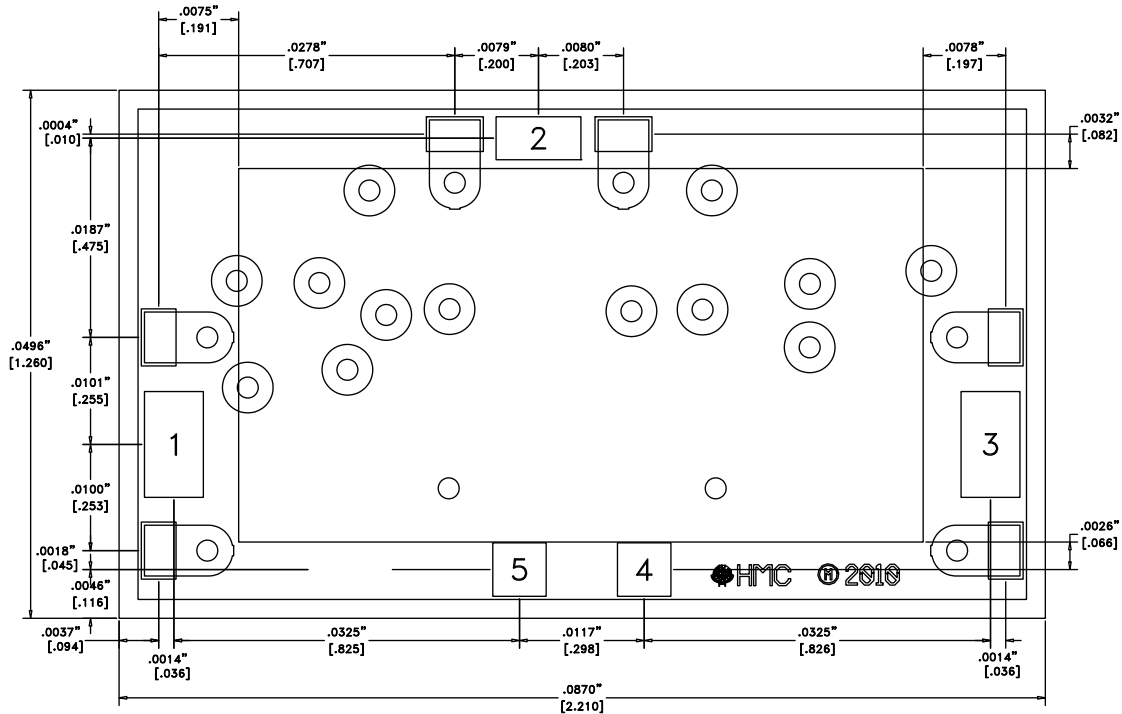

Die Packaging Information [1]

Standard	Alternate
GP-2 (Gel Pack)	[2]

[1] Refer to the "Packaging Information" section for die packaging dimensions.

[2] For alternate packaging information contact Hittite Microwave Corporation.

NOTES:

1. ALL DIMENSIONS ARE IN INCHES [MM]
2. DIE THICKNESS IS .004"
3. TYPICAL BOND PAD IS .004" SQUARE
4. BACKSIDE METALIZATION: GOLD
5. BACKSIDE METAL IS GROUND
6. BOND PAD METALIZATION: GOLD
7. NO CONNECTION REQUIRED FOR UNLABELED BOND PADS.
8. OVERALL DIE SIZE ±.002"

**PIN MMIC HIGH ISOLATION
SPDT SWITCH, 18 - 40 GHz**

Pad Descriptions

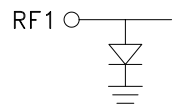
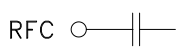
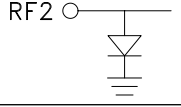
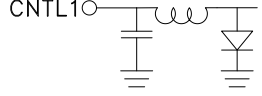
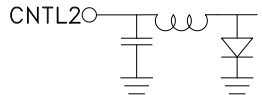
Pad Number	Function	Description	Interface Schematic
1	RF1	RF signal contains DC control voltage.. External DC blocking capacitor is required.	
2	RFC	RF common port, this port is AC coupled.	
3	RF2	RF signal contains DC control voltage. External DC blocking capacitor is required.	
4	CNTL1	Switch control input, see "Control Voltages" table.	
5	CNTL2	Switch control input, see "Control Voltage" table.	

Assembly Diagram

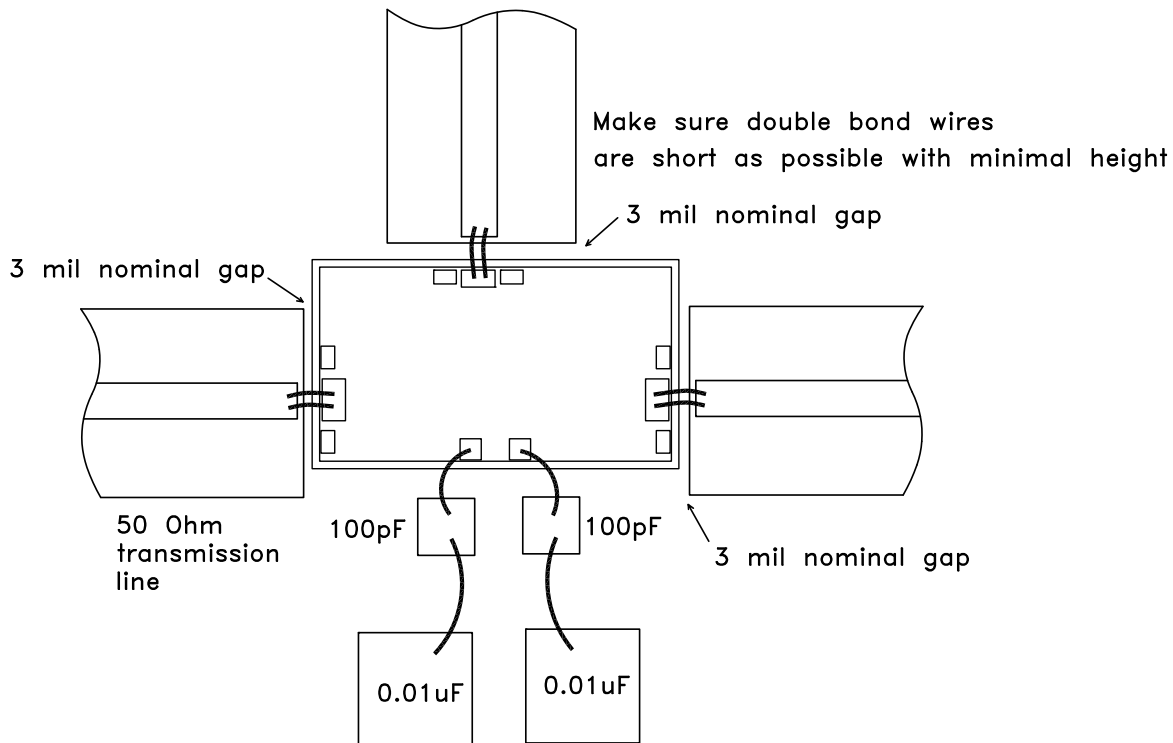

**PIN MMIC HIGH ISOLATION
 SPDT SWITCH, 18 - 40 GHz**
Mounting & Bonding Techniques for Millimeterwave GaAs MMICs

The die should be attached directly to the ground plane eutectically or with conductive epoxy (see HMC general Handling, Mounting, Bonding Note).

50 Ohm Microstrip transmission lines on 0.127mm (5 mil) thick alumina thin film substrates are recommended for bringing RF to and from the chip (Figure 1). If 0.254mm (10 mil) thick alumina thin film substrates must be used, the die should be raised 0.150mm (6 mils) so that the surface of the die is coplanar with the surface of the substrate. One way to accomplish this is to attach the 0.102mm (4 mil) thick die to a 0.150mm (6 mil) thick molybdenum heat spreader (moly-tab) which is then attached to the ground plane (Figure 2).

Microstrip substrates should be brought as close to the die as possible in order to minimize bond wire length. Typical die-to-substrate spacing is 0.076mm (3 mils).

Handling Precautions

Follow these precautions to avoid permanent damage.

Storage: All bare die are placed in either Waffle or Gel based ESD protective containers, and then sealed in an ESD protective bag for shipment. Once the sealed ESD protective bag has been opened, all die should be stored in a dry nitrogen environment.

Cleanliness: Handle the chips in a clean environment. DO NOT attempt to clean the chip using liquid cleaning systems.

Static Sensitivity: Follow ESD precautions to protect against ESD strikes.

Transients: Suppress instrument and bias supply transients while bias is applied. Use shielded signal and bias cables to minimize inductive pick-up.

General Handling: Handle the chip along the edges with a vacuum collet or with a sharp pair of bent tweezers. The surface of the chip has fragile air bridges and should not be touched with vacuum collet, tweezers, or fingers.

Mounting

The chip is back-metallized and can be die mounted with AuSn eutectic preforms or with electrically conductive epoxy. The mounting surface should be clean and flat.

Epoxy Die Attach: Apply a minimum amount of epoxy to the mounting surface so that a thin epoxy fillet is observed around the perimeter of the chip once it is placed into position. Cure epoxy per the manufacturer's schedule.

Wire Bonding

Ball or wedge bond with 0.025 mm (1 mil) diameter pure gold wire (DC bias, IF1 and IF2) or Ribbon Bond (RF and LO ports) 0.076 mm x 0.013 mm (3 mil x 0.5 mil) size is recommended. Thermosonic wirebonding with a nominal stage temperature of 150 °C and a ball bonding force of 40 to 50 grams or wedge bonding force of 18 to 22 grams is recommended. Use the minimum level of ultrasonic energy to achieve reliable wirebonds. Wirebonds should be started on the chip and terminated on the package or substrate. All bonds should be as short as possible <0.31 mm (12 mils).

