

## Features

- 35 dB Voltage Variable Attenuation at 1 GHz
- Single Voltage Control: 0 to -4 Volts
- Low DC Power Consumption
- Nanosecond Switching Speed
- Temperature Range: -40°C to +85°C
- SOIC-14 Plastic Package
- Tape and Reel Packaging Available

## Description

M/A-COM's AT-635 is a GaAs MMIC voltage variable absorptive attenuator in a low cost SOIC 14-lead surface mount plastic package. The AT-635 is ideally suited for use where attenuation fine tuning, fast switching and very low power consumption are required.

Typical applications include radio, cellular, GPS equipment and other automatic gain/level control circuits.

The AT-635 is fabricated with a monolithic GaAs MMIC using a mature 1-micron process. The process features full chip passivation for increased performance and reliability.

## Ordering Information <sup>1,2</sup>

Part Number	Package
AT-635	Bulk Packaging
AT-635TR	Tape and Reel
AT-635SMB	Sample Board

1. Reference Application Note M513 for reel size information.
2. All sample boards include 5 loose parts.

## Functional Schematic

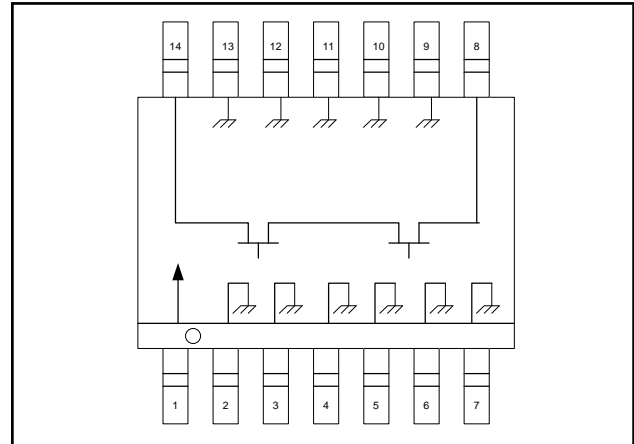

## Pin Configuration

Pin No.	Function	Pin No.	Function
1	V <sub>C</sub>	8	RF2
2	Ground	9	Ground
3	Ground	10	Ground
4	Ground	11	Ground
5	Ground	12	Ground
6	Ground	13	Ground
7	Ground	14	RF1

## Absolute Maximum Ratings <sup>3,4</sup>

Parameter	Absolute Maximum
Input Power	+21 dBm
Control Voltage	-8.5 V ≤ V <sub>C</sub> ≤ +5 V
Operating Temperature	-40°C to +85°C
Storing Temperature	-65°C to +150°C

3. Exceeding any one or combination of these limits may cause permanent damage to this device.
4. M/A-COM does not recommend sustained operation near these survivability limits.

## Voltage Variable Absorptive Attenuator 35 dB, DC - 2.0 GHz

Rev. V7

### Electrical Specifications: $T_A = 25^\circ\text{C}$ , $Z_0 = 50 \Omega$

Parameter	Test Conditions <sup>5</sup>	Units	Min.	Typ.	Max.
Insertion Loss	DC - 0.5 GHz	dB	—	6.7	7.0
	0.5 - 1.0 GHz	dB	—	7.2	7.4
	1.0 - 2.0 GHz	dB	—	7.5	7.8
Flatness (Peak to Peak)	10 dB Attenuation – DC - 2.0 GHz	dB	—	$\pm 1.0$	$\pm 1.3$
	20 dB Attenuation – DC - 2.0 GHz	dB	—	$\pm 1.2$	$\pm 1.5$
	30 dB Attenuation – DC - 2.0 GHz	dB	—	$\pm 1.2$	$\pm 1.5$
VSWR		Ratio	—	2.0:1	—
Trise, Tfall	10% to 90% RF, 90% to 10% RF	nS	—	2	—
Ton, Toff	50% Control to 90% RF, 50% Control to 10% RF	nS	—	4	—
Transients	In Band	mV	—	30	—
Power Handling	Linear Operation	dBm	—	—	13
	Absolute maximum Input Power	dBm	—	—	21
IP <sub>2</sub>	0.05 GHz	dBm	—	34	—
	0.5 - 2.0 GHz Measured Relative to Input Power (For two-tone Input Power Up to +5 dBm)	dBm	—	47	—
IP <sub>3</sub>	0.05 GHz	dBm	18	31 <sup>6</sup>	—
	0.5 - 2.0 GHz Measured Relative to Input Power (For two-tone Input Power Up to +5 dBm)	dBm	18.5	36 <sup>6</sup>	—

5. Control voltage: 0 to -4 volts @ 20  $\mu\text{A}$  typical.

6. For levels above 6 dB attenuation. For levels below 6 dB, the minimum specification numbers apply.

### SOIC-14<sup>†</sup>

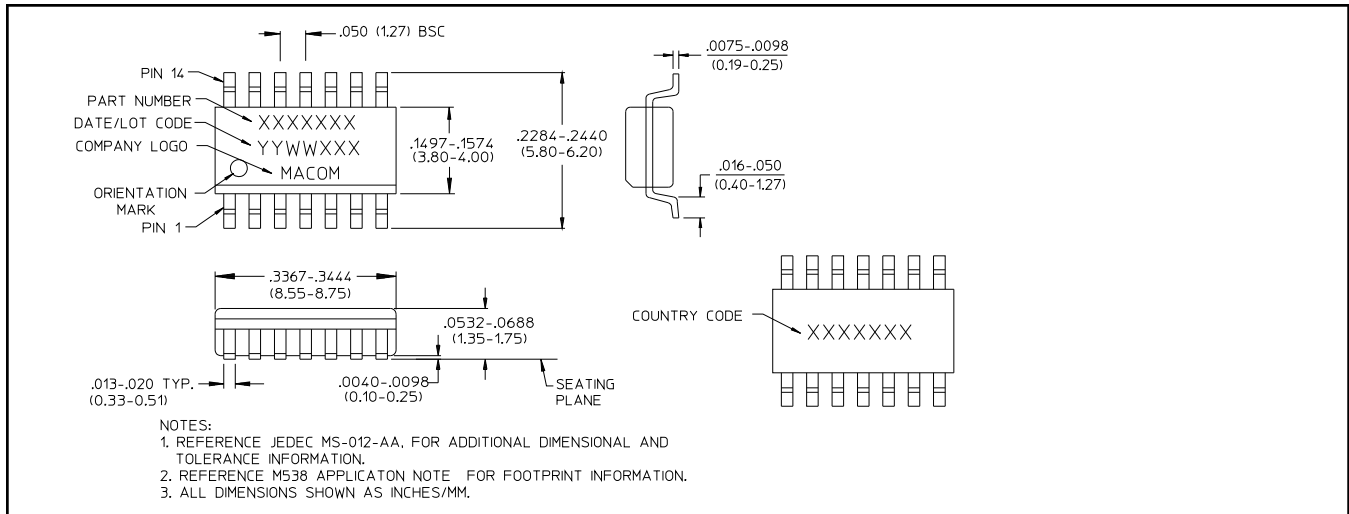

<sup>†</sup> Meets JEDEC moisture sensitivity level 1 requirements.

2

**ADVANCED:** Data Sheets contain information regarding a product M/A-COM Technology Solutions is considering for development. Performance is based on target specifications, simulated results, and/or prototype measurements. Commitment to develop is not guaranteed.

**PRELIMINARY:** Data Sheets contain information regarding a product M/A-COM Technology Solutions has under development. Performance is based on engineering tests. Specifications are typical. Mechanical outline has been fixed. Engineering samples and/or test data may be available. Commitment to produce in volume is not guaranteed.

- **North America** Tel: 800.366.2266 / Fax: 978.366.2266
- **Europe** Tel: 44.1908.574.200 / Fax: 44.1908.574.300
- **Asia/Pacific** Tel: 81.44.844.8296 / Fax: 81.44.844.8298

Visit [www.macomtech.com](http://www.macomtech.com) for additional data sheets and product information.

M/A-COM Technology Solutions Inc. and its affiliates reserve the right to make changes to the product(s) or information contained herein without notice.

## Typical Performance Curves

Insertion Loss vs. Frequency

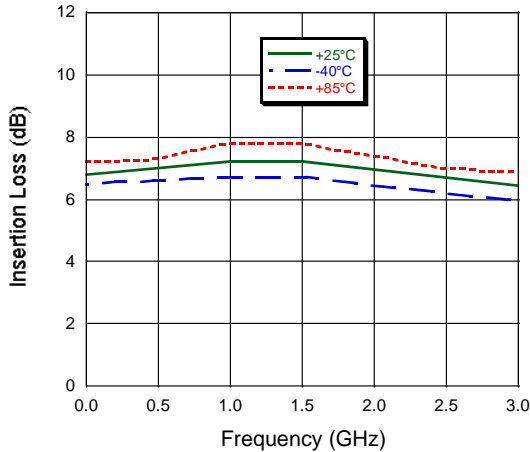

Attenuation vs. Control Voltage, F = 1 GHz

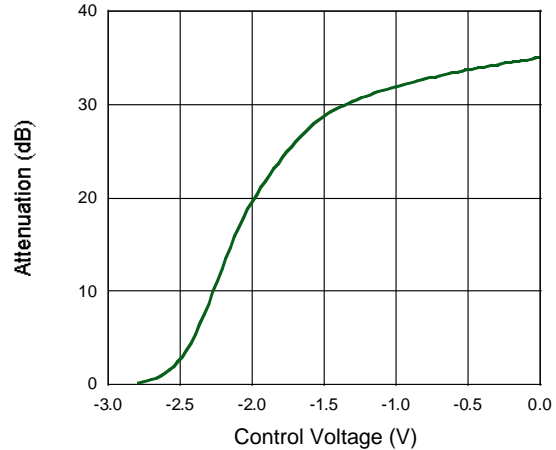

Attenuation vs. Frequency

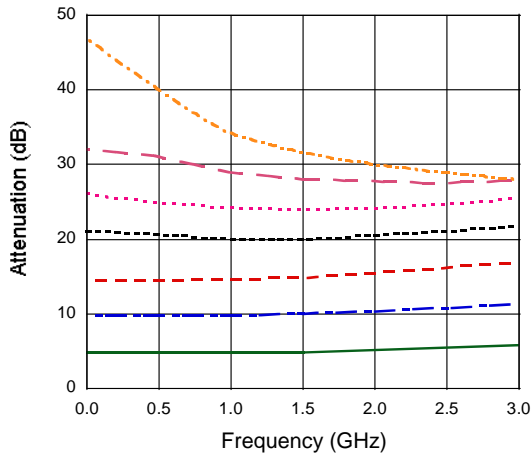

VSWR vs. Frequency

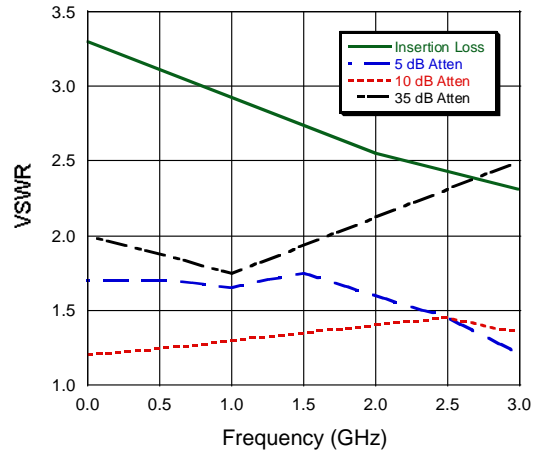

## Handling Procedures

Please observe the following precautions to avoid damage:

## Static Sensitivity

Gallium Arsenide Integrated Circuits are sensitive to electrostatic discharge (ESD) and can be damaged by static electricity. Proper ESD control techniques should be used when handling these devices.