

RF Power MOSFET Transistor 80W, 2-175MHz, 28V

M/A-COM Products
Released; RoHS Compliant

Features

- N-Channel enhancement mode device
- DMOS structure
- Lower capacitances for broadband operation
- High saturated output power
- Lower noise figure than bipolar devices

ABSOLUTE MAXIMUM RATINGS AT 25° C

Parameter	Symbol	Rating	Units
Drain-Source Voltage	V_{DS}	65	V
Gate-Source Voltage	V_{GS}	20	V
Drain-Source Current	I_{DS}	16	A
Power Dissipation	P_D	206	W
Junction Temperature	T_J	200	°C
Storage Temperature	T_{STG}	-65 to +150	°C
Thermal Resistance	θ_{JC}	0.85	°C/W

TYPICAL DEVICE IMPEDANCE

F (MHz)	Z_{IN} (Ω)	Z_{LOAD} (Ω)
30	5.4 - j4.4	5.7 + j4.7
50	2.5 - j4.4	3.4 + j3.5
100	1.6 - j3.4	2.4 + j2.4
175	0.7 - j1.2	1.7 + j0.8

$V_{DD} = 28V, I_{DQ} = 400mA, P_{OUT} = 80W$

Z_{IN} is the series equivalent input impedance of the device from gate to source.

Z_{LOAD} is the optimum series equivalent load impedance as measured from drain to ground.

ELECTRICAL CHARACTERISTICS AT 25°C

Parameter	Symbol	Min	Max	Units	Test Conditions
Drain-Source Breakdown Voltage	BV_{DSS}	65	-	V	$V_{GS} = 0.0V, I_{DS} = 20.0mA$
Drain-Source Leakage Current	I_{DSS}	-	4.0	mA	$V_{GS} = 28.0V, V_{DS} = 0.0V$
Gate-Source Leakage Current	I_{GSS}	-	4.0	μA	$V_{GS} = 20.0V, V_{DS} = 0.0V$
Gate Threshold Voltage	$V_{GS(TH)}$	2.0	6.0	V	$V_{DS} = 10.0V, I_{DS} = 400.0mA$
Forward Transconductance	G_M	2.0	-	S	$V_{DS} = 10.0V, I_{DS} = 4.0A, \Delta V_{GS} = 1.0V, 80\mu s$ Pulse
Input Capacitance	C_{ISS}	-	180	pF	$V_{DS} = 28.0V, F = 1.0MHz$
Output Capacitance	C_{OSS}	-	160	pF	$V_{DS} = 28.0V, F = 1.0MHz$
Reverse Capacitance	C_{RSS}	-	32	pF	$V_{DS} = 28.0V, F = 1.0MHz$
Power Gain	G_P	13	-	dB	$V_{DD} = 28.0V, I_{DQ} = 400mA, P_{OUT} = 80.0W, F = 175MHz$
Drain Efficiency	η_D	60	-	%	$V_{DD} = 28.0V, I_{DQ} = 400mA, P_{OUT} = 80.0W, F = 175MHz$
Load Mismatch Tolerance	VSWR-T	-	30:1	-	$V_{DD} = 28.0V, I_{DQ} = 400mA, P_{OUT} = 80.0W, F = 175MHz$

Package Outline

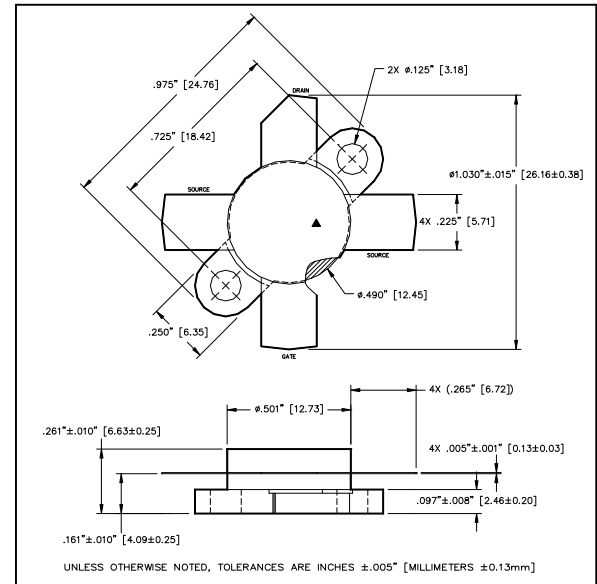

LETTER DIM	MILLIMETERS		INCHES	
	MIN	MAX	MIN	MAX
A	24.64	24.89	.970	.980
B	18.29	18.54	.720	.730
C	25.91	26.42	1.020	1.040
D	12.60	12.85	.496	.506
E	6.22	6.48	.245	.255
F	5.59	5.84	.220	.230
G	3.05	3.30	.120	.130
H	2.21	2.59	.087	.102
J	3.91	4.42	.154	.174
K	6.53	7.34	.257	.289
L	.10	.15	.004	.006

Typical Broadband Performance Curves

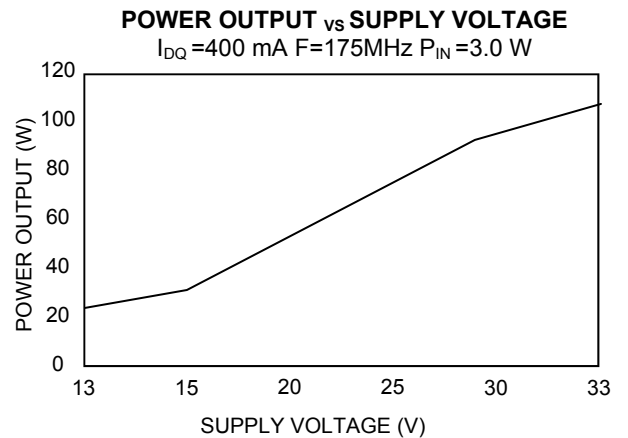
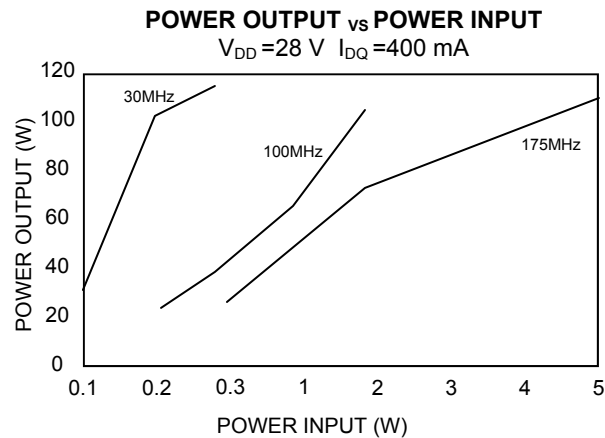
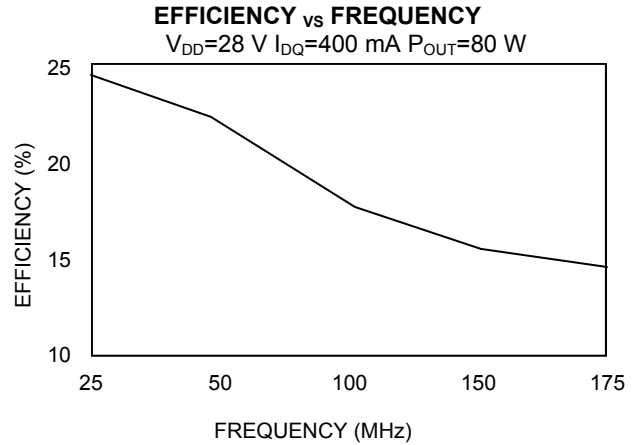
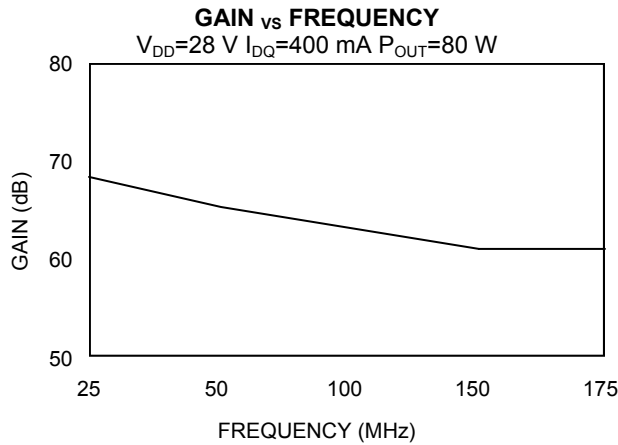

RF Power MOSFET Transistor 80W, 2-175MHz, 28V

M/A-COM Products
Released; RoHS Compliant

TEST FIXTURE SCHEMATIC

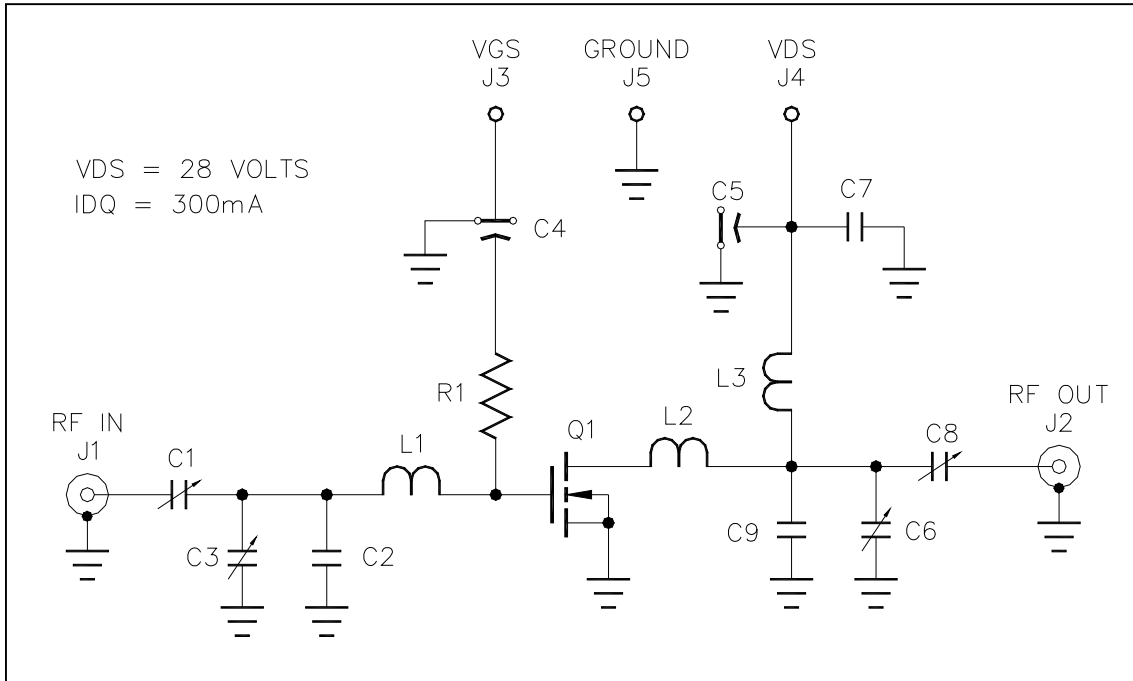

TEST FIXTURE ASSEMBLY

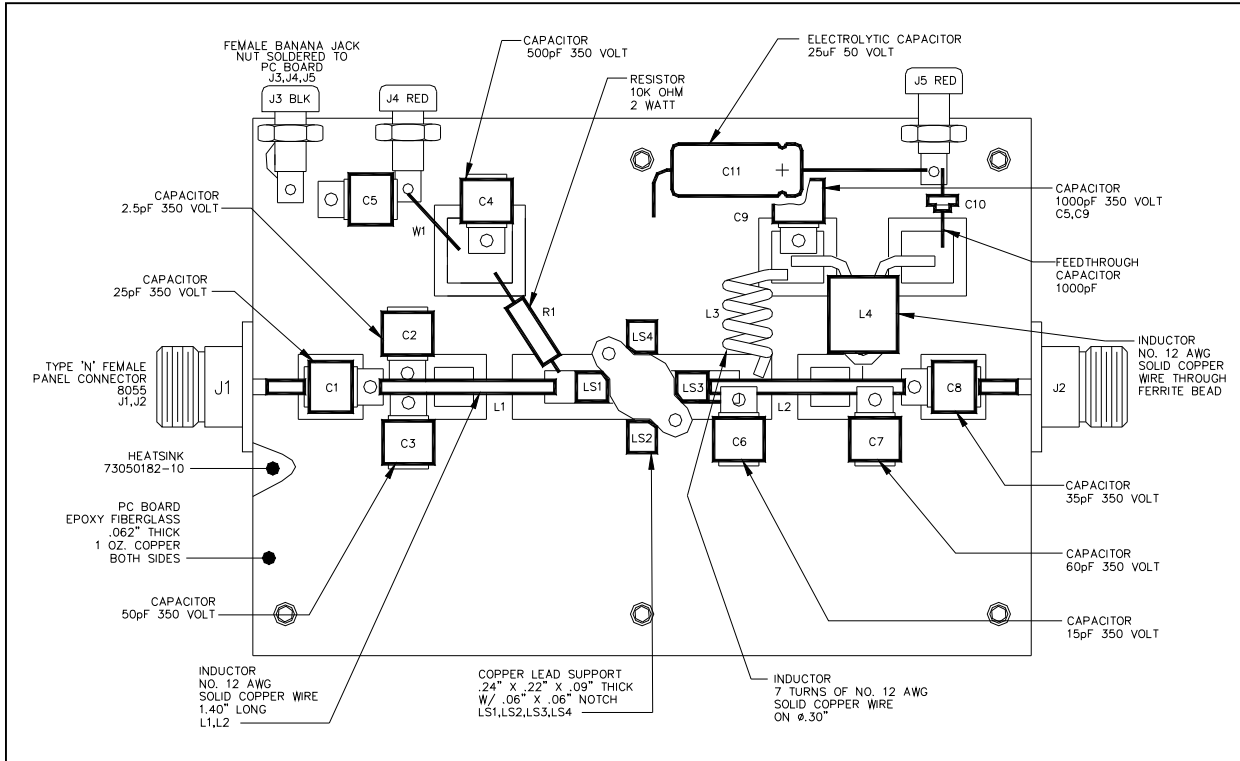

ADVANCED: Data Sheets contain information regarding a product M/A-COM Technology Solutions is considering for development. Performance is based on target specifications, simulated results, and/or prototype measurements. Commitment to develop is not guaranteed.

PRELIMINARY: Data Sheets contain information regarding a product M/A-COM Technology Solutions has under development. Performance is based on engineering tests. Specifications are typical. Mechanical outline has been fixed. Engineering samples and/or test data may be available. Commitment to produce in volume is not guaranteed.

• **North America** Tel: 800.366.2266 / Fax: 978.366.2266

• **Europe** Tel: 44.1908.574.200 / Fax: 44.1908.574.300

• **Asia/Pacific** Tel: 81.44.844.8296 / Fax: 81.44.844.8298

Visit www.macontech.com for additional data sheets and product information.

M/A-COM Technology Solutions Inc. and its affiliates reserve the right to make changes to the product(s) or information contained herein without notice.