

### Features

- LO 2.0 TO 26.0 GHz
- RF 2.0 TO 26.0 GHz
- IF 1.0 TO 15.0 GHz
- LO DRIVE +10 dBm (nominal)
- HIGH COMPRESSION POINT
- VERY WIDE BANDWIDTH

### Description

The M50 is a triple balanced mixer, designed for use in military, commercial and test equipment applications. The design utilizes Schottky ring quad diodes and broadband soft dielectric baluns to attain excellent performance. The use of high temperature solder and welded assembly processes used internally makes it ideal for use in manual, semi-automated assembly. Environmental screening available to MIL-STD-883, MIL-STD-202 or MIL-DTL-28837, consult factory.

### Product Image

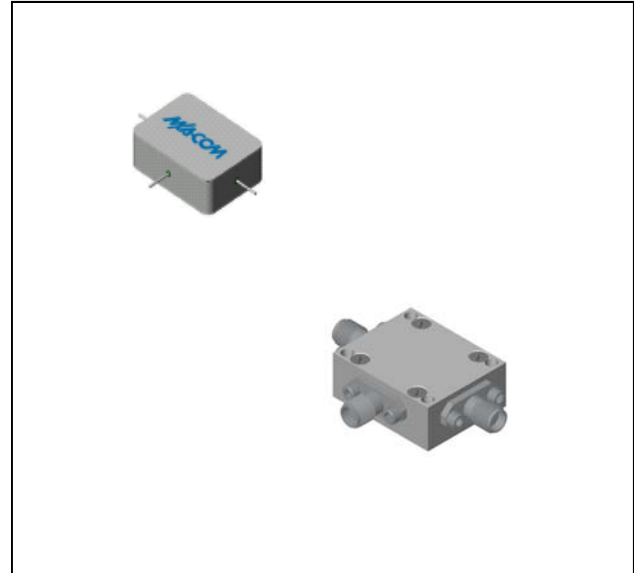

### Ordering Information

Part Number	Package
M50	Minpac
M50C	SMA Connectorized

### Electrical Specifications: $Z_0 = 50\Omega$ $L_o = +10$ dBm (Downconverter application only)

Parameter	Test Conditions	Units	Typical	Guaranteed	
				+25°C	-54° to +85°C *
SSB Conversion Loss (max) & SSB Noise Figure (max)	fR = 2.5 to 18 GHz, fL = 2 to 18 GHz, fI = 2 to 10 GHz fR = 2 to 18 GHz, fL = 2 to 26 GHz, fI = 2 to 12 GHz fR = 2 to 26 GHz, fL = 2 to 26 GHz, fI = 2 to 15 GHz	dB	7.5	9.5	10.0
			8.0	10.5	11.0
			9.0	11.5	12.0
Isolation, L to R (min)	fL = 2 to 3 GHz fL = 3 to 26 GHz	dB	30	15	13
			22	20	18
Isolation, L to I (min)	fL = 2 to 7 GHz fL = 7 to 26 GHz	dB	30	15	13
			22	20	20
1 dB Conversion Comp.	fL @ +10 dBm	dBm	+5		
Input IP3	fR1 = 5 GHz @ -6 dBm, fR2 = 5.01 GHz @ -6 dBm, fL = 8 GHz @ 10 dBm fR1 = 25 GHz @ -6 dBm, fR2 = 25.01 GHz @ -6 dBm, fL = 15 GHz @ 10 dBm	dBm	+15		
			+15		

\* The M50C specification limits apply at 0°C to +50°C.

### Typical Performance Curves

**Conversion Loss vs. LO Drive Level**

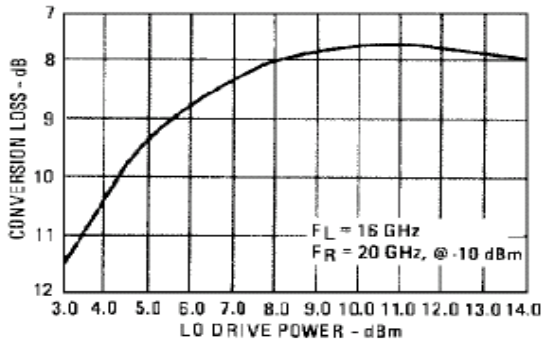

**Isolation vs. Frequency**

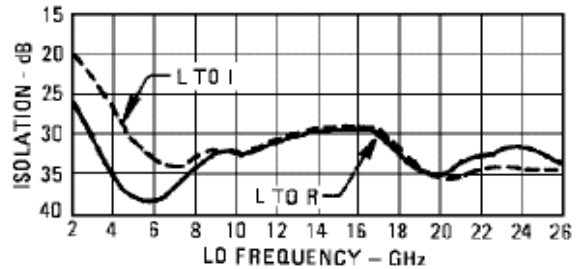

**Conversion Loss vs. Frequency**

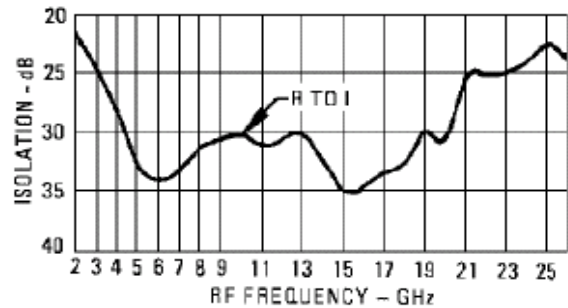
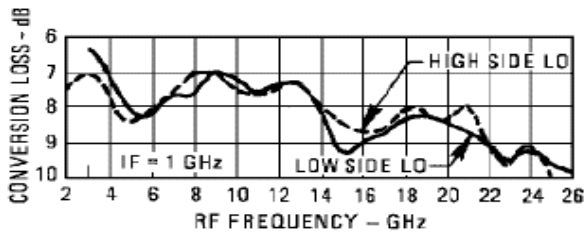

**L-Port VSWR**

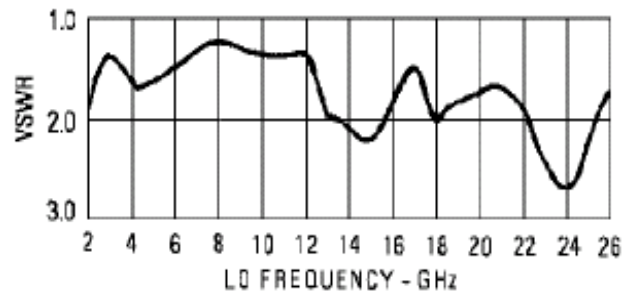

**Conversion Loss vs. Frequency**

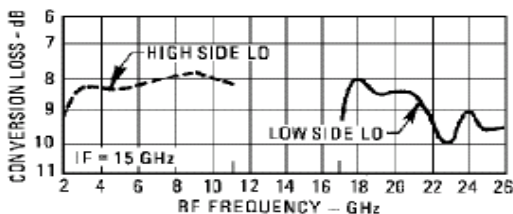
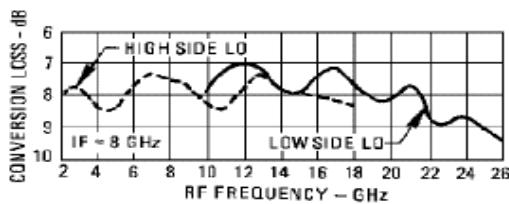

### Absolute Maximum Ratings

Parameter	Absolute Maximum
Operating Temperature	-54°C to +100°C
Storage Temperature	-65°C to +100°C
Peak Input Power	+26 dBm max @ +25°C +22 dBm max @ +100°C
Peak Input Current	mA DC

### Outline Drawing: Minpac \*

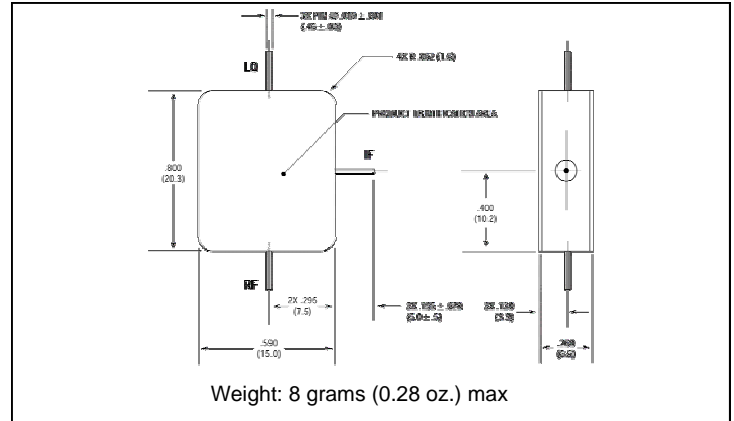

### Outline Drawing: SMA Connectorized \*

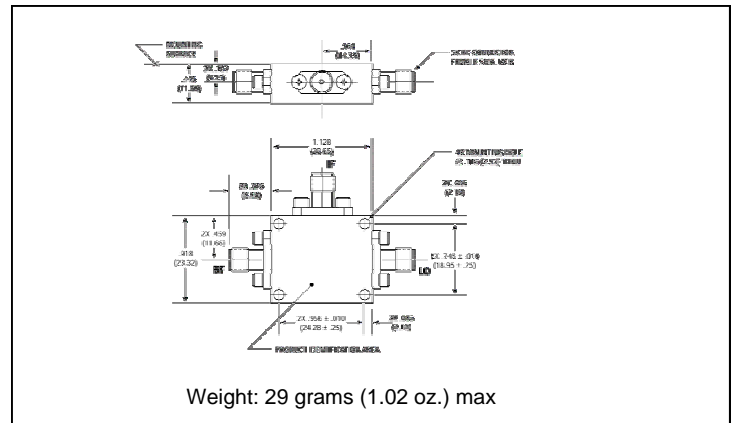

Dimensions are inches (millimeters) ±0.015 (0.38) unless otherwise specified.

### I-Port VSWR

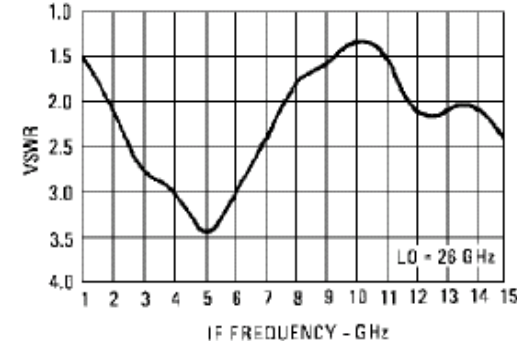
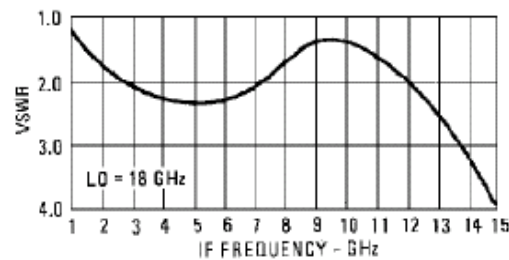
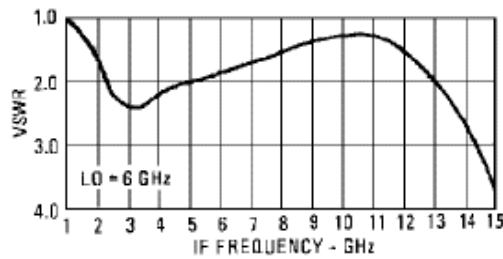
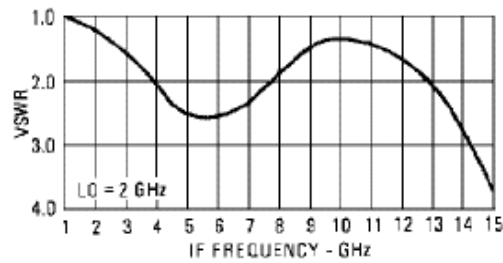

### R-Port VSWR

