

# MA4VAT904-1061T



## High IIP3 PIN Diode Variable Attenuator 0.8 - 1.0 GHz

Rev. V4

### Features

- 1.0 dB Insertion Loss, Typical
- 12 dB Return Loss, Typical
- 25 dB Attenuation, Typical
- 45 dBm IIP3, Typical ( 1MHz Offset, @ +0dBm Pinc )
- SOIC-8 Surface Mount Package
- RoHs Compliant

### Extra Features

- Covers the following Bands:
  - GSM
  - AMPS
- Usable Bandwidth: 0.60 GHz to 1.20 GHz
- 1.5 dB Insertion Loss, Typical
- 1.8:1 VSWR, Typical
- 18.5 dB Attenuation, Typical

### Description and Applications

M/A-COM's MA4VAT904-1061T is a HMIC PIN Diode Variable Attenuator which utilizes an integrated 90 degree 3dB hybrid with a pair of Silicon PIN Diodes to perform the required attenuation function as D.C. Voltage (Current) is applied.

This device operates from 0 to 1.9 Volts at 1.89 mA typical control current for maximum attenuation. The user can add external biasing resistors to the bias ports for higher voltage requirements as required.

M/A-COM's MA4VAT904-1061T PIN Diode Variable Attenuator is designed for AGC Circuit Applications requiring:

- Lower Insertion Loss
- Lower distortion through attenuation
- Larger dynamic range for wide spread spectrum applications

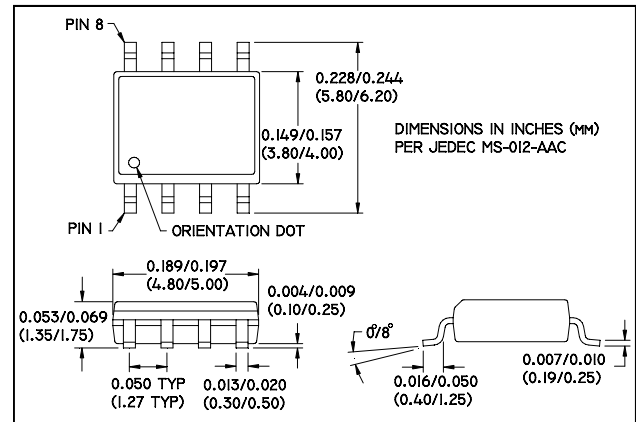

### SOIC-8 PIN Configuration (Topview)

PIN	Function	Comments
1	DC1	
2	GND	
3	GND	
4	RFin/out	Symmetrical as RF Input/Ouput
5	RFout/in	Symmetrical as RF Input/Ouput
6	GND	
7	GND	
8	DC2	

### Absolute Maximum Ratings @ +25 °C <sup>1,2</sup>

Parameter	Maximum Ratings
Operating Temperature	-40 °C to +85 °C
Storage Temperature	-65 °C to +150 °C
Junction Temperature	+175 °C
RF C.W. Incident Power	+33 dBm C.W.
Reversed Current @ -30 V	50nA
Control Current	50 mA per Diode

1. All the above values are at +25 °C, unless otherwise noted.
2. Exceeding these limits may cause permanent damage.

## High IIP3 PIN Diode Variable Attenuator 0.8 - 1.0 GHz

Rev. V4

### Electrical Specifications @ +25 °C

Parameter	Frequency Band	Unit	Min	Typ	Max
<b>No DC Bias RF Parameter</b>					
Insertion Loss	0.80 GHz—1.00 GHz	dB	-	1.0	1.2
Input Return Loss		dB	11	12	-
Output Return Loss		dB	11	12	-
P1dB		dBm	30	-	-
Input IP3		dBm	45	49	-
Control Voltage		V	-	0 V @ 0uA	-
<b>DC Bias RF Parameter</b>					
Maximum Attenuation	0.80 GHz—1.00 GHz	dB	18.5	24	-
Input Return Loss @ Max Attenuation		dB	15	21	-
Output Return Loss @ Max Attenuation		dB	15	21	-
Input IP3		dBm	36	39	-
Control Voltage @ Max Attenuation		V	-	1.9 V @ 1.89 mA	-
Control Current @ Max Attenuation	Bias = 1.9V	mA	1.2	1.8	2.4

### Typical RF Performance Over Industry Designated RF Frequency Bands <sup>3,4</sup>

Band		Freq	I. Loss	Att.	R. Loss	IIP3	Phase -Relative-
		(MHz)	(dB)	(dB)	(dB)	(dBm)	(Degree)
<b>AMPS</b>	<b>RX</b>	824-849	0.9	22	12	45	-15°
	<b>TX</b>	869-894	0.9	22	12	45	
<b>GSM</b>	<b>RX</b>	880-915	1.2	20	11	45	-20°
	<b>TX</b>	925-960	1.2	20	11	45	

3. All are typical values only.

4. Relative phase is the measured Insertion Phase difference between Insertion Loss and 15 dB Attenuation. (Please refer to the plots below)

# MA4VAT904-1061T



High IIP3 PIN Diode Variable Attenuator  
0.8 - 1.0 GHz

Rev. V4

## Plots of Typical RF Characteristics @ +25 °C

### Typical Insertion Loss & Attenuation

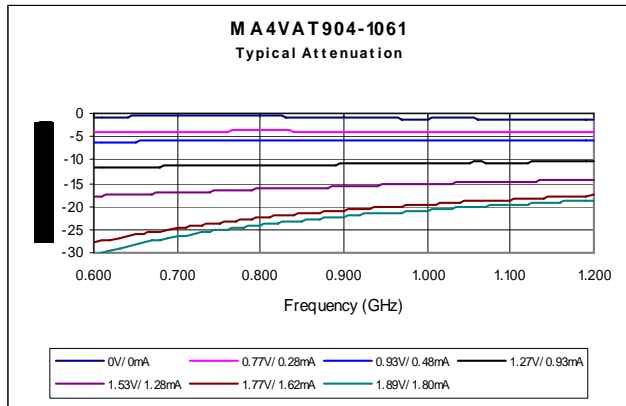

### Typical Attenuation vs Voltage

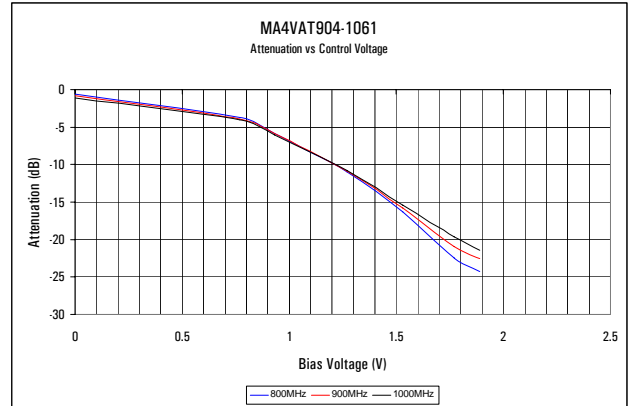

### Typical Return Loss @ All Attenuation Levels

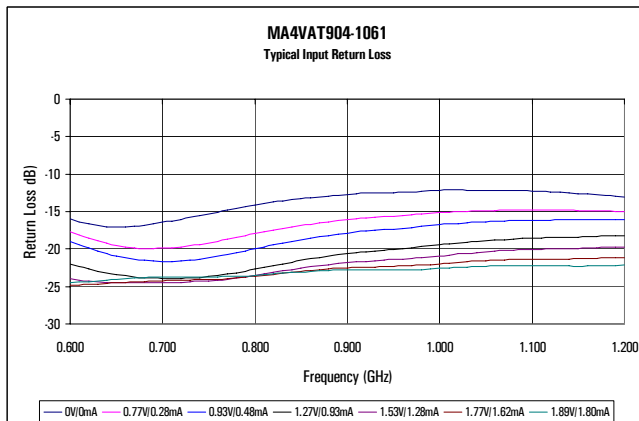

### Typical IIP3 vs Attenuation

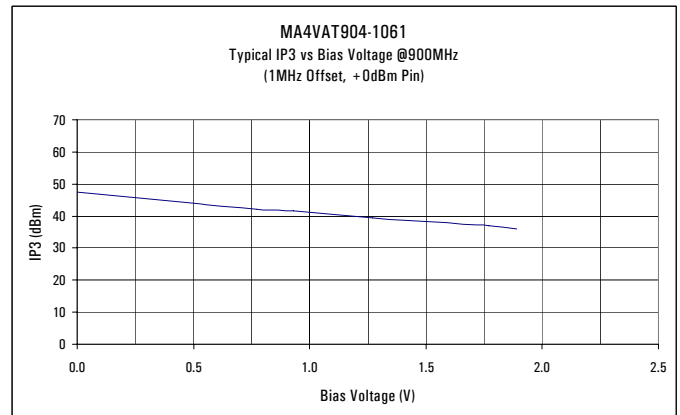

### Typical Relative Phase Shift Per Attenuation (Voltage)

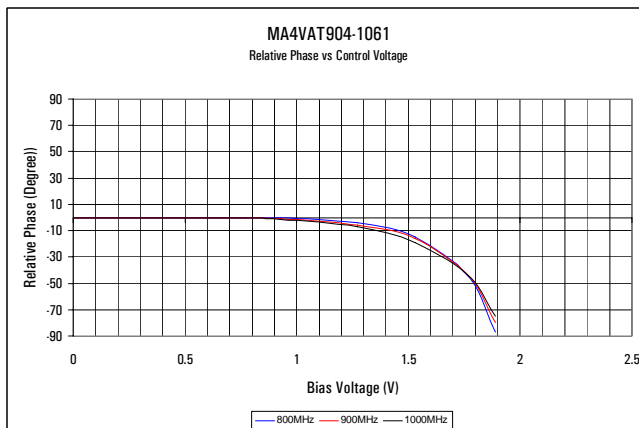

For Reference ONLY:

- Insertion Loss = 0.00 V @ 0.00 mA
- 5dB Attenuation = 0.94 V @ 0.49 mA
- 10dB Attenuation = 1.26 V @ 0.93 mA
- 15dB Attenuation = 1.50 V @ 1.22 mA
- 20dB Attenuation = 1.77V @ 1.60 mA

## Package PIN Designation, External Components, and Equivalent Circuit

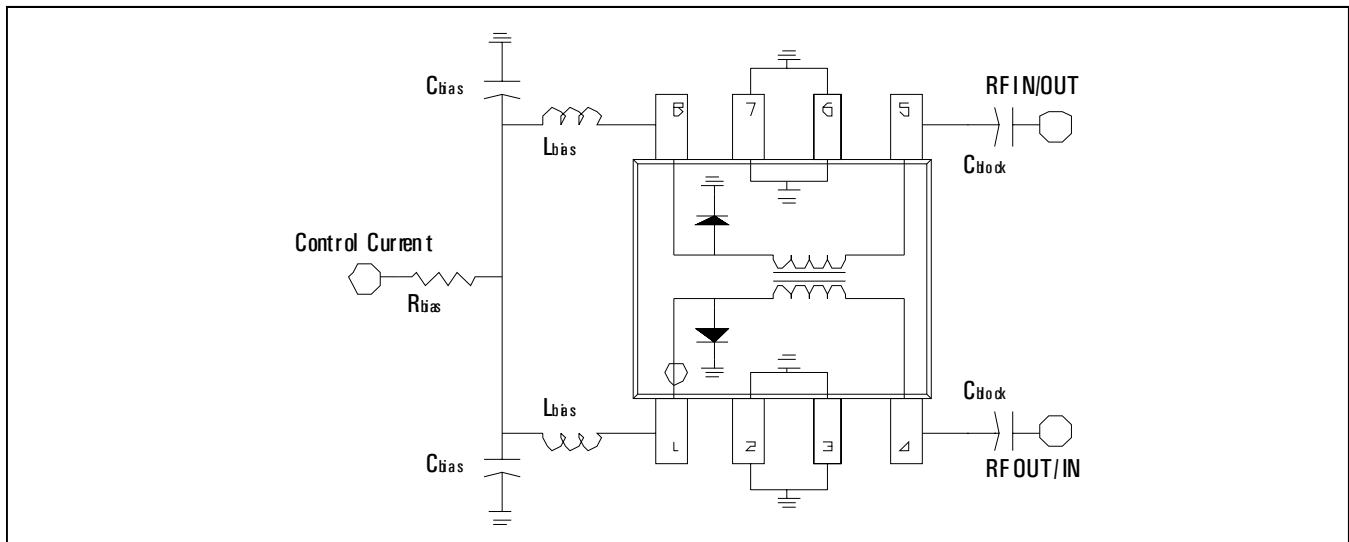
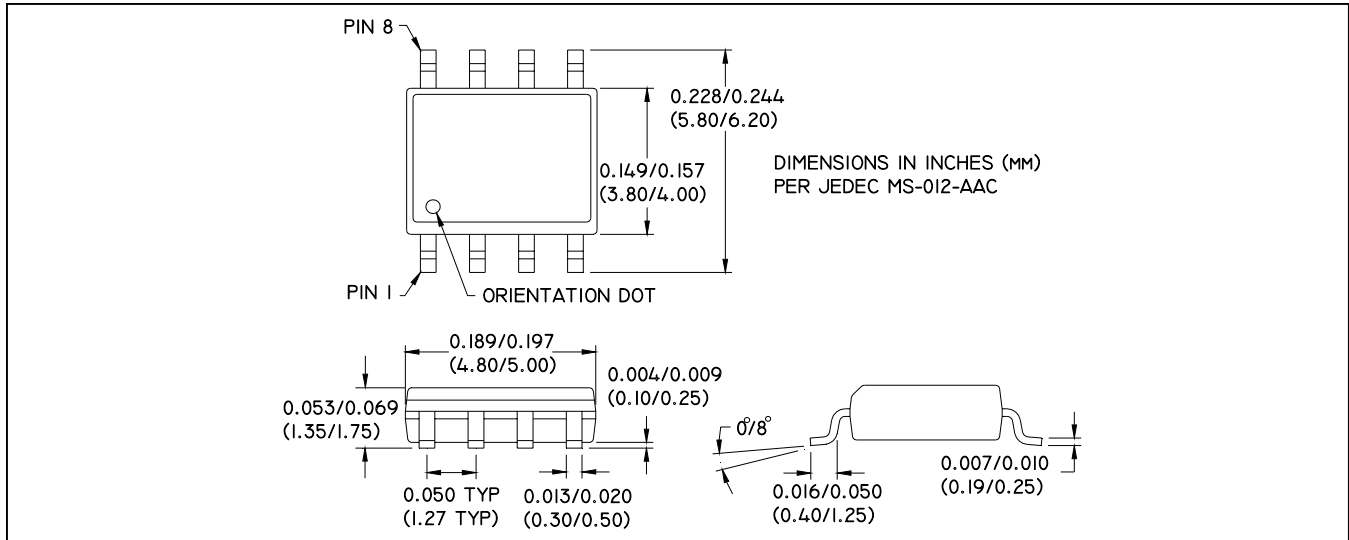

### External Bias Components

- Rbias= 680 Ohms ( 1.66 V, @1.50 mA )
- Lbias= 150 nH
- Cbias =100 pF
- Cblock =100 pF