

## GaAs MMIC Voltage Variable Absorptive Attenuator DC - 12 GHz

Rev. V4

### Features

- Single or Dual Bias Control
- Easily Cascadable
- Small Size
- Attenuation Flatness DC - 12 GHz  $\pm$  0.2 dB
- Low Control Current Consumption
- Low Phase Shift
- Up to 20 dB Matched Attenuation with Dual Bias
- RoHS\* Compliant

### Description

The MAAA2000G is a broadband GaAs MESFET MMIC voltage variable absorptive attenuator. Typical applications are for WLAN IEEE 802.11a+b/g, WiMAX IEEE 802.16, and MIMO. Other applications include test equipment requiring ultra fast switching speed.

The MAAA2000G is fabricated using a 1.0 micro gate length GaAs MESFET process. The process features full chip passivation for increased performance and reliability.

### Functional Schematic

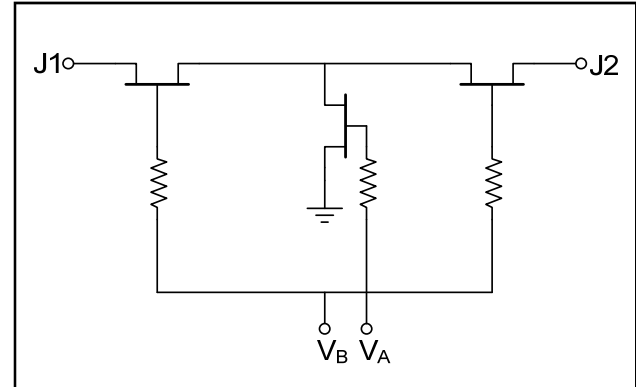

### Ordering Information

| Part Number | Package          |
|-------------|------------------|
| MAAA2000G   | DIE <sup>1</sup> |

1. Die quantity varies.

### Electrical Specifications: 0/-5 Vdc, 50 $\Omega$ , -55°C to +85°C

| Parameter  | Test Conditions                              | Units   | Min. | Typ. | Max.  |
|--|--|---------|------|------|-------|
| Insertion Loss <sup>2</sup>                                    | DC - 1.0 GHz                                 | dB      | —    | —    | 1.2   |
|  | DC - 2.0 GHz                                 |         | —    | —    | 1.4   |
|  | DC - 12.0 GHz                                |         | —    | —    | 1.5   |
| VSWR   | DC - 1.0 GHz                                 | Ratio   | —    | —    | 1.5:1 |
|  | DC - 2.0 GHz                                 |         | —    | —    | 1.5:1 |
|  | DC - 12.0 GHz                                |         | —    | —    | 1.8:1 |
| Relative Attenuation<br>(Matched)<br>(Reflective)<br>(Matched) | DC - 2.0 GHz                                 | dB      | 23   | —    | —     |
|  | DC - 2.0 GHz                                 |         | 40   | —    | —     |
|  | 2.0 - 12.0 GHz                               |         | 12   | —    | —     |
| Trise, Tfall   | 10% to 90% RF, 90% to 10% RF                 | ns      | —    | 7    | —     |
| Ton, Toff  | 50% Control to 90% RF, 50% Control to 10% RF | ns      | —    | 10   | —     |
| Transients   | In-band                                      | mV      | —    | 20   | —     |
| Input 1 dB Compression   | 0.5 - 4.0 GHz                                | dBm     | —    | 15   | —     |
| V <sub>IN</sub> Low  | 0 to -0.2 V                                  | $\mu$ A | —    | —    | 9     |
| V <sub>IN</sub> High   | -5 V   | $\mu$ A | —    | 50   | 100   |

2. Loss changes 0.00025 dB/°C (-55°C to +85°C.)

\*Restrictions on Hazardous Substances, European Union Directive 2002/95/EC.

**ADVANCED:** Data Sheets contain information regarding a product M/A-COM Technology Solutions is considering for development. Performance is based on target specifications, simulated results, and/or prototype measurements. Commitment to develop is not guaranteed.  
**PRELIMINARY:** Data Sheets contain information regarding a product M/A-COM Technology Solutions has under development. Performance is based on engineering tests. Specifications are typical. Mechanical outline has been fixed. Engineering samples and/or test data may be available. Commitment to produce in volume is not guaranteed.

• **North America** Tel: 800.366.2266 / Fax: 978.366.2266  
 • **Europe** Tel: 44.1908.574.200 / Fax: 44.1908.574.300  
 • **Asia/Pacific** Tel: 81.44.844.8296 / Fax: 81.44.844.8298  
 Visit [www.macomtech.com](http://www.macomtech.com) for additional data sheets and product information.

M/A-COM Technology Solutions Inc. and its affiliates reserve the right to make changes to the product(s) or information contained herein without notice.

## Typical Performance Curves @ 25°C

**Insertion Loss**

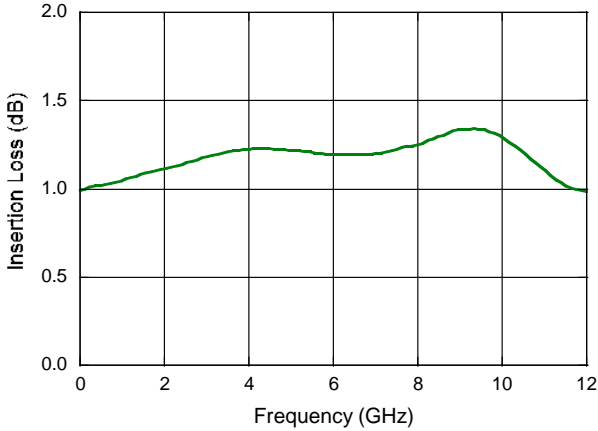

**Isolation**

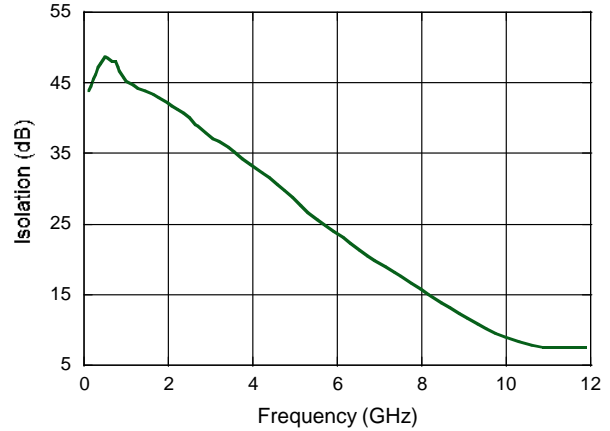

**VSWR**

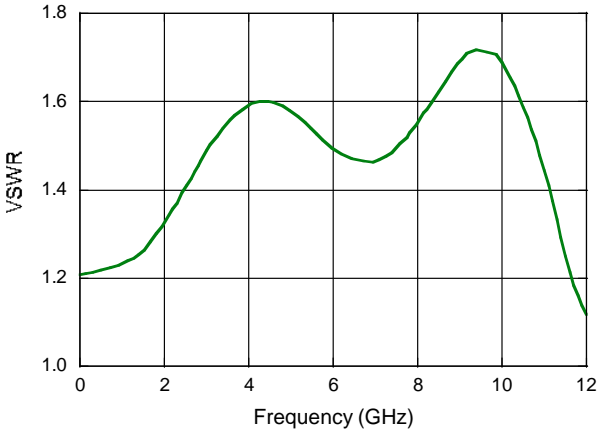

**Attenuation @ 2 GHz**

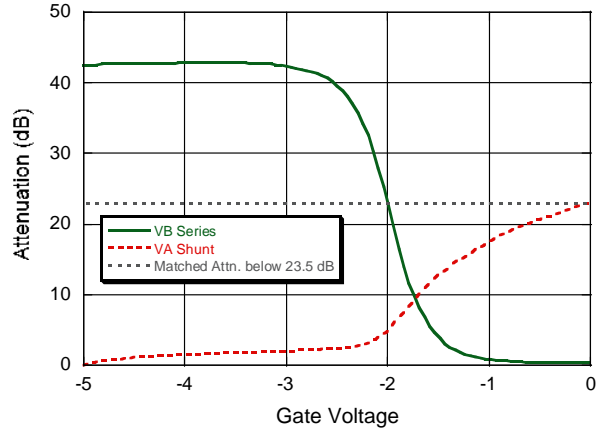

**Attenuation @ 12 GHz**

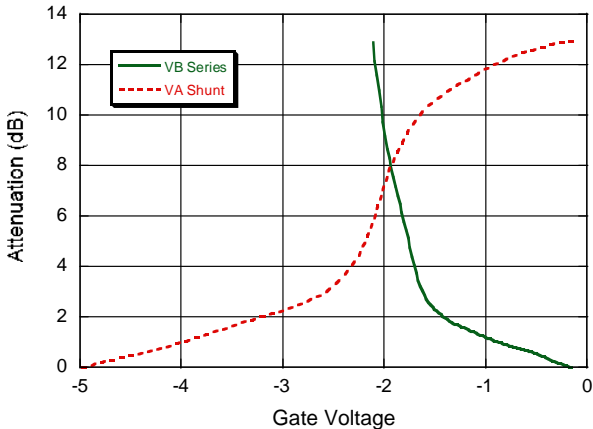

## Absolute Maximum Ratings <sup>3,4</sup>

| Parameter                         | Absolute Maximum     |
|-----------------------------------|----------------------|
| Control Voltage                   | -8.5 V <sub>DC</sub> |
| Input RF Power (500 MHz - 12 GHz) | +34 dBm              |
| Storage Temperature               | -65°C to +175°C      |
| Operating Temperature             | +175°C               |

- Exceeding any one or combination of these limits may cause permanent damage to this device.
- M/A-COM Technology Solutions does not recommend sustained operation near these survivability limits.

**ADVANCED:** Data Sheets contain information regarding a product M/A-COM Technology Solutions is considering for development. Performance is based on target specifications, simulated results, and/or prototype measurements. Commitment to develop is not guaranteed.  
**PRELIMINARY:** Data Sheets contain information regarding a product M/A-COM Technology Solutions has under development. Performance is based on engineering tests. Specifications are typical. Mechanical outline has been fixed. Engineering samples and/or test data may be available. Commitment to produce in volume is not guaranteed.

• **North America** Tel: 800.366.2266 / Fax: 978.366.2266  
 • **Europe** Tel: 44.1908.574.200 / Fax: 44.1908.574.300  
 • **Asia/Pacific** Tel: 81.44.844.8296 / Fax: 81.44.844.8298  
 Visit [www.macomtech.com](http://www.macomtech.com) for additional data sheets and product information.

M/A-COM Technology Solutions Inc. and its affiliates reserve the right to make changes to the product(s) or information contained herein without notice.

## Handling Procedures

Permanent damage to the MAAA2000G may occur if the following precautions are not adhered to:

- A. Cleanliness - The MAAA2000G should be handled in a clean environment. DO NOT attempt to clean assembly after the MAAA2000G is installed.
- B. Static Sensitivity - All die handling equipment and personnel should be DC grounded.
- C. Transients - Avoid instrument and power supply transients while bias is connected to the MAAA2000G. Use shielded signal and bias cables to minimize inductive pick-up.
- D. Bias - Apply voltage to either control port A1/B2 or A2/B1 only when the other is grounded. Neither port should be allowed to "float".
- E. General Handling - It is recommended that the MAAA2000G chip be handled along the long side of the die with a sharp pair of bend tweezers. DO NOT touch the surface of the chip with fingers or tweezers.

## Mounting

The MAAA2000G is back-metallized with Pd/Ni/Au (100/1,000/10,000Å) metallization. It can be die-mounted using Au/Sn eutectic preforms or a thermally conductive epoxy. The package surface should be clean and flat before attachment.

### Eutectic Die Attach:

- A. An 80/20 Au/Sn preform is recommended with a work surface temperature of approximately 255°C and a tool temperature of 265°C. When hot 90/5 nitrogen/hydrogen gas is applied, solder temperature should be approximately 290°C.
- B. DO NOT expose the MAAA2000G to a temperature greater than 320°C for more than 20 seconds. No more than 3 seconds of scrubbing should be required for attachment.

### Epoxy Die Attach:

- A. Apply a minimum amount of epoxy and place the MAAA2000G into position. A thin epoxy fillet should be visible around the perimeter of the die.
- B. Cure epoxy per manufacturer's recommended schedule.
- C. Electrically conductive epoxy is recommended but is not required.

## Bonding

- A. Ball or wedge bond with 1.0 mil diameter pure gold wire. Thermosonic bonding with a nominal stage temperature of 150°C and a ball bonding force of 40 to 50 grams or wedge bonding force of 18 to 22 grams is recommended. Ultrasonic energy and time should be adjusted to the minimum levels necessary to achieve reliable wirebonds.
- B. Wirebonds should be started on the chip and terminated on the package. GND bonds should be as short as possible; at least three and no more than four bond wires from ground pads to package are recommended.