

## Features

- Attenuation: 1 dB Steps to 50 dB
- Single Positive Supply
- Contains Internal DC to DC Converter
- Low DC Power Consumption
- Small Footprint, JEDEC Package
- Integral TTL Driver
- 50 ohm Impedance
- Lead-Free CSP-1 Package
- 100% Matte Tin Plating over Copper
- Halogen-Free "Green" Mold Compound
- 260°C Reflow Compatible
- RoHS\* Compliant Version of AT90-1106

## Description

M/A-COM's MAAD-007080-000100 is a GaAs FET 6-bit digital attenuator with integral TTL driver. Step size is 1 dB providing a 50 dB total attenuation range. This device is in a PQFN plastic surface mount package. MAAD-007080-000100 is ideally suited for use where accuracy, fast speed, very low power consumption and low costs are required. For dual supply designs without switching noise, use MAAD-007082-000100.

## Ordering Information

| Part Number        | Package           |
|--------------------|-------------------|
| MAAD-007080-00100  | Bulk Packaging    |
| MAAD-007080-001TR  | 1000 piece reel   |
| MAAD-0007080-001TB | Sample Test Board |

Note: Reference Application Note M513 for reel size information.

\* Restrictions on Hazardous Substances, European Union Directive 2002/95/EC.

## Functional Schematic

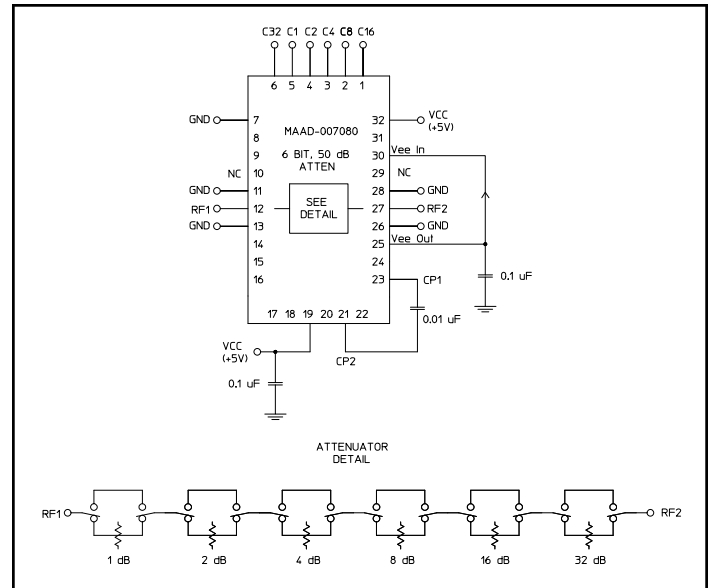

## Pin Configuration<sup>1</sup>

| Pin No. | Function        | Pin No. | Function          |
|---------|-----------------|---------|-------------------|
| 1       | C16             | 17      | NC                |
| 2       | C8              | 18      | NC                |
| 3       | C4              | 19      | +Vcc              |
| 4       | C2              | 20      | NC                |
| 5       | C1              | 21      | Cp                |
| 6       | C32             | 22      | NC                |
| 7       | GND             | 23      | Cp                |
| 8       | NC              | 24      | NC                |
| 9       | NC              | 25      | -Vee <sup>3</sup> |
| 10      | NC <sup>2</sup> | 26      | GND               |
| 11      | GND             | 27      | RF2               |
| 12      | RF1             | 28      | GND               |
| 13      | GND             | 29      | NC <sup>2</sup>   |
| 14      | NC              | 30      | -Vee <sup>3</sup> |
| 15      | NC              | 31      | NC                |
| 16      | NC              | 32      | +Vcc              |

1. The exposed pad centered on the package bottom must be connected to RF and DC ground. (For PQFN Packages)
2. Pins 10 & 29 must be isolated
3. -Vee is produced internally and requires a .1µF cap to GND. Generated noise is typical of switching DC-DC Converters.

## Digital Attenuator 50.0 dB, 6-Bit, TTL Driver, DC-2.4 GHz

Rev. V4

### Electrical Specifications: $T_A = 25^\circ\text{C}$ , $Z_0 = 50\Omega$

| Parameter   | Test Conditions  | Frequency     | Units              | Min  | Typ   | Max                              |
|---|--|---------------|--------------------|------|-------|----------------------------------|
| Insertion Loss  | —  | DC - 2.4 GHz  | dB                 | —    | 5.5   | 6.0                              |
| Attenuation Accuracy  | Individual Bits 1-2-4-8-16-32 dB<br>Any Combination of Bits 1 to 50 dB | DC - 2.4 GHz  | dB                 | —    | —     | $\pm(.3 + 5\%$ of atten setting) |
|   |  | DC - 2.4 GHz  | dB                 | —    | —     | $\pm(.5 + 8\%$ of atten setting) |
| VSWR  | Full Range   | DC - 2.4 GHz  | Ratio              | —    | 1.8:1 | 2:1                              |
| Switching Speed   | 50% Cntl to 90%/10% RF<br>10% to 90% or 90% to 10%                     | —             | ns                 | —    | 75    | —                                |
|   |  | —             | ns                 | —    | 20    | —                                |
| 1 dB Compression  | —  | 50 MHz        | dBm                | —    | +21   | —                                |
|   |  | 0.5 - 2.4 GHz | dBm                | —    | +24   | —                                |
| Input $IP_3$  | Two-tone inputs up to +5 dBm   | 50 MHz        | dB                 | —    | +35   | —                                |
|   |  | 0.5-2.4 GHz   | dB                 | —    | +48   | —                                |
| $V_{CC}$  | —  | —             | V                  | 4.75 | 5.0   | 5.25                             |
| $V_{IL}$<br>$V_{IH}$  | LOW-level input voltage<br>HIGH-level input voltage                    | —             | V                  | 0.0  | —     | 0.8                              |
|   |  | —             | V                  | 2.0  | —     | 5.0                              |
| lin (Input Leakage Current)   | $V_{in} = V_{CC}$ or GND   | —             | $\mu\text{A}$      | -1.0 | —     | 1.0                              |
| $I_{CC}^4$  | $V_{CC}$ min to max, Logic "0" or "1"                                  | —             | mA                 | —    | 6     | 10                               |
| Turn-on Current <sup>5</sup>  | For guaranteed start-up  | —             | mA                 | —    | —     | 125                              |
| $\Delta I_{CC}$<br>(Additional Supply Current<br>Per TTL Input Pin) | $V_{CC} = \text{Max}$ , $V_{cntrl} = V_{CC} - 2.1 \text{ V}$           | —             | mA                 | —    | —     | 1.0                              |
| Switching Noise   | Generated from<br>DC-DC Converter with<br>recommended capacitors       | 3.5 MHz       | dBm                | —    | -93   | —                                |
| Thermal Resistance $\theta_{jc}$                                    | —  | —             | $^\circ\text{C/W}$ | —    | 15    | —                                |

- During turn-on, the device requires an initial "Turn-on Current". Once operational,  $I_{CC}$  will drop to the specified levels.
- The DC-DC converter is guaranteed to start in 100  $\mu\text{s}$  as long as the power supplies can provide a minimum of 100 mA "Turn-on Current".

### Absolute Maximum Ratings<sup>6,7</sup>

| Parameter                                     | Absolute Maximum                                     |
|---|--|
| Max. Input Power<br>0.05 GHz<br>0.5 - 2.4 GHz | +27 dBm<br>+34 dBm                                   |
| $V_{CC}$                                      | $-0.5\text{V} \leq V_{CC} \leq +6.0\text{V}$         |
| $V_{in}^8$                                    | $-0.5\text{V} \leq V_{in} \leq V_{CC} + 0.5\text{V}$ |
| Operating Temperature                         | $-40^\circ\text{C}$ to $+85^\circ\text{C}$           |
| Storage Temperature                           | $-65^\circ\text{C}$ to $+125^\circ\text{C}$          |

- Exceeding any one or combination of these limits may cause permanent damage to this device.
- M/A-COM does not recommend sustained operation near these survivability limits.
- Standard CMOS TTL interface, latch-up will occur if logic signal is applied prior to power supply.

### Recommended PCB Configuration<sup>9</sup>

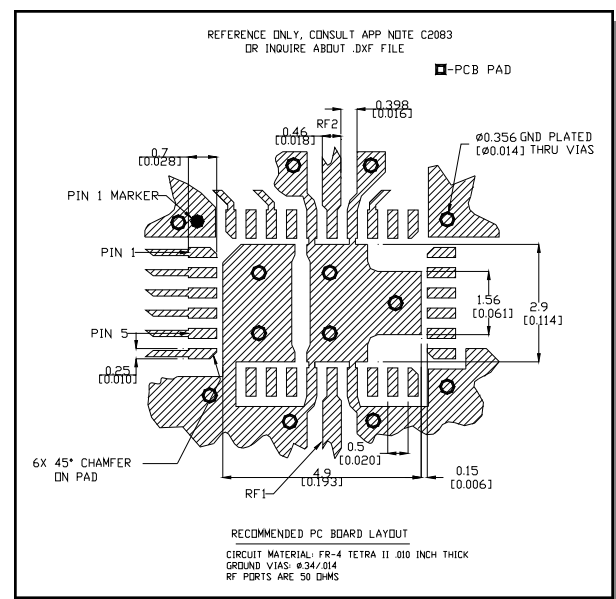

- Application Note S2083 is available on line at [www.macom.com](http://www.macom.com).

## Handling Procedures

Please observe the following precautions to avoid damage:

### Static Sensitivity

Gallium Arsenide Integrated Circuits are sensitive to electrostatic discharge (ESD) and can be damaged by static electricity. Proper ESD control techniques should be used when handling these devices.

### Moisture Sensitivity

The MSL rating for this part is defined as Level 2 per IPC/JEDEC J-STD-020. Parts shall be stored and/or baked as required for MSL Level 2 parts.

## Truth Table (Digital Attenuator)

| C32 | C16 | C8 | C4 | C2 | C1 | Attenuation     |
|-----|-----|----|----|----|----|-----------------|
| 0   | 0   | 0  | 0  | 0  | 0  | Loss, Reference |
| 0   | 0   | 0  | 0  | 0  | 1  | 1.0 dB          |
| 0   | 0   | 0  | 0  | 1  | 0  | 2.0 dB          |
| 0   | 0   | 0  | 1  | 0  | 0  | 4.0 dB          |
| 0   | 0   | 1  | 0  | 0  | 0  | 8.0 dB          |
| 0   | 1   | 0  | 0  | 0  | 0  | 16.0 dB         |
| 1   | 0   | 0  | 0  | 0  | 0  | 32.0 dB         |
| 1   | 1   | 0  | 0  | 1  | 0  | 50.0 dB         |

0 = TTL Low; 1 = TTL High

## Typical Performance Curves

### Insertion Loss

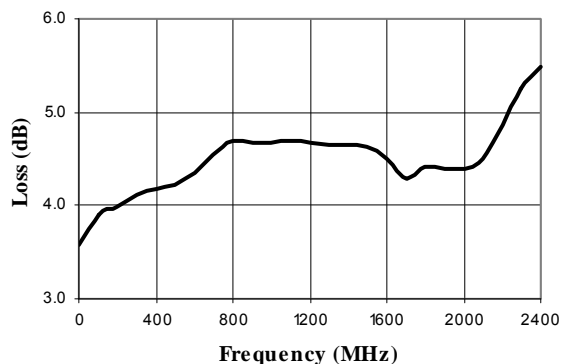

### VSWR @ Insertion Loss

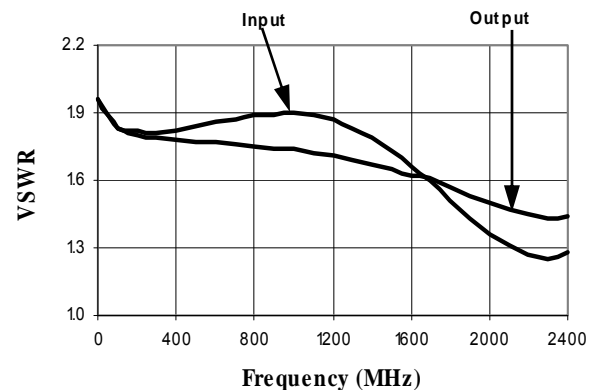

### Attenuation Error, 1 dB Bit

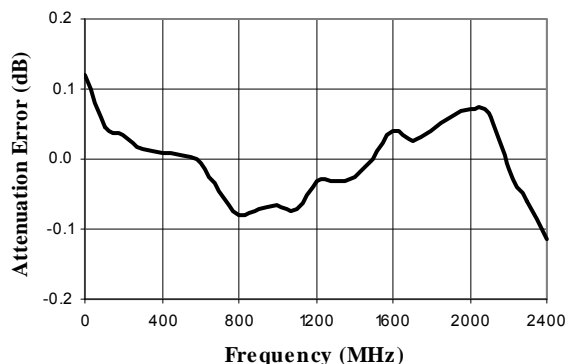

### Attenuation Error, 2 dB Bit

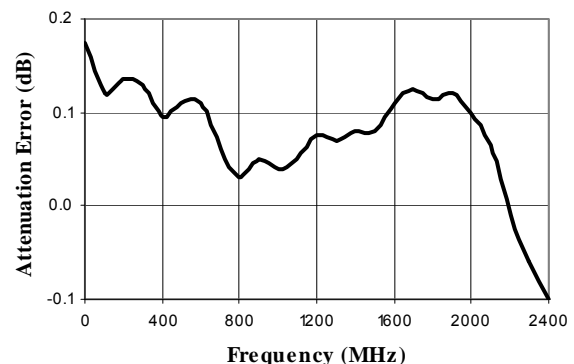

## Typical Performance Curves

Attenuation Error, 4 dB Bit

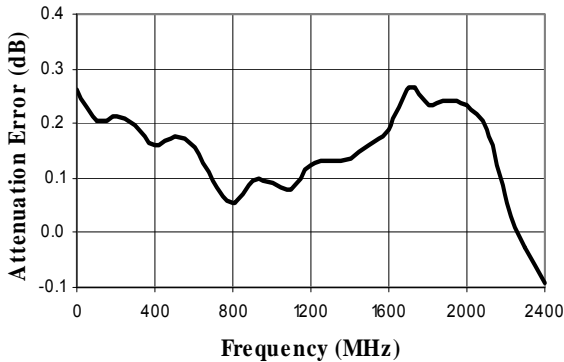

Attenuation Error, 8 dB Bit

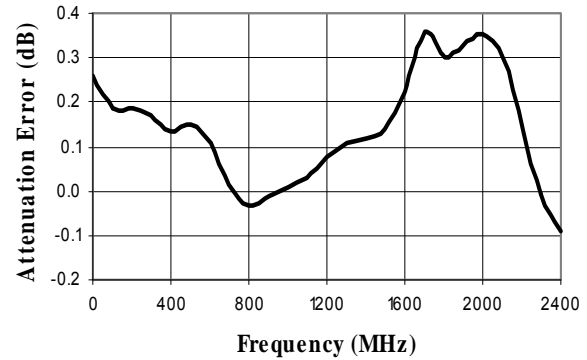

Attenuation Error, 16 dB Bit

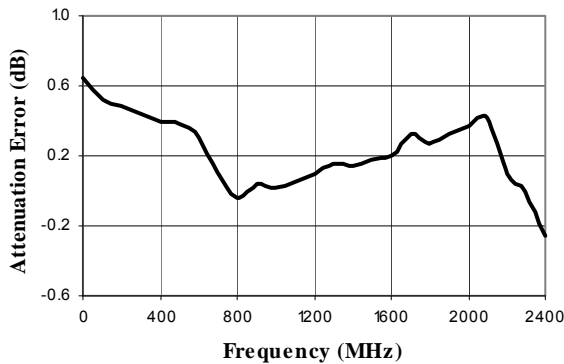

Attenuation Error, 32 dB Bit

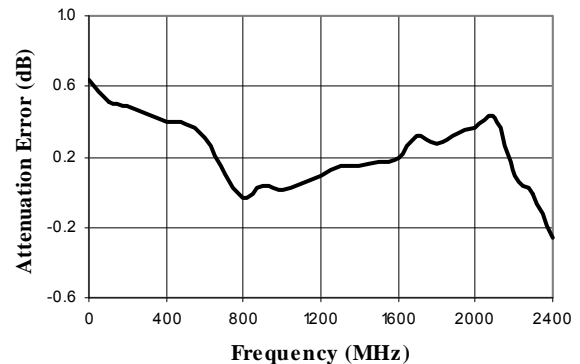

Attenuation Error, Max. Attenuation

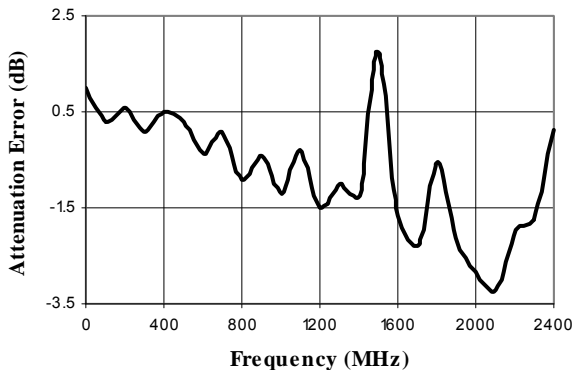

VSWR, 1 dB Bit

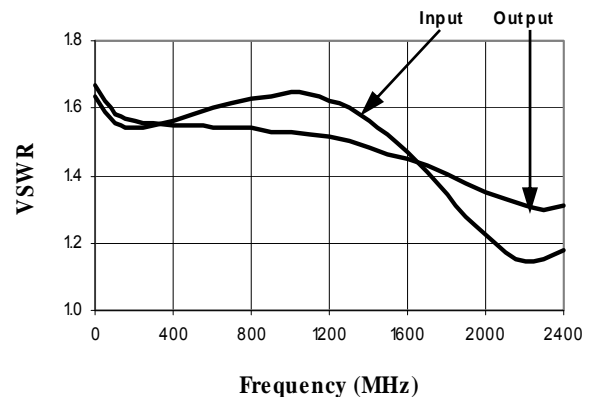

## Typical Performance Curves

VSWR, 2 dB Bit

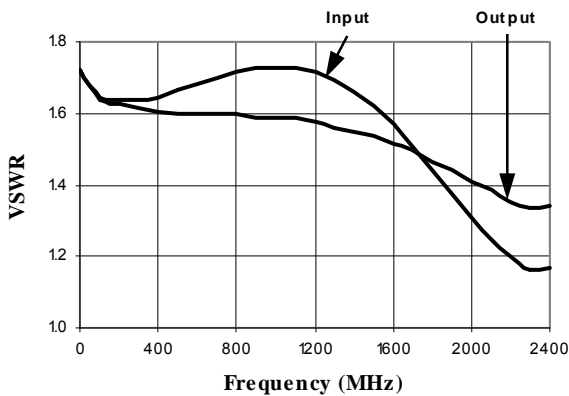

VSWR, 4 dB Bit

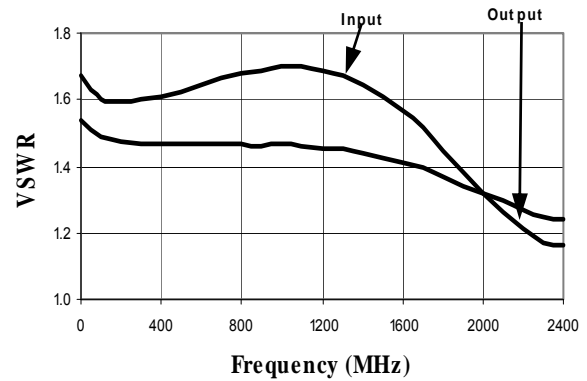

VSWR, 8 dB Bit

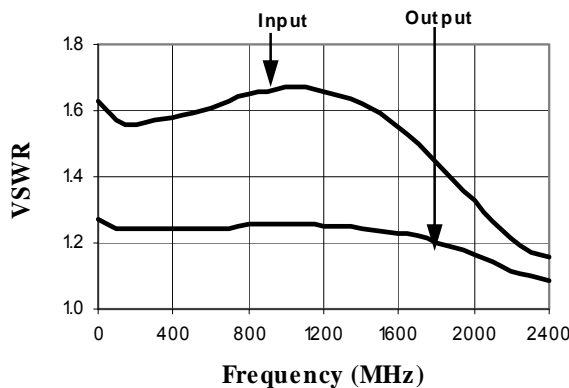

VSWR, 16 dB Bit

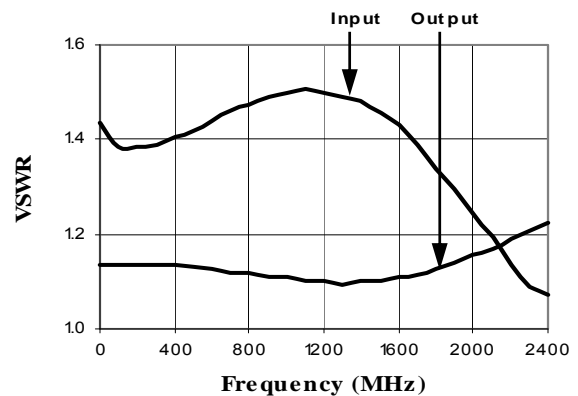

VSWR, 32 dB Bit

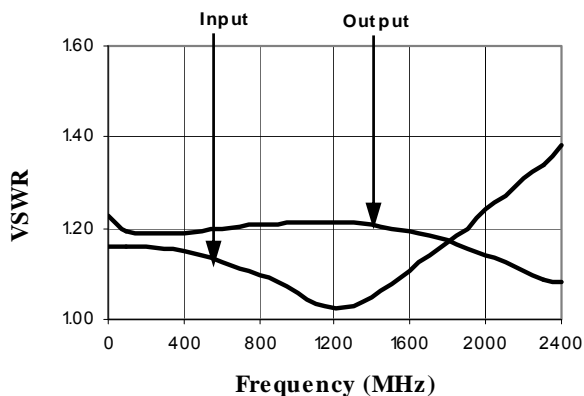

VSWR, Maximum attenuation

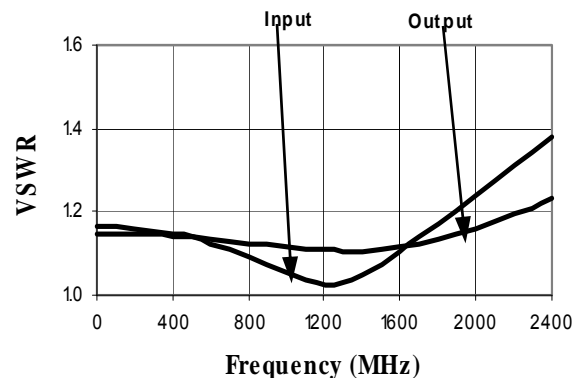

## Typical Performance Curves

**Maximum IP3 over Temperature Range and Attenuation @ 50 MHz**

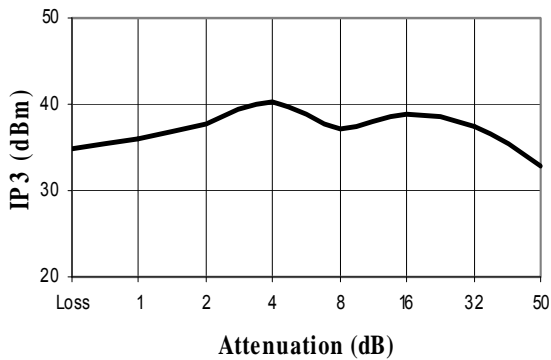

**Maximum IP3 over Temperature Range and Attenuation @ 950 MHz**

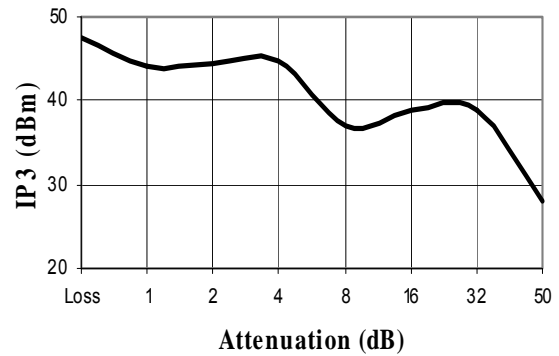

**Maximum IP3 over Temperature Range and Attenuation @ 1900 MHz**

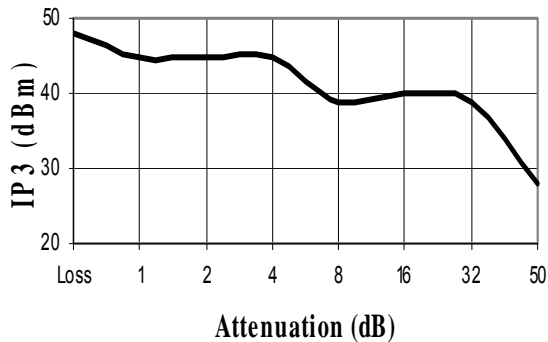

**Digital Attenuator**  
**50.0 dB, 6-Bit, TTL Driver, DC-2.4 GHz**

Rev. V4

**CSP-1, Lead-Free 4 x 6 mm, 32-lead**  
**PQFN†**

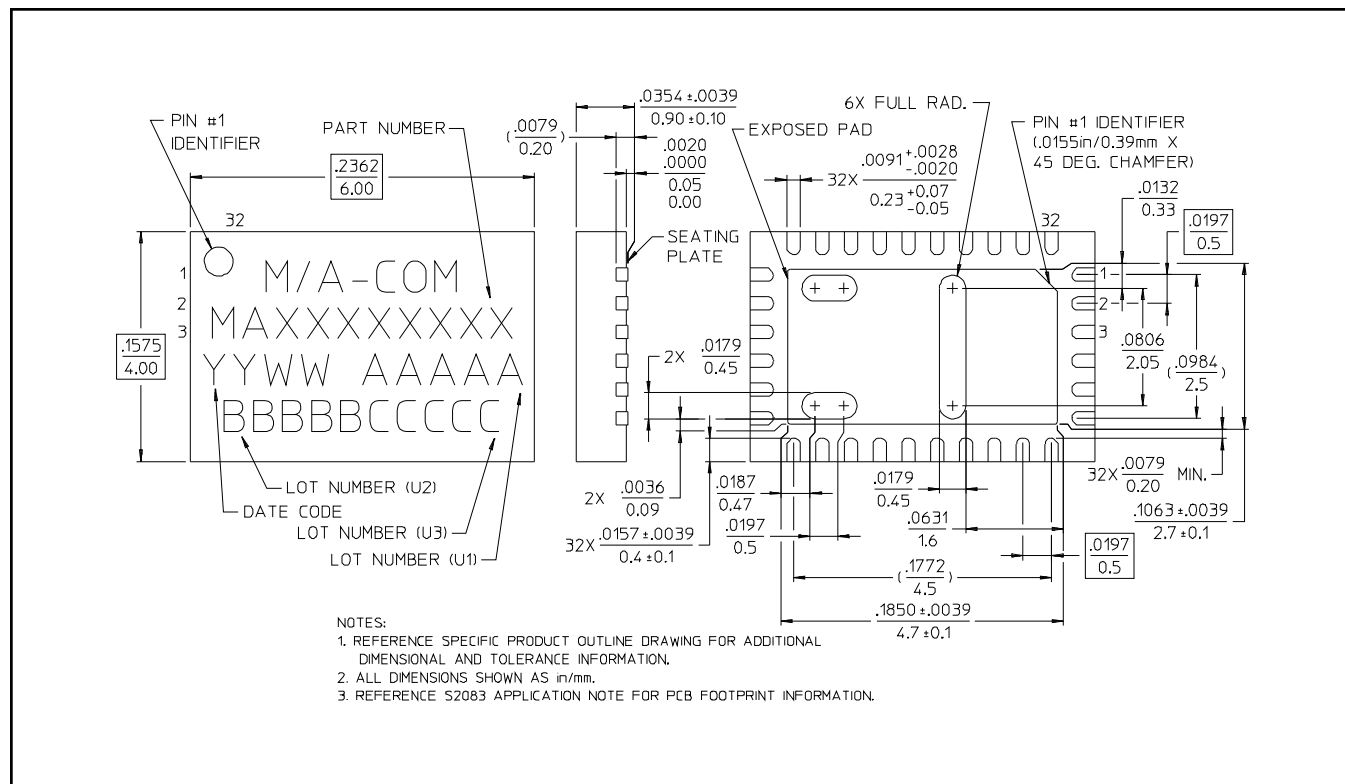

† Reference Application Note M538 for lead-free solder reflow recommendations.