

## Features

- 5 Bits, 1 dB Steps
- Excellent Accuracy
- Single Positive Control (+3 V to +5 V)
- Lead-Free QSOP-16 (SSOP-16) Package
- 100% Matte Tin Plating over Copper
- Halogen-Free "Green" Mold Compound
- 260°C Reflow Compatible
- RoHS\* Compliant Version of MAATSS0002

## Description

M/A-COM's MAADSS0010 is a 1 dB step GaAs MMIC digital attenuator with 31 dB attenuation range in a lead-free QSOP-16 (SSOP-16) package. It requires external DC blocking capacitors on the RF ports, positive supply voltage and five individual bit control voltages.

The MAADSS0010 is particularly suited where high attenuation accuracy, low insertion loss and low intermodulation products are required. Typical applications include base stations, wireless data, and wireless local loop gain level control circuits.

The MAADSS0010 is fabricated using M/A-COM's GaAs 1.0 micron process. The process features full chip passivation for increased performance and reliability.

## Functional Schematic

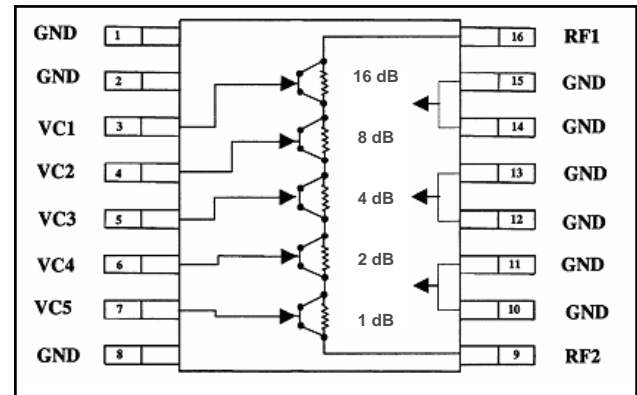

## Pin Configuration

Pin No.	Function	Pin No.	Function
1	GND	9	RF2
2	GND	10	GND
3	VC1	11	GND
4	VC2	12	GND
5	VC3	13	GND
6	VC4	14	GND
7	VC5	15	GND
8	GND	16	RF1

## Ordering Information<sup>1</sup>

Part Number	Package
MAADSS0010	Bulk Packaging
MAADSS0010TR	1000 piece reel
MAADSS0010SMB	Sample Test Board

1. Reference Application Note M513 for reel size information.

## Absolute Maximum Ratings<sup>2,3</sup>

Parameter	Absolute Maximum
Input Power	+34 dBm
Voltage	+7 V
Operating Temperature	-40°C to +85°C
Storage Temperature	-65°C to +125°C

2. Exceeding any one or combination of these limits may cause permanent damage to this device.
3. M/A-COM does not recommend sustained operation near these survivability limits.

\* Restrictions on Hazardous Substances, European Union Directive 2002/95/EC.

**Electrical Specifications:  $T_A = 25^\circ\text{C}$ ,  $Z_0 = 50 \Omega$ ,  $V_s = +5 \text{ V}$ ,  $V_c = 0 \text{ V} / 5 \text{ V}$**

Parameter	Conditions	Units	Min.	Typ.	Max.
Insertion Loss (reference state)	0.8 - 1.5 GHz	dB	—	1.8	1.9
	1.5 - 2.0 GHz	dB	—	2.2	2.3
	2.0 - 2.5 GHz	dB	—	2.7	2.9
Accuracy	0.8 - 1.5 GHz	± (0.3 dB + 4% of Attenuation)			
	1.5 - 2.0 GHz	± (0.3 dB + 3% of Attenuation)			
	2.0 - 2.5 GHz	± (0.4 dB + 3% of Attenuation)			
Step Change	0.8 - 1.5 GHz	dB	0.4	1.0	1.4
	1.5 - 2.0 GHz	dB	0.4	1.0	1.6
	2.0 - 2.5 GHz	dB	0.4	1.0	1.8
Attenuation Range	0.8 - 2.5 GHz	dB	—	31	—
VSWR	0.8 - 2.5 GHz	ratio	—	—	2.0:1
Trise, Tfall	10% to 90% RF, 90% to 10% RF	µS	—	2	—
Ton, Toff	50% Control to 10% / 90% RF	µS	—	2	—
Transients	In Band	mV	—	120	—
P1dB	+3V, 0.8 - 2.5 GHz	dBm	15	21	—
	+5V, 0.8 - 2.5 GHz	dBm	18	27	—
IP3	Two tones, Pin ≤ +5 dBm/tone	dBm	34	—	—
	+3 V, 0.8 - 2.5 GHz	dBm	43	—	—
Control Current	Vc	µA	—	—	40
	Vs	µA	—	—	200

## Truth Table <sup>4</sup>

Control Inputs					
VC5	VC4	VC3	VC2	VC1	Attenuation (dB)
1	1	1	1	1	Reference
0	1	1	1	1	1 dB
1	0	1	1	1	2 dB
1	1	0	1	1	4 dB
1	1	1	0	1	8 dB
1	1	1	1	0	16 dB

2. 0 = 0.0 V ± 0.2 V  
1 = Vs = 5.0 V ± 0.2 V

## Typical Performance Curves

**Insertion Loss**

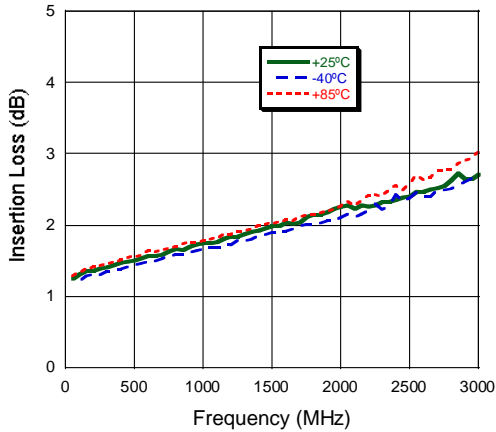

**Attenuation at Major Bits**

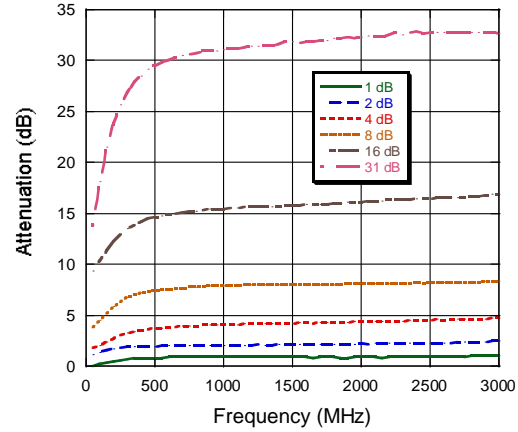

**Input Return Loss**

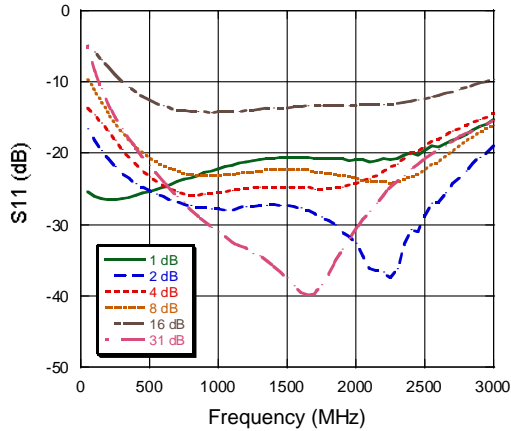

**Output Return Loss**

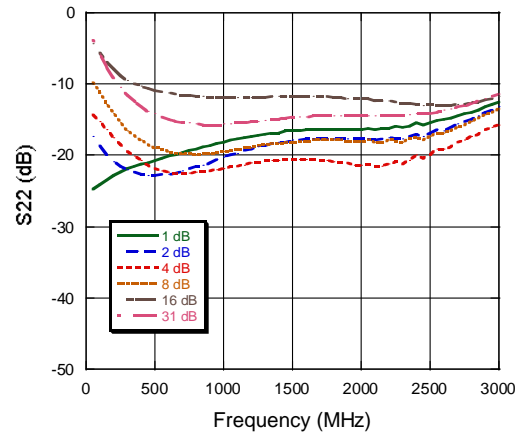

**Attenuation Accuracy**

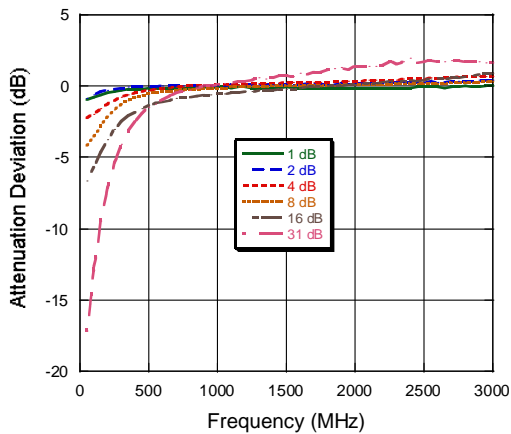

**Attenuation Accuracy vs. Setting**

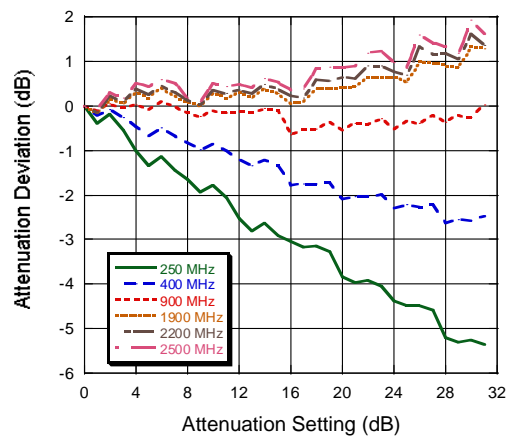

3

**ADVANCED:** Data Sheets contain information regarding a product M/A-COM Technology Solutions is considering for development. Performance is based on target specifications, simulated results, and/or prototype measurements. Commitment to develop is not guaranteed.  
**PRELIMINARY:** Data Sheets contain information regarding a product M/A-COM Technology Solutions has under development. Performance is based on engineering tests. Specifications are typical. Mechanical outline has been fixed. Engineering samples and/or test data may be available. Commitment to produce in volume is not guaranteed.

- **North America** Tel: 800.366.2266 / Fax: 978.366.2266
- **Europe** Tel: 44.1908.574.200 / Fax: 44.1908.574.300
- **Asia/Pacific** Tel: 81.44.844.8296 / Fax: 81.44.844.8298

Visit [www.macomtech.com](http://www.macomtech.com) for additional data sheets and product information.

M/A-COM Technology Solutions Inc. and its affiliates reserve the right to make changes to the product(s) or information contained herein without notice.

## Typical Performance Curves

Step Size (low frequency)

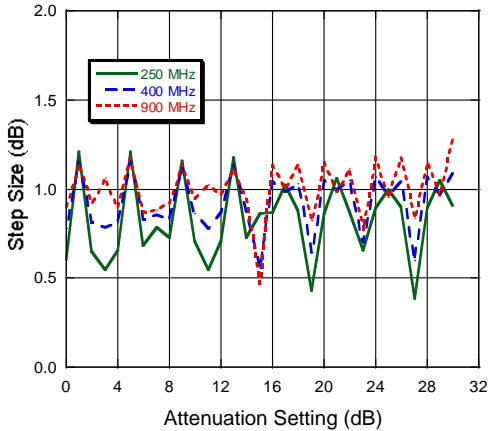

Step Size (high frequency)

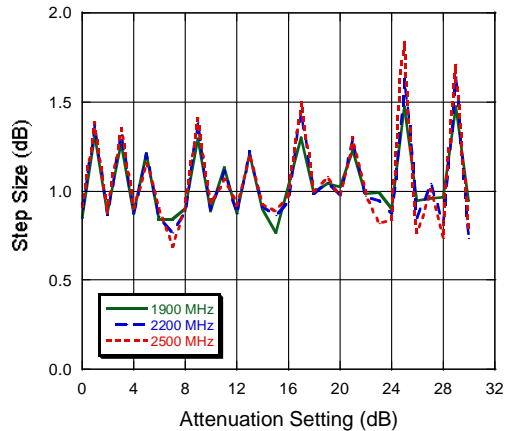

IIP3 at 3 V

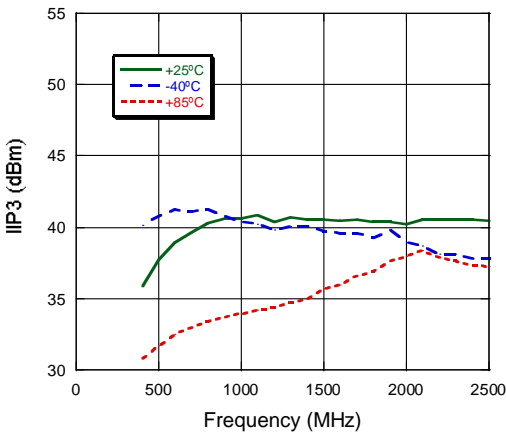

IIP3 at 5 V

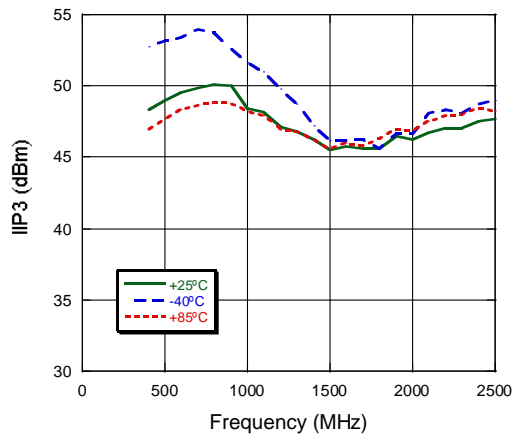

Sample Board Loss

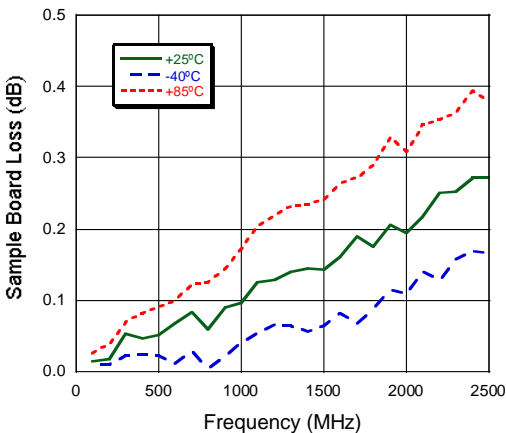

**ADVANCED:** Data Sheets contain information regarding a product M/A-COM Technology Solutions is considering for development. Performance is based on target specifications, simulated results, and/or prototype measurements. Commitment to develop is not guaranteed.  
**PRELIMINARY:** Data Sheets contain information regarding a product M/A-COM Technology Solutions has under development. Performance is based on engineering tests. Specifications are typical. Mechanical outline has been fixed. Engineering samples and/or test data may be available. Commitment to produce in volume is not guaranteed.

- **North America** Tel: 800.366.2266 / Fax: 978.366.2266
- **Europe** Tel: 44.1908.574.200 / Fax: 44.1908.574.300
- **Asia/Pacific** Tel: 81.44.844.8296 / Fax: 81.44.844.8298

Visit [www.macomtech.com](http://www.macomtech.com) for additional data sheets and product information.

M/A-COM Technology Solutions Inc. and its affiliates reserve the right to make changes to the product(s) or information contained herein without notice.

## Lead-Free QSOP-16 (SSOP-16)†

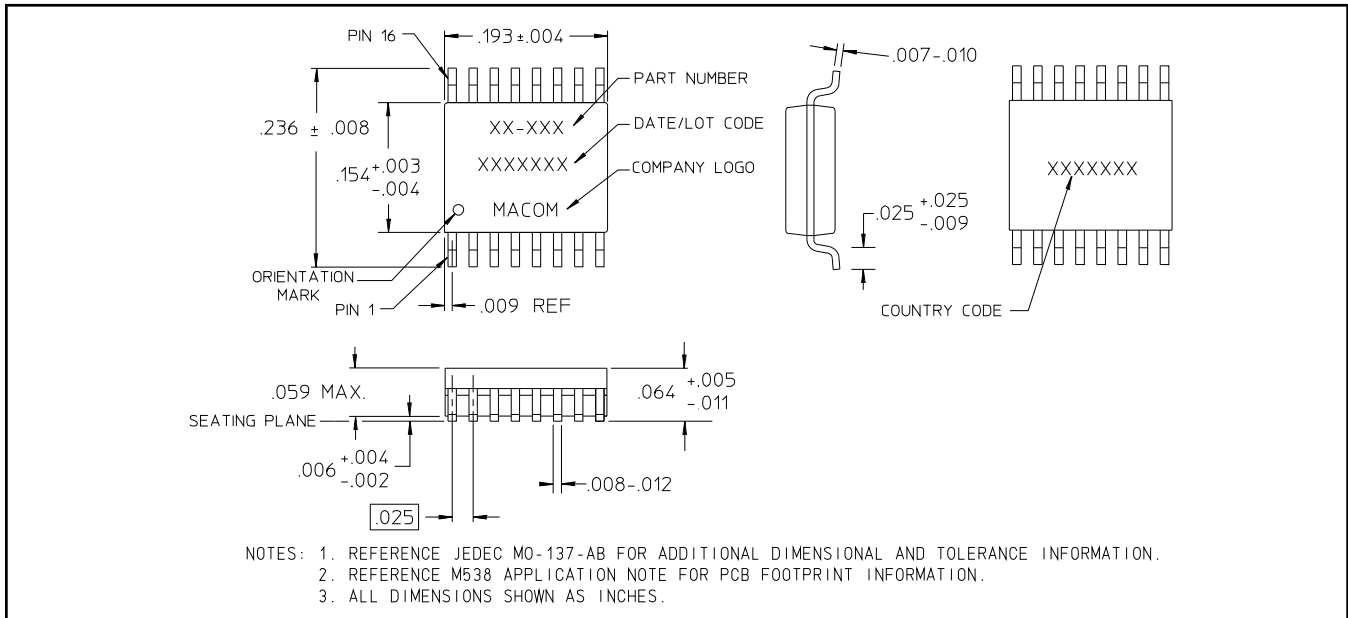

† Reference Application Note M538 for lead-free solder reflow recommendations.

## Recommended Configuration

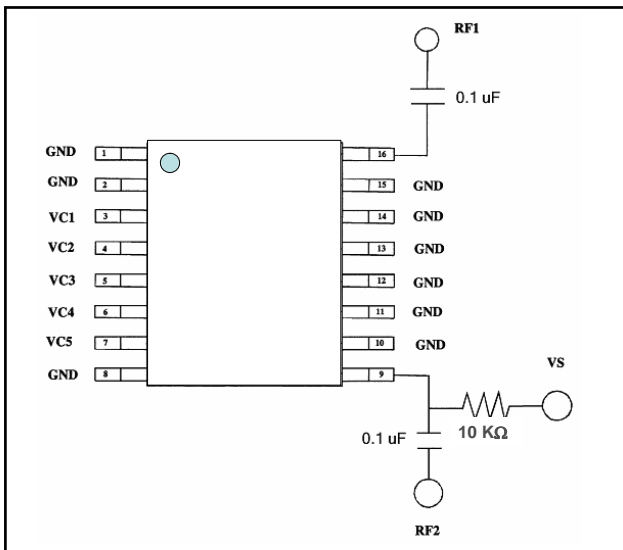

## Operating Instructions

The MAADSS0010 is designed to operate with 5 V logic levels. The difference between +3 V and +5 V operation is minimal for small signal performance. IIP3, however, is a strong function of voltage. +3 V is the minimum voltage at which the product will reliably operate.

The MAADSS0010 requires a parallel interface that allows the user to enter a 5 bit digital word. Each state increments the attenuation by 1.0 dB giving a total range of 31 dB.

The MAADSS0010 is not internally DC blocked. This means that the device requires DC blocking capacitors on the RF1 and RF2 ports. M/A-COM recommends 0.1 uF to allow for the entire frequency range to be utilized. Higher frequency applications can use smaller value capacitors as DC blocks.

For application information concerning this and other M/A-COM products, please visit our website at [www.macom.com](http://www.macom.com), where information including soldering profiles, reliability procedures, and S-parameter data can be found.