

## Features

- 20.5 dB Gain
- +8 V DC Bias
- Differential Inputs and Outputs
- Low Distortion
- Lead-Free TSSOP-16LD exposed paddle
- Halogen-Free “Green” Mold Compound
- RoHS\* Compliant and 260°C Reflow Compatible

## Description

The MAAM-010144 is a GaAs MESFET MMIC amplifier in a lead-free TSSOP-16LD exposed paddle package. The MMIC design is configured as a pair of cascode MESFET amplifiers for broadband performance. It is designed for integration in a 75 Ω push-pull, low distortion, amplifier circuit.

The device is ideally suited for use in CATV, FTTX, DBS, and HDTV applications where low noise figure and low distortion are required.

## Ordering Information <sup>1,2</sup>

Part Number	Package
MAAM-010144-000000	Bulk Packaging
MAAM-010144-TR1000	1000 Piece Reel
MAAM-010144-TR3000	3000 Piece Reel
MAAM-010144-001SMB	Sample Test Board

1. Reference Application Note M513 for reel size information.
2. All sample boards include 5 loose parts.

## Functional Schematic

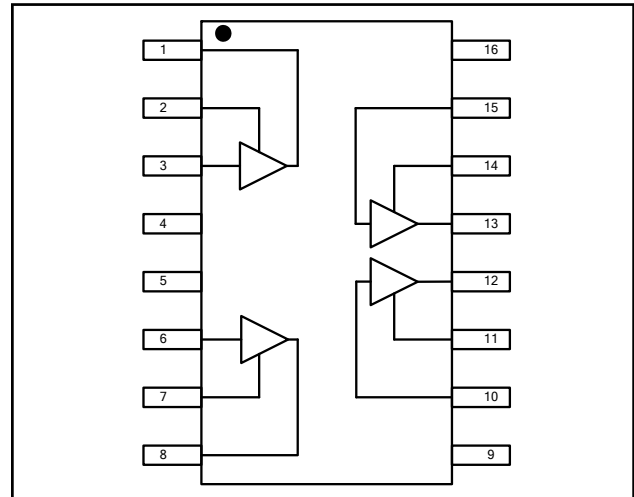

## Pin Configuration <sup>3</sup>

Pin No.	Pin Name	Description
1	OUT1+	Output 1+
2	FB1+	Feedback 1+
3	IN1+	Input 1+
4	N/C	No Connection
5	N/C	No Connection
6	IN1-	Input 1-
7	FB1-	Feedback 1-
8	OUT1-	Output 1-
9	BIAS-	DC Bias
10	IN2-	Input 2-
11	FB2-	Feedback 2-
12	OUT2-	Output 2-
13	OUT2+	Output 2+
14	FB2+	Feedback 2+
15	IN2+	Input 2+
16	BIAS+	DC Bias
Paddle <sup>4</sup>	RF and DC Ground	

3. It is recommended, but not absolutely compulsory, that all No Connections (N/C) within the IC are connected to ground on the printed circuit board.
4. The exposed pad centered on the package bottom must be connected to RF and DC ground.

\* Restrictions on Hazardous Substances, European Union Directive 2002/95/EC.

**Electrical Specifications:  $T_A = 25^\circ\text{C}$ , Freq: 50 - 1000 MHz,  $V_{DD} = +8$  Volts,  $Z_0 = 75 \Omega$ ,  
Test Circuit with M/A-COM Technology Balun MABA-009210-CT1760**

Parameter	Test Conditions	Units	Min.	Typ.	Max.
Gain	—	dB	19	20.5	23
Gain Flatness	—	dB	—	0.6	—
Noise Figure	—	dB	—	5.5	—
Input Return Loss	—	dB	—	18	—
Output Return Loss	—	dB	—	15	—
Reverse Isolation	—	dB	—	36	—
Output IP2	500 MHz, +8 dBm output	dBm	—	80	—
Output IP3	Two tones at 500 & 506 MHz, +8 dBm output/tone	dBm	41	43	—
Composite Triple Beat, CTB	77 Channels, +39 dBm V / Channel at the output	dBc	—	-70	—
Composite Second Order, CSO	77 Channels, +39 dBm V / Channel at the output	dBc	—	-70	—
Cross modulation	77 Channels, +39 dBm V / Channel at the output	dBc	—	-70	—
P1dB	500 MHz	dBm	—	26	—
$I_{DD}$	+8 Volts	mA	—	325	385

**Electrical Specifications: Frequency = 500 MHz, 256 QAM**

Parameter	Test Conditions	Units	Ref Spec <sup>5</sup>	Typical data
Adjacent channel up to 750 KHz from channel block edge	$P_{OUT} = +60$ dBmV, N=1 $P_{OUT} = +56$ dBmV, N=2 $P_{OUT} = +52$ dBmV, N=4	dBc	<-58 <-58 <-58	-65 -65 -66
Adjacent channel (750 kHz from channel block edge to 6 MHz from channel block edge)	$P_{OUT} = +60$ dBmV, N=1 $P_{OUT} = +56$ dBmV, N=2 $P_{OUT} = +52$ dBmV, N=4	dBc	<-62 <-60 <-60	-67 -64 -63
Next-adjacent channel (6 MHz from channel block edge to 18 MHz from channel block edge)	$P_{OUT} = +60$ dBmV, N=1 $P_{OUT} = +56$ dBmV, N=2 $P_{OUT} = +52$ dBmV, N=4	dBc	<-65 <-64 <-63	-75 -70 -65
Third-adjacent channel (12 MHz from channel block edge to 18 MHz from channel block edge)	$P_{OUT} = +60$ dBmV, N=1 $P_{OUT} = +56$ dBmV, N=2 $P_{OUT} = +52$ dBmV, N=4	dBc	<-73 <-70 <-65	-76 -73 -68
In each of 2N contiguous 6 MHz channels or in each of 3N contiguous 6 MHz channels coinciding with 2nd harmonic and with 3rd harmonic components respectively (up to 1000 MHz)	$P_{OUT} = +60$ dBmV, N=1, 2nd Harmonic $P_{OUT} = +60$ dBmV, N=1, 3rd Harmonic	dBc	-63 -63	-70 -65

5. Reference Specification Data-Over-Cable Service Interface Specifications, DOCSIS. Downstream RF Interface Specification, DRFI.

## Absolute Maximum Ratings<sup>6,7,8</sup>

Parameter	Absolute Maximum
RF Input Power	6 dBm
Voltage	15.0 volts
Operating Temperature	-40°C to +85°C
Junction Temperature <sup>9</sup>	+150°C
Storage Temperature	-65°C to +150°C

- Exceeding any one or combination of these limits may cause permanent damage to this device.
- M/A-COM Technology Solutions does not recommend sustained operation near these survivability limits.
- Operating at nominal conditions with  $T_J \leq +150^\circ\text{C}$  will ensure  $\text{MTTF} > 1 \times 10^6$  hours.
- Junction Temperature ( $T_J$ ) =  $T_C + \Theta_{jc} * (V * I)$   
Typical thermal resistance ( $\Theta_{jc}$ ) = 13 °C/W.
  - For  $T_C = 25^\circ\text{C}$ ,  
 $T_J = 65^\circ\text{C} @ 8 \text{ V}, 385 \text{ mA}$
  - For  $T_C = 85^\circ\text{C}$ ,  
 $T_J = 124^\circ\text{C} @ 8 \text{ V}, 375 \text{ mA}$

## Land Pattern<sup>10</sup>

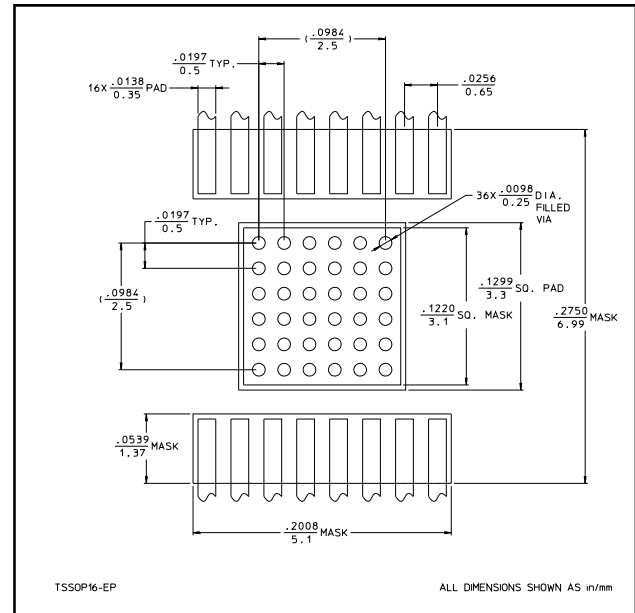

10. Vias to be plated solid copper.

## Handling Procedures

Please observe the following precautions to avoid damage:

## Static Sensitivity

Gallium Arsenide Integrated Circuits are sensitive to electrostatic discharge (ESD) and can be damaged by static electricity. Proper ESD control techniques should be used when handling these devices.

An external protection circuit using an inexpensive anti-parallel diode pair can be used to protect the IC. Please reference application note AN3028 on <http://www.macomtech.com> for further detail.

## Application Schematic

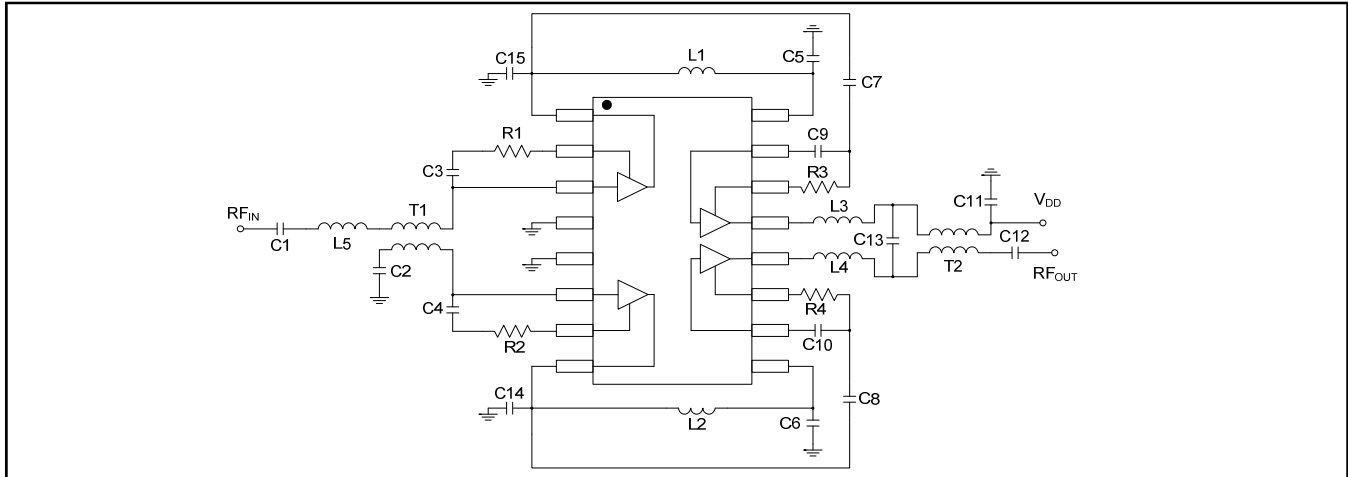

## Recommended PCB

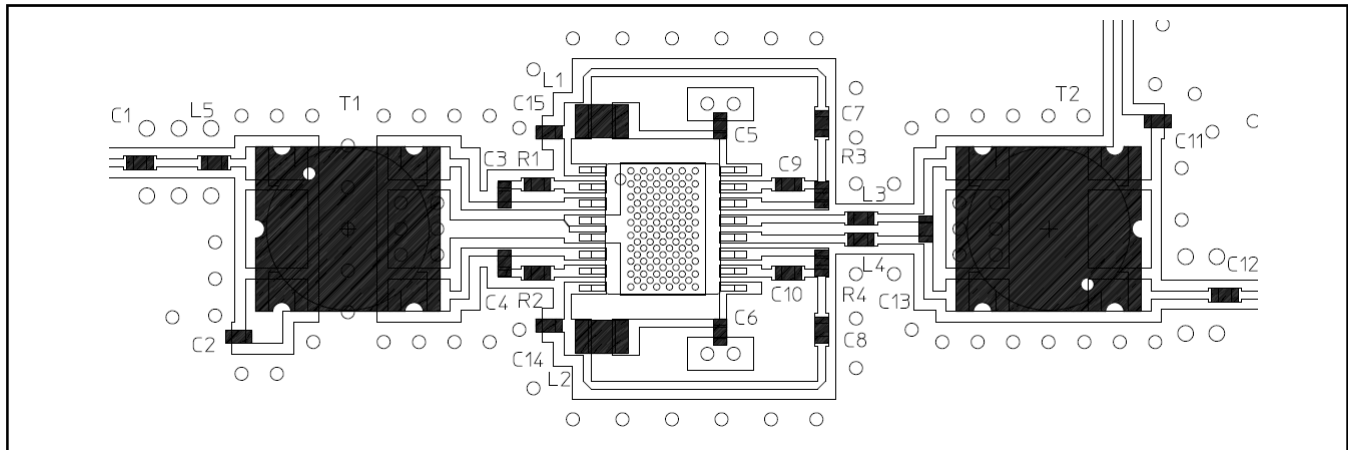

## Parts List<sup>11</sup>

Component	Value	Package
C1 - C12	0.01 $\mu$ F	0402
C13	2.7 pF	0402
C14, C15	2.0 pF	0402
R1 - R4	0 $\Omega$	0402
L1, L2	390 nH	0805
L3, L4	2.0 nH	0402
L5	5.6 nH	0402
T1, T2	1:1 Baluns	

11. The 1:1 baluns, T1 & T2 are M/A-COM Technology Solutions part number MABA-009210-CT1760

## Typical Performance Curves Over Temperature

Gain to 1 GHz

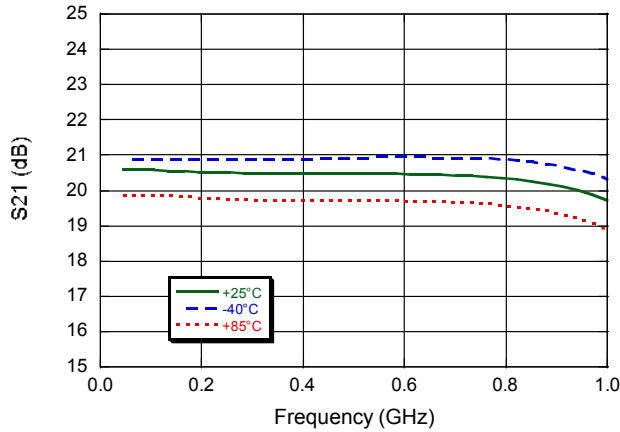

Gain to 3 GHz

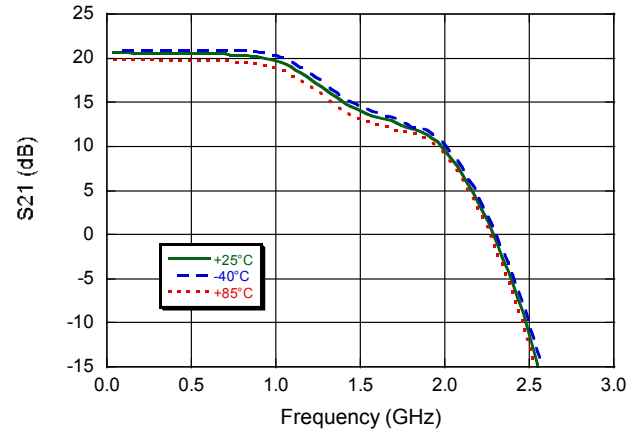

Input Return Loss

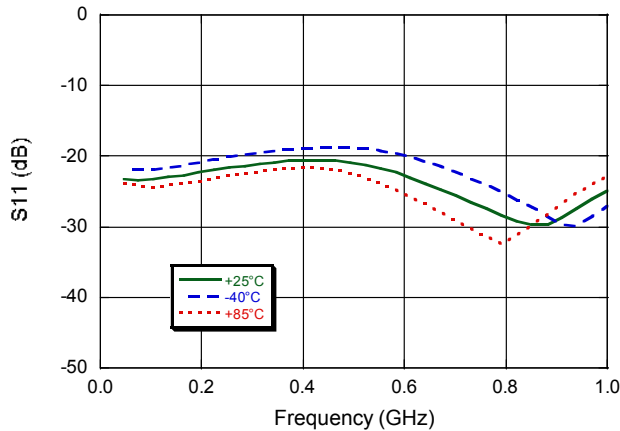

Output Return Loss

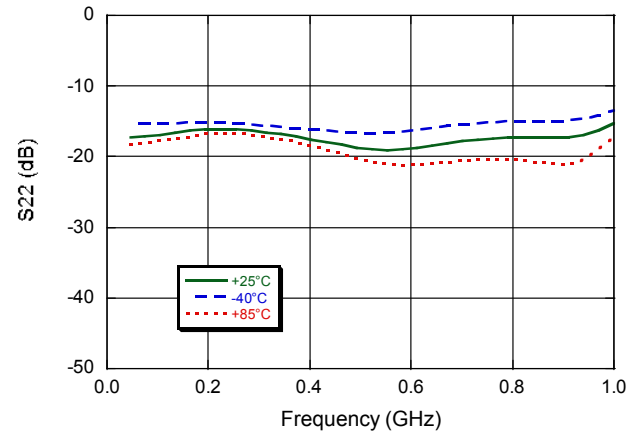

Reverse Isolation to 3 GHz

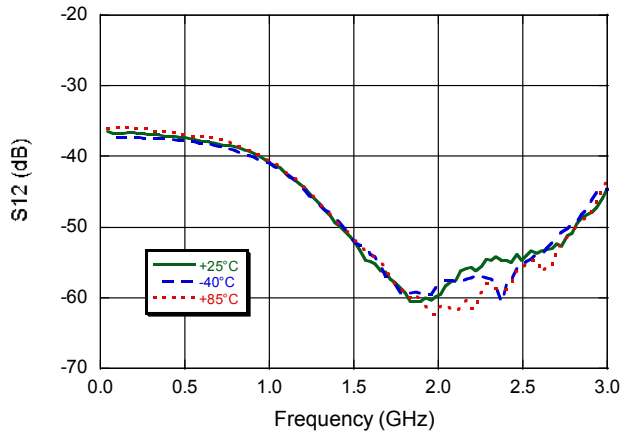

Noise Figure

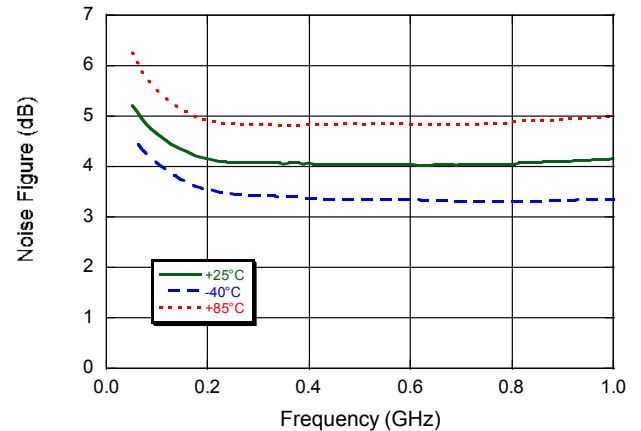

## Lead Free TSSOP 16-lead exposed paddle<sup>†</sup>

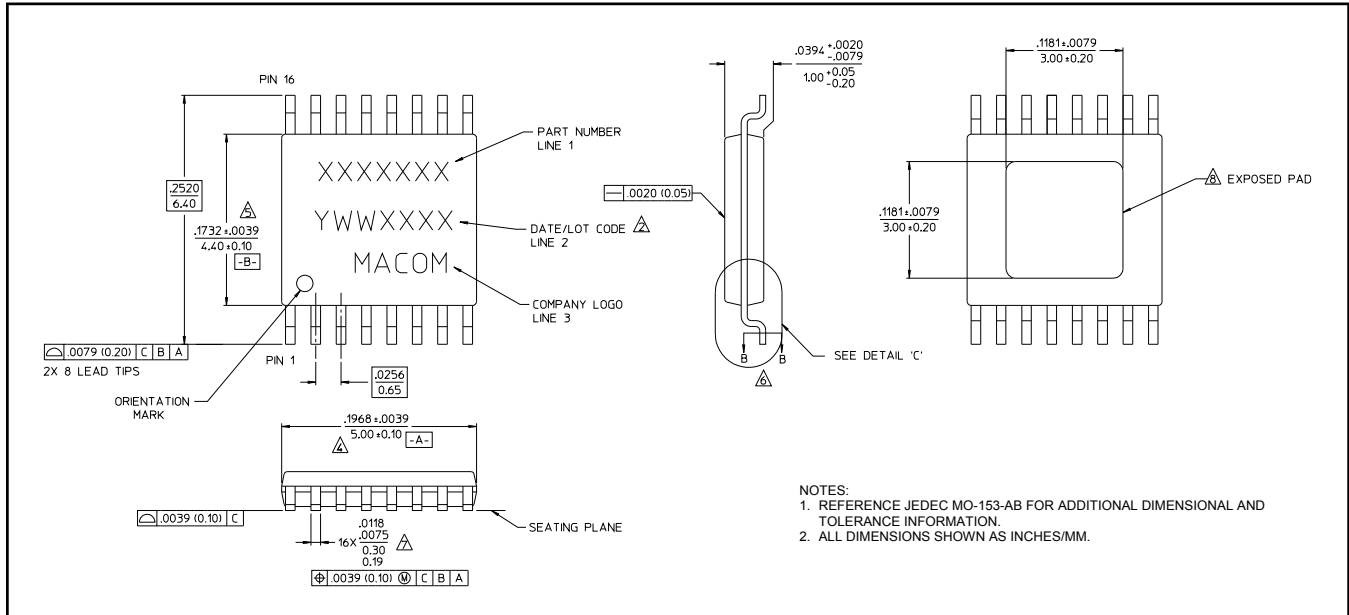

<sup>†</sup> Reference Application Note M538 for lead-free solder reflow recommendations and PCB footprint information.  
Meets JEDEC moisture sensitivity level 1 requirements.  
Plating is 100% matte tin over copper.