

PIN Diode SPDT 120 Watt Switch for 0.05 - 6.0 GHz Higher Power Applications

Rev. V2

Features

- Exceptional Broadband Performance
- Low Insertion Loss: $T_x = 0.20$ dB @ 2.7 GHz
- High Isolation: $R_x = 51$ dB @ 2.7 GHz
- High T_x RF Input Power = 120 W C.W. @ 2.7 GHz, 85°C
- Suitable for High Power LTE, TD-SCDMA, WiMAX, and Military Radio Applications
- Surface Mount 4mm PQFN Package
- RoHS* Compliant and 260°C Reflow Compatible

Description

The MASW-000936 is a SPDT high power, broadband, high linearity, PIN diode T/R switch for 0.05 – 6.0 GHz applications, including WiMAX & WiFi. The device is provided in an industry standard lead free 4mm PQFN plastic package.

This device incorporates PIN diode die fabricated with M/A-COM Technology Solutions' Low Loss, High Isolation Switching Diode processes.

Ordering Information¹

Part Number	Package
MASW-000936-14000T	Tape and Reel (1K)
MASW-000936-001SMB	Sample Board

1. Reference Application Note M513 for reel size information.

Functional Diagram (Top View)

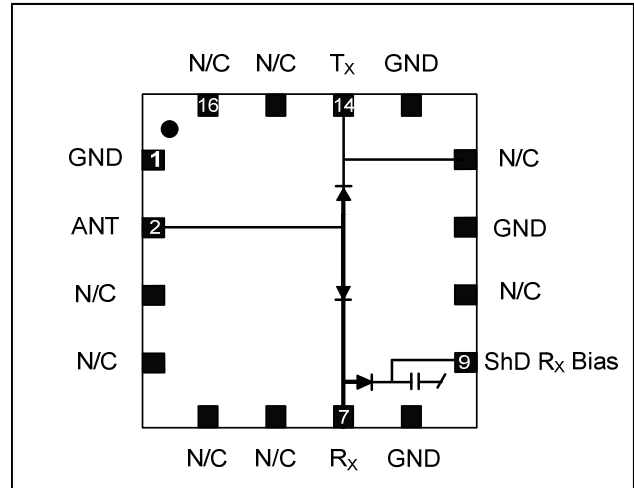

Pin Configuration²

Pin	Pin Name	Description
1	GND	Ground
2	ANT	Antenna
3	N/C	Connect to Ground
4	N/C	No Connection
5	N/C	No Connection
6	N/C	Connect to Ground
7	RX	Receive
8	GND	Ground
9	ShD RX Bias	ShD RX Bias
10	N/C	No Connection
11	GND	Ground
12 ³	N/C	Do Not Use
13	GND	Ground
14	TX	Transmit
15	N/C	Connect to Ground
16	N/C	No Connection

2. The exposed pad centered on the package bottom must be connected to RF, DC and Thermal ground.
3. Do not connect to ground or other metal trace.

* Restrictions on Hazardous Substances, European Union Directive 2002/95/EC.

1

ADVANCED: Data Sheets contain information regarding a product M/A-COM Technology Solutions is considering for development. Performance is based on target specifications, simulated results, and/or prototype measurements. Commitment to develop is not guaranteed.

PRELIMINARY: Data Sheets contain information regarding a product M/A-COM Technology Solutions has under development. Performance is based on engineering tests. Specifications are typical. Mechanical outline has been fixed. Engineering samples and/or test data may be available. Commitment to produce in volume is not guaranteed.

• **North America** Tel: 800.366.2266 • **Europe** Tel: +353.21.244.6400
 • **India** Tel: +91.80.43537383 • **China** Tel: +86.21.2407.1588
 Visit www.macomtech.com for additional data sheets and product information.

M/A-COM Technology Solutions Inc. and its affiliates reserve the right to make changes to the product(s) or information contained herein without notice.

PIN Diode SPDT 120 Watt Switch for 0.05 - 6.0 GHz Higher Power Applications

Rev. V2

Electrical Specifications⁴: Freq. = 2.0, 2.7, 3.5 GHz, T_A = 25°C, Bias = 100 mA / 28 V

Parameter	Test Conditions	Units	Min.	Typ.	Max.
Insertion Loss ⁴ Pin= 0 dBm	R _X , 0.8 GHz	dB	—	0.20	—
	T _X , 0.8 GHz			0.07	—
	R _X , 2.0 GHz			0.35	0.55
	T _X , 2.0 GHz			0.15	—
	R _X , 2.7 GHz			0.50	0.75
	T _X , 2.7 GHz			0.20	—
	R _X , 3.5 GHz			0.70	0.90
	T _X , 3.5 GHz	0.25	—		
Isolation ⁴ Pin= 0 dBm	R _X to Antenna, 2.0 GHz	dB	41	45	—
	T _X to Antenna, 2.0 GHz		—	16	
	R _X to Antenna, 2.7 GHz		40	50	
	T _X to Antenna, 2.7 GHz		—	13	
	R _X to Antenna, 3.5 GHz		33	40	
	T _X to Antenna, 3.5 GHz	—	11		
Input Return Loss ⁴ Pin= 0 dBm	R _X	dB	—	23	—
	T _X			34	
T _X Input P0.1dB	T _X to Antenna	dBm	—	>50	—
T _X IIP3 Pin = +30 dBm	F1 = 2010 MHz, F2 = 2020 MHz	dBm	—	72	—
T _X C.W. Input Power	85°C Base plate	dBm / W	—	50.8 / 120	—
	2.0 GHz			50 / 100	
	2.7 GHz			49 / 80	
	3.5 GHz				
R _X C.W. Input Power	—	dBm	—	41.5	—
		W		14	
T _X RF Switching Speed	(10-90% RF Voltage) 1 MHz Rep Rate in Modulating Mode	ns	—	200	—

4. See Bias Table

Absolute Maximum Ratings^{5,6}

@ T_A = +25 °C (unless otherwise specified)

Parameter	Absolute Maximum
Forward Current	150 mA
Reverse Voltage (RF & D.C.)	160 V
Operating Temperature	-40 °C to +85 °C
Storage Temperature	-55 °C to +150 °C
Junction Temperature	+175 °C
T _X Incident C.W. Power	50.8 dBm (120 W) ⁷ @ 2.0 GHz, 85°C

5. Exceeding these limits may cause permanent damage.

6. M/A-COM Technology Solutions does not recommend sustained operation near these survivability limits.

7. Base-plate temperature must be controlled to a constant +85°C.

Handling Procedures

Please observe the following precautions to avoid damage:

Static Sensitivity

Silicon Integrated Circuits are sensitive to electrostatic discharge (ESD) and can be damaged by static electricity. Proper ESD control techniques should be used when handling these Class 1C Human Body devices.

Bias Diagrams & Tables

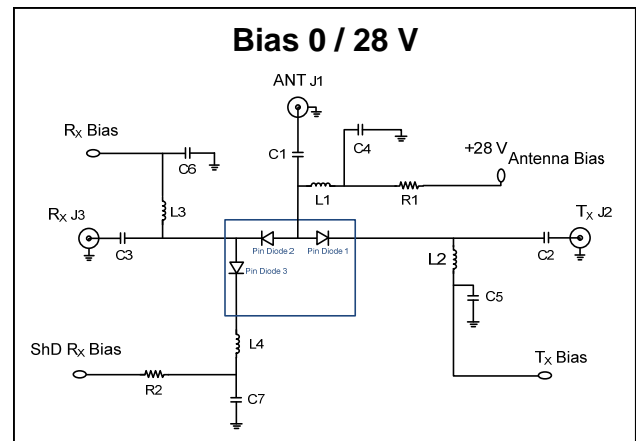
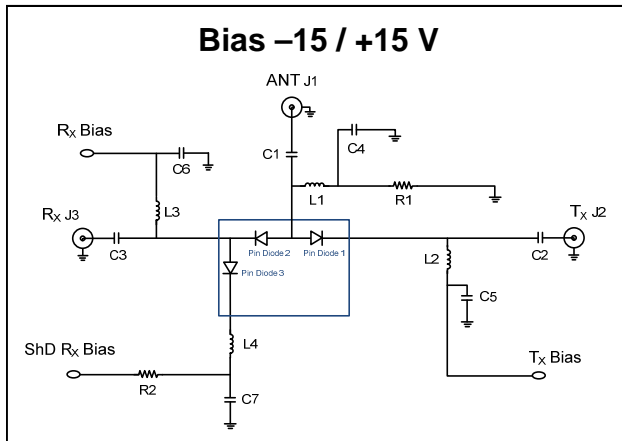

Bias -15 / +15 V

Bias Table	T _x	R _x	R _x ShdBias	ANT
Pin	Pin 14	Pin 7	Pin 9	Pin 2
T _x -ANT Isolation	(+15 V), 0 mA	(-15 V), -100 mA	GND	GND
T _x -ANT Insertion Loss	(-15 V), -100 mA	(+15 V), 100 mA	GND	GND
R _x -ANT Isolation	(-15 V), -100 mA	(+15 V), 100 mA	GND	GND
R _x -ANT Insertion Loss	(+15 V), 0 mA	(-15 V), 100 mA	GND	GND

Bias 0 / 28 V

Bias Table	T _x	R _x	R _x ShdBias	ANT
Pin	Pin 14	Pin 7	Pin 9	Pin 2
T _x -ANT Isolation	(+28 V), 0 mA	(GND), -100 mA	(+28 V), 0 mA	+28 V
T _x -ANT Insertion Loss	(GND), -100 mA	(+28 V), 100 mA	(GND), -100 mA	+28 V
R _x -ANT Isolation	(GND), -100 mA	(+28 V), 100 mA	(GND), -100 mA	+28 V
R _x -ANT Insertion Loss	(+28 V), 0 mA	(GND), -100 mA	(+28 V), 0 mA	+28 V

Typical Performance Curves (RF-probed parts), T_x (100 mA Bias Current)

Insertion Loss, T_x

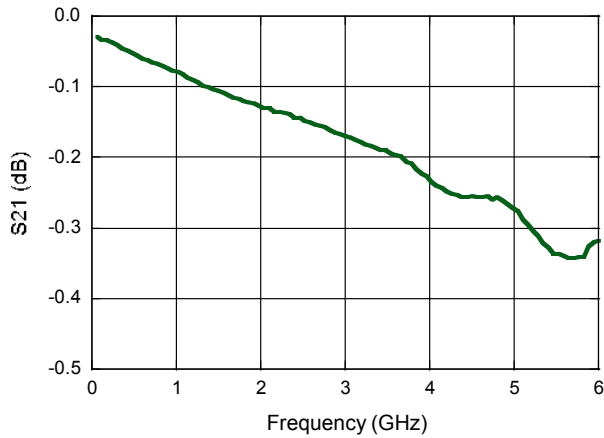

Isolation, T_x

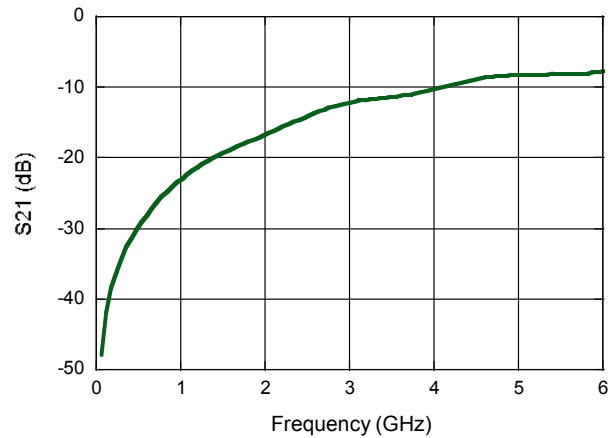

Input Return Loss, T_x

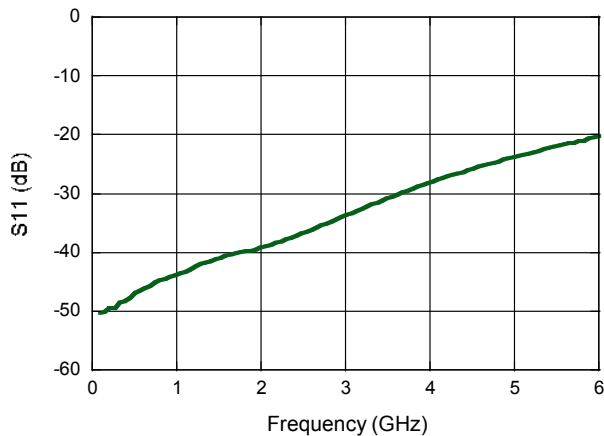

Output Return Loss, T_x

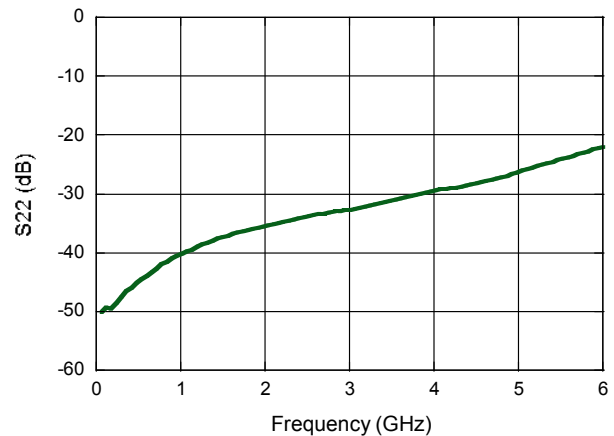

**Typical Performance Curves (RF-probed parts),
 R_x (100 mA Bias Current)**

Insertion Loss, R_x

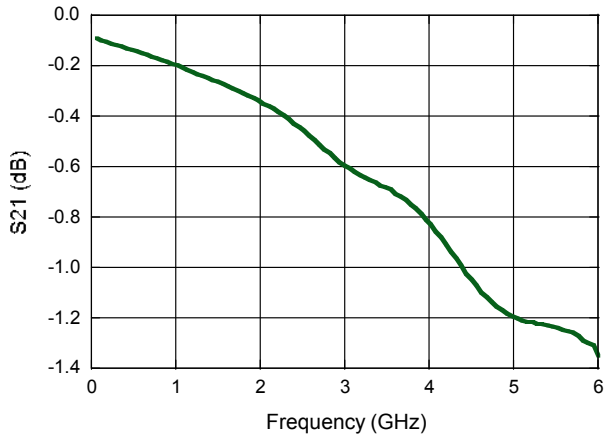

Isolation, R_x

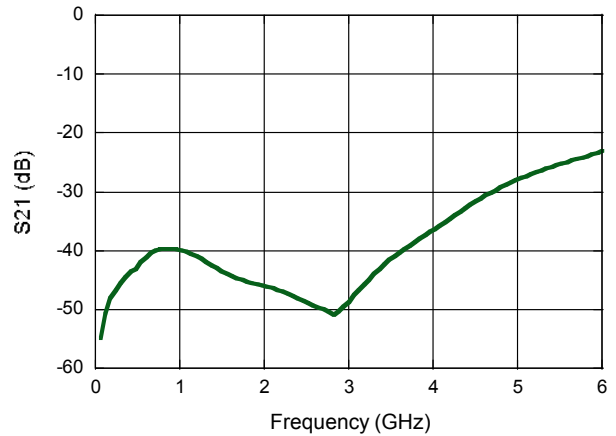

Input Return Loss, R_x

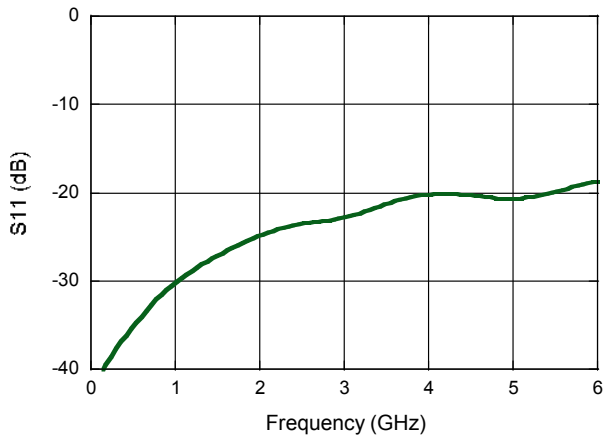

Output Return Loss, R_x

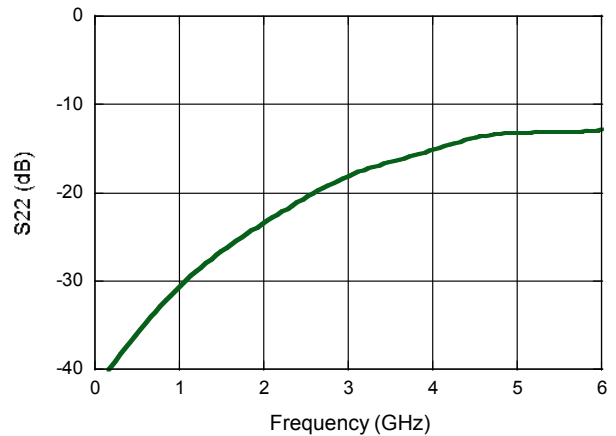

PIN Diode SPDT 120 Watt Switch for 0.05 - 6.0 GHz Higher Power Applications

Rev. V2

Application Schematic

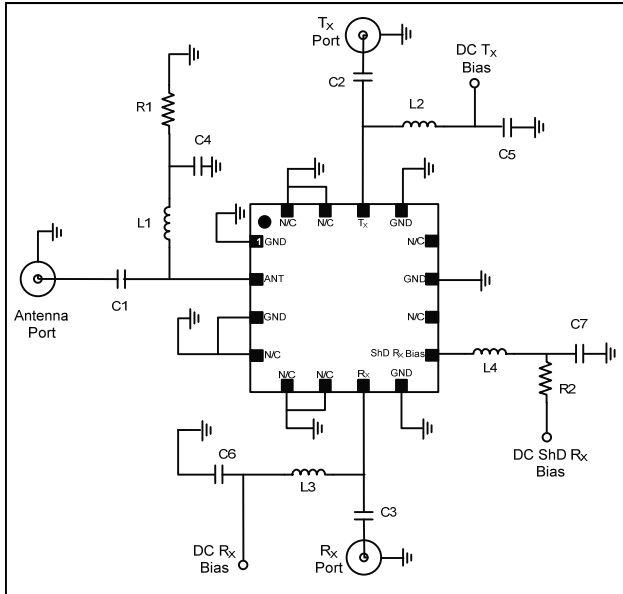

Parts List

Component	Value	Package
C1-C3	22 pF	0603
C4-C6	27 pF	0603
L1-L4	68 nH	0603
R1, R2	137 Ω	0603

PCB Footprint

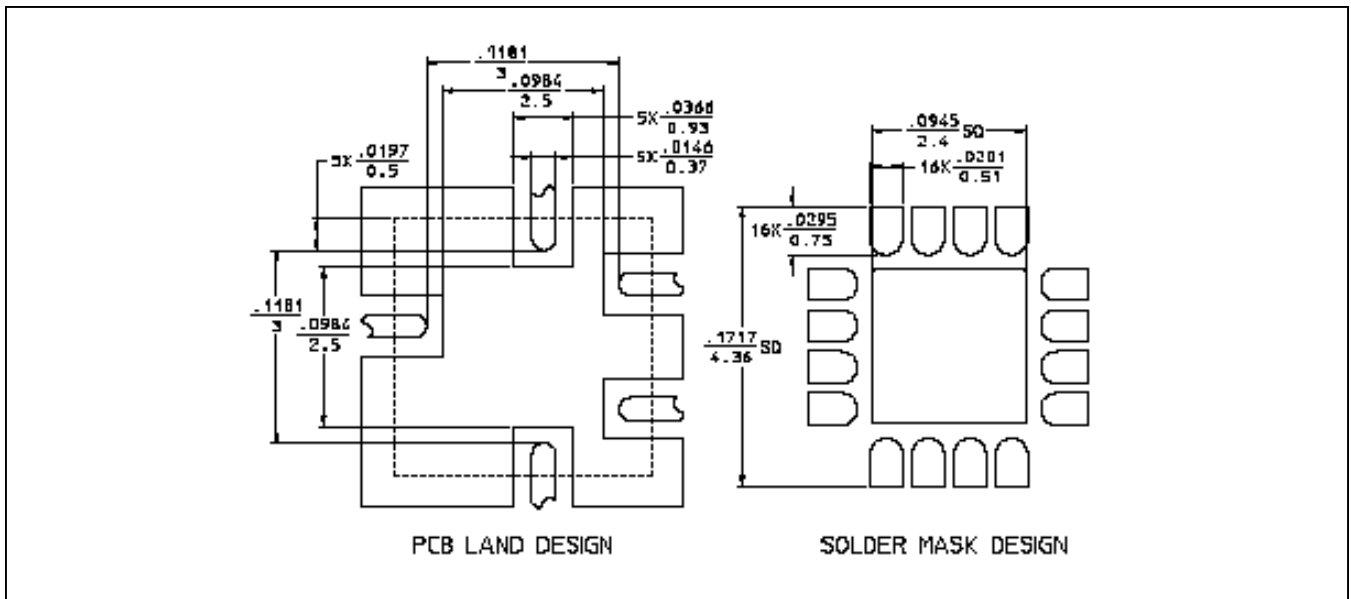

PIN Diode SPDT 120 Watt Switch for 0.05 - 6.0 GHz Higher Power Applications

Rev. V2

Lead Free 4 mm 16-Lead PQFN †

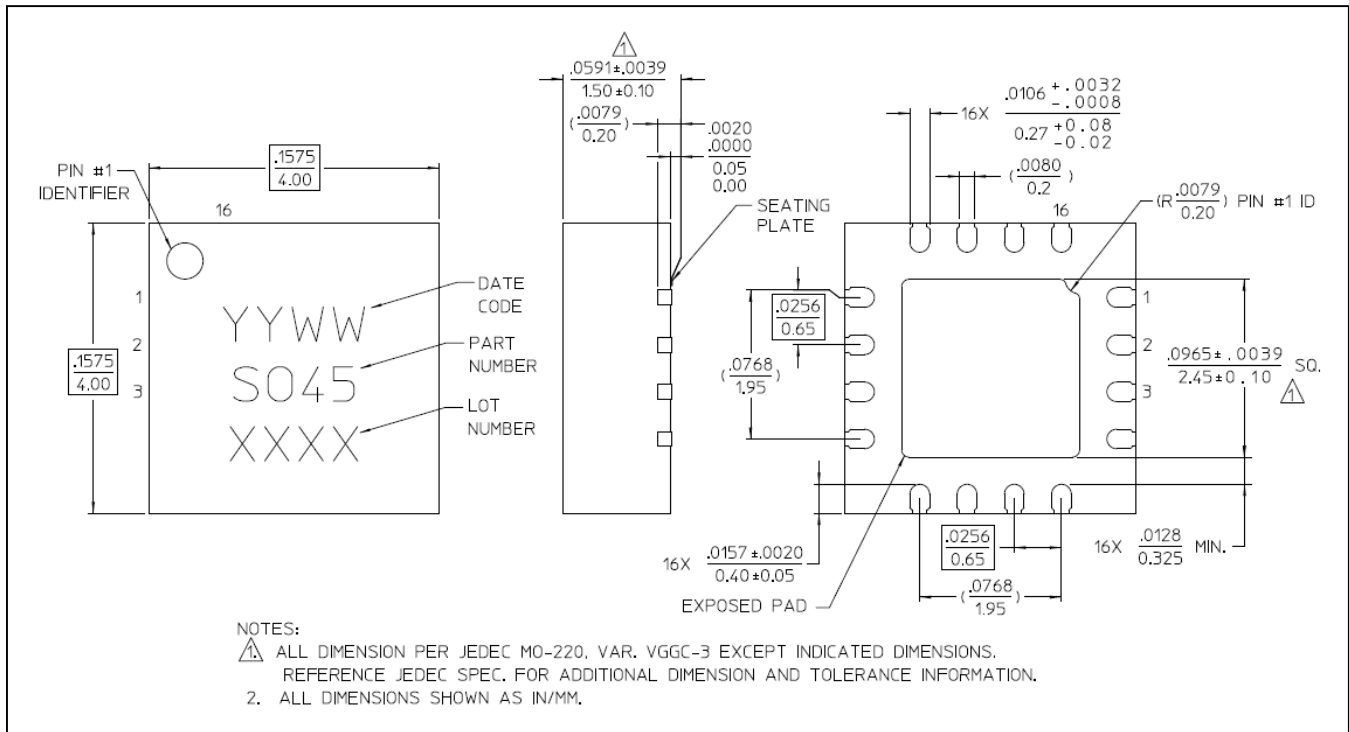

† Reference Application Note S2083 for lead-free solder reflow recommendations.
Meets JEDEC moisture sensitivity level 1 requirements.
Plating is NiPdAuAg.