

High Power GaAs DPDT Diversity Switch DC - 4.0 GHz

Rev. V1

Features

- Ideal for high power diversity switch applications including WiMax, WLAN MESH Networks, and Fixed Wireless Access
- Broadband Performance: DC - 4.0 GHz
- Low Insertion Loss: 0.8 dB @ 2.5 GHz and 1.2 dB @ 3.5 GHz
- High P1dB Compression: 39.5 dBm @ 5 V
- Fast Settling for Low Gate Lag Requirements
- Lead-Free 3 mm 12-Lead PQFN Package
- 100% Matte Tin Plating over Copper
- Halogen-Free "Green" Mold Compound
- RoHS* Compliant and 260°C Reflow Compatible

Description

M/A-COM's MASW-007587 is a broadband GaAs PHEMT MMIC diversity switch available in a lead-free 3 mm 12-lead PQFN package. The MASW-007587 is ideally suited for applications where very small size and high linear power are required.

Typical applications include 2.5 & 3.5 GHz WiMax, WLAN MESH networks, fixed wireless access, and other higher power systems. Designed for high power, this DPDT switch maintains high linearity up to 4.0 GHz.

The MASW-007587 is fabricated using a 0.5 micron gate length GaAs PHEMT process. The process features full passivation for performance and reliability.

Ordering Information ¹

Part Number	Package
MASW-007587-TR3000	3000 piece reel
MASW-007587-000SMB	Sample Test Board (Includes 5 Samples)

1. Reference Application Note M513 for reel size information.

Functional Schematic

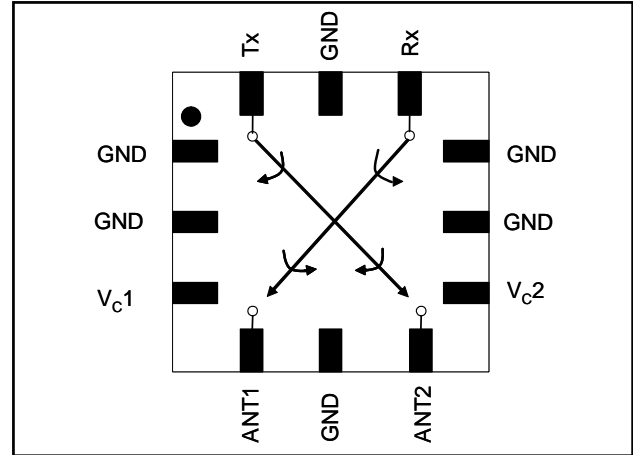

Pin Configuration

Pin No.	Pin Name	Description
1	GND	Ground
2	GND	Ground
3	V _{c1}	Control 1
4	ANT1	Antenna Port 1
5	GND	Ground
6	ANT2	Antenna Port 2
7	V _{c2}	Control 2
8	GND	Ground
9	GND	Ground
10	Rx	Receive Port
11	GND	Ground
12	Tx	Transmit Port
13	Paddle ²	RF and DC Ground

2. The exposed pad centered on the package bottom must be connected to RF and DC ground.

* Restrictions on Hazardous Substances, European Union Directive 2002/95/EC.

1

ADVANCED: Data Sheets contain information regarding a product M/A-COM Technology Solutions is considering for development. Performance is based on target specifications, simulated results, and/or prototype measurements. Commitment to develop is not guaranteed.
PRELIMINARY: Data Sheets contain information regarding a product M/A-COM Technology Solutions has under development. Performance is based on engineering tests. Specifications are typical. Mechanical outline has been fixed. Engineering samples and/or test data may be available. Commitment to produce in volume is not guaranteed.

• **North America** Tel: 800.366.2266 / Fax: 978.366.2266
 • **Europe** Tel: 44.1908.574.200 / Fax: 44.1908.574.300
 • **Asia/Pacific** Tel: 81.44.844.8296 / Fax: 81.44.844.8298
 Visit www.macomtech.com for additional data sheets and product information.

M/A-COM Technology Solutions Inc. and its affiliates reserve the right to make changes to the product(s) or information contained herein without notice.

High Power GaAs DPDT Diversity Switch DC - 4.0 GHz

Rev. V1

Electrical Specifications: $T_A = 25^\circ\text{C}$, $Z_0 = 50\Omega$, $V_C = 0\text{ V} / 3\text{ V}$, 39 pF Capacitor³

Parameter	Test Conditions	Units	Min.	Typ.	Max.
Insertion Loss ⁴	0.5 - 1 GHz	dB	—	0.6	—
	1 - 2 GHz	dB	—	0.7	—
	2 - 3 GHz	dB	—	0.8	—
	2.45 GHz	dB	—	0.8	1.2
	3 - 4 GHz	dB	—	1.2	—
Isolation (on/off or off/on) Iso @ Tx when IL from Ant 2 to Rx Iso @ Rx when IL from Ant 1 to Tx	0.5 - 1 GHz	dB	—	41.5	—
	1 - 2 GHz	dB	—	35	—
	2 - 3 GHz	dB	—	30	—
	2.45 GHz	dB	24	30	—
	3 - 4 GHz	dB	—	27	—
Isolation (on/off or off/on) Iso @ Tx when IL from Ant 1 to Rx Iso @ Rx when IL from Ant 2 to Tx	0.5 - 1 GHz	dB	—	46.5	—
	1 - 2 GHz	dB	—	43	—
	2 - 3 GHz	dB	—	38	—
	2.45 GHz	dB	29	38	—
	3 - 4 GHz	dB	—	32	—
Return Loss	0.5 - 1 GHz	dB	—	14	—
	1 - 2 GHz	dB	—	15	—
	2 - 3 GHz	dB	—	19.5	—
	3 - 4 GHz	dB	—	14	—
IP3	Two Tone, +15 dBm/Tone, 5 MHz Spacing, 2.4 GHz				
	$V_C = 3\text{ V}$	dBm	—	57.5	—
	$V_C = 5\text{ V}$	dBm	—	59	—
Input P1dB	2.4 GHz, $V_C = 3\text{ V}$	dBm	—	34	—
	2.4 GHz, $V_C = 5\text{ V}$	dBm	—	39.5	—
	2.4 GHz, $V_C = 8\text{ V}$	dBm	—	41	—
2 nd Harmonic	2.4 GHz, Pin = 15 dBm	dBc	—	-86	—
3 rd Harmonic	2.4 GHz, Pin = 15 dBm	dBc	—	-91	—
Trise, Tfall	10% to 90% RF	nS	—	64	—
	90% to 10% RF	nS	—	80	—
Ton, Toff	50% control to 90% RF and 50% control to 10% RF	nS	—	90	—
Transients	—	mV	—	5	—
Control Current	—	μA	—	5	10

3. For positive voltage control, external DC blocking capacitors are required on all RF ports.

4. Insertion loss can be optimized by varying the DC blocking capacitor value. For use above 2.5 GHz, M/A-COM recommends using smaller capacitor values. For example, use 5 pF for 3.2 GHz.

Evaluation Board for 3 mm 12-Lead PQFN

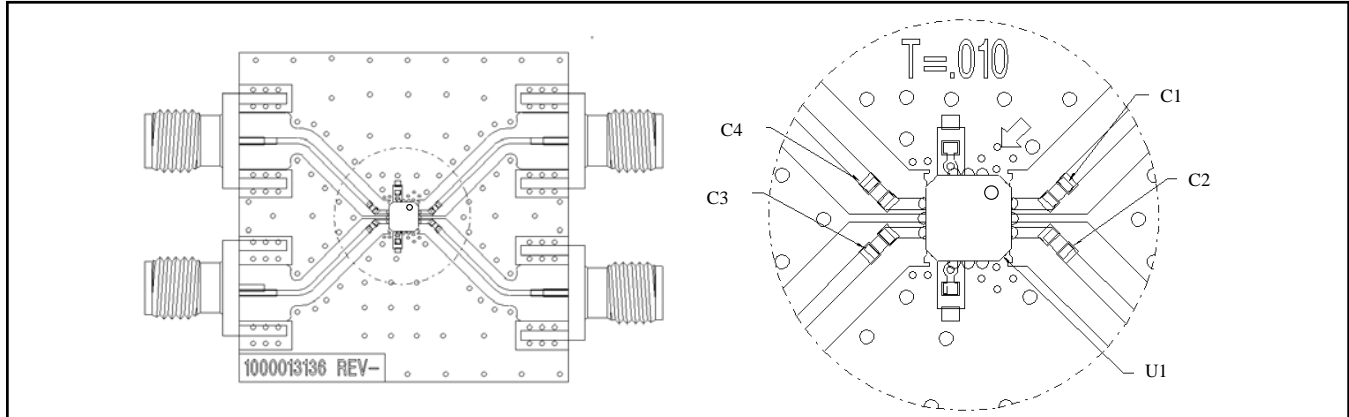

Absolute Maximum Ratings ^{5,6}

Parameter	Absolute Maximum
Input Power @ 3 V Control	+35 dBm CW
Input Power @ 5 V Control	+37 dBm CW
Voltage	≤ 8 volts
Operating Temperature	-40°C to +85°C
Storage Temperature	-65°C to +150°C

- Exceeding any one or combination of these limits may cause permanent damage to this device.
- M/A-COM does not recommend sustained operation near these survivability limits.

Application Schematic

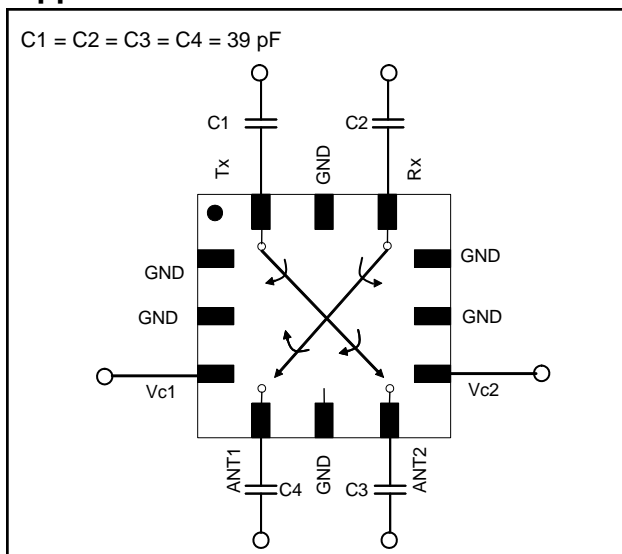

Truth Table ^{7,8}

Control V _{c1}	Control V _{c2}	ANT 1 - Rx	ANT 1 - Tx	ANT 2 - Tx	ANT 2 - Rx
1	0	On	Off	On	Off
0	1	Off	On	Off	On

- Differential voltage, V (state 1) - V (state 0), must be +2.7 V minimum and must not exceed 8.0 V.
- 1 = +2.9 V to +8 V, 0 = 0 V + 0.2 V.

Qualification

Qualified to M/A-COM specification REL-201, Process Flow -2.

Handling Procedures

Please observe the following precautions to avoid damage:

Static Sensitivity

Gallium Arsenide Integrated Circuits are sensitive to electrostatic discharge (ESD) and can be damaged by static electricity. Proper ESD control techniques should be used when handling these devices.

ADVANCED: Data Sheets contain information regarding a product M/A-COM Technology Solutions is considering for development. Performance is based on target specifications, simulated results, and/or prototype measurements. Commitment to develop is not guaranteed.
PRELIMINARY: Data Sheets contain information regarding a product M/A-COM Technology Solutions has under development. Performance is based on engineering tests. Specifications are typical. Mechanical outline has been fixed. Engineering samples and/or test data may be available. Commitment to produce in volume is not guaranteed.

- North America** Tel: 800.366.2266 / Fax: 978.366.2266
- Europe** Tel: 44.1908.574.200 / Fax: 44.1908.574.300
- Asia/Pacific** Tel: 81.44.844.8296 / Fax: 81.44.844.8298

Visit www.macomtech.com for additional data sheets and product information.

M/A-COM Technology Solutions Inc. and its affiliates reserve the right to make changes to the product(s) or information contained herein without notice.

Typical Performance Curves

Insertion Loss, 4 pF Capacitors

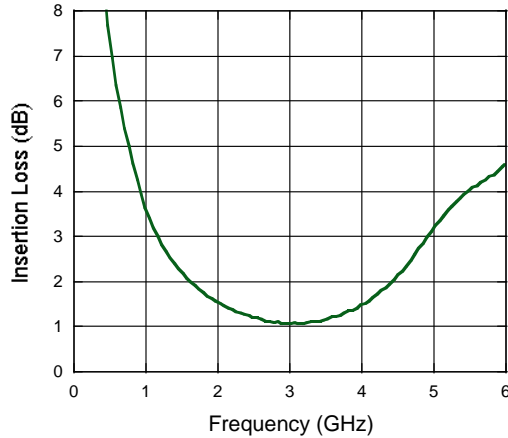

Insertion Loss, 39 pF Capacitors

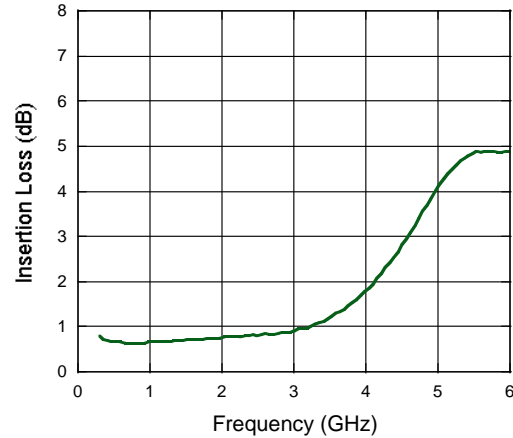

Isolation, 4 pF Capacitors

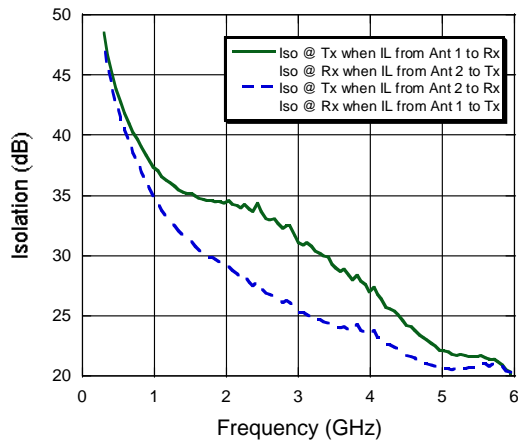

Isolation, 39 pF Capacitors

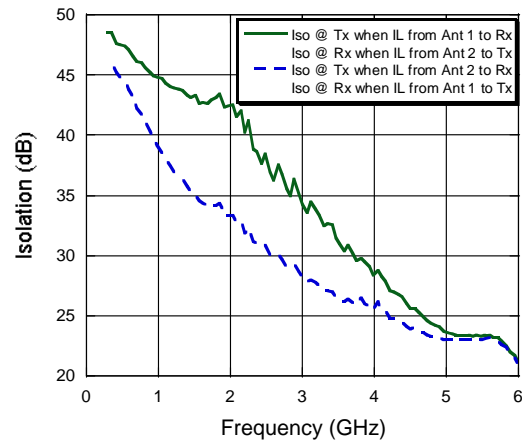

S11,

S11,

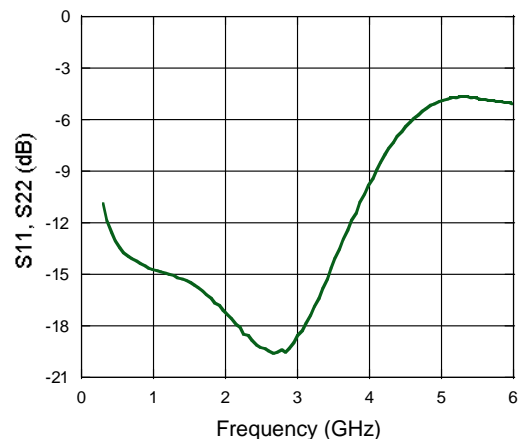
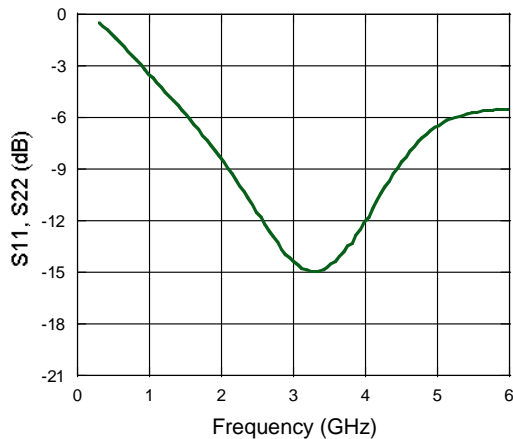

ADVANCED: Data Sheets contain information regarding a product M/A-COM Technology Solutions is considering for development. Performance is based on target specifications, simulated results, and/or prototype measurements. Commitment to develop is not guaranteed.

PRELIMINARY: Data Sheets contain information regarding a product M/A-COM Technology Solutions has under development. Performance is based on engineering tests. Specifications are typical. Mechanical outline has been fixed. Engineering samples and/or test data may be available. Commitment to produce in volume is not guaranteed.

- **North America** Tel: 800.366.2266 / Fax: 978.366.2266
- **Europe** Tel: 44.1908.574.200 / Fax: 44.1908.574.300
- **Asia/Pacific** Tel: 81.44.844.8296 / Fax: 81.44.844.8298

Visit www.macomtech.com for additional data sheets and product information.

M/A-COM Technology Solutions Inc. and its affiliates reserve the right to make changes to the product(s) or information contained herein without notice.

High Power GaAs DPDT Diversity Switch DC - 4.0 GHz

Rev. V1

Lead-Free 3 mm 12-Lead PQFN[†]

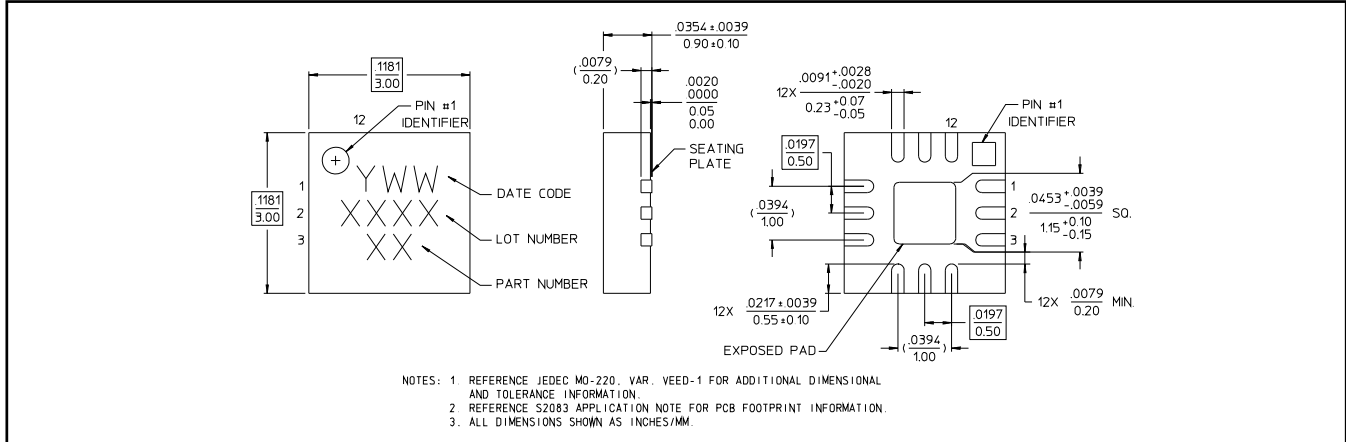

[†] Reference Application Note M538 for lead-free solder reflow recommendations.