

## Features

- Low Voltage Operation: 2.5V
- Low Insertion Loss: 0.3 dB at 1 GHz
- 0.5 micron GaAs PHEMT Process
- Lead-Free 2 mm 8-Lead PDFN Package
- 100% Matte Tin Plating over Copper
- Halogen-Free "Green" Mold Compound
- 260°C Reflow Compatible
- RoHS\* Compliant version of MASWSS0028

## Description

M/A-COM's MASW-008330 is a GaAs PHEMT MMIC single pole three throw (SP3T) switch in a lead-free 2 mm 8-lead PDFN package. The MASW-008330 is ideally suited for applications where low control voltage, low insertion loss, high isolation, small size and low cost are required.

Typical applications are for filter and antenna switching in handset systems that connect separate receive functions to a common antenna, as well as other related handset and general purpose applications. This part can be used in all systems operating up to 3 GHz requiring low control voltage.

The MASW-008330 is fabricated using a 0.5 micron gate length GaAs PHEMT process. The process features full passivation for performance and reliability.

## Ordering Information<sup>1</sup>

Part Number	Package
MASW-008330-TR3000	3000 piece reel
MASW-008330-TR3000	3000 piece reel
MASW-008330-001SMB	Sample Test Board (Includes 5 samples)

1. Reference Application Note M513 for reel size information.

## Truth Table<sup>2</sup>

V1	V2	V3	RFC - RF1	RFC - RF2	RFC - RF3
0	1	0	On	Off	Off
1	0	0	Off	On	Off
0	0	1	Off	Off	On

2. 0 = 0 V ± 0.2 V, 1 = +2.5 V to +5 V.

\* Restrictions on Hazardous Substances, European Union Directive 2002/95/EC.

## Functional Schematic

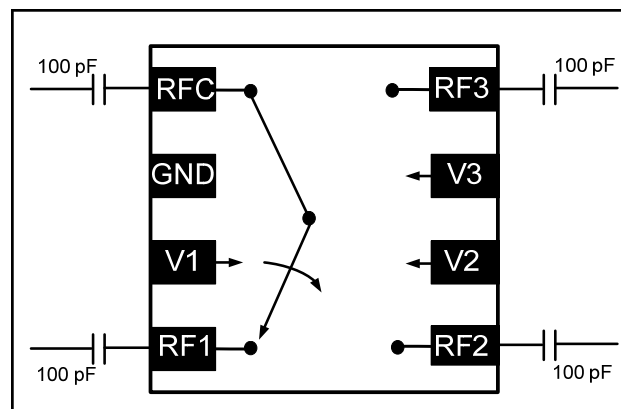

## Pin Configuration

Pin No.	Function	Description
1	RFC	RF In/Out
2	GND	RF Ground
3	V1	Control 1
4	RF1	RF In/Out
5	RF2	RF In/Out
6	V2	Control 2
7	V3	Control 3
8	RF3	RF In/Out

## Absolute Maximum Ratings<sup>3,4</sup>

Parameter	Absolute Maximum
Max Input Power (0.5 - 3 GHz, 2.5V Control)	+32 dBm
Voltage	±8.5 volts
Operating Temperature	-40°C to +85°C
Storage Temperature	-65°C to +150°C

3. Exceeding any one or combination of these limits may cause permanent damage to this device.

4. M/A-COM does not recommend sustained operation near these survivability limits.

**ADVANCED:** Data Sheets contain information regarding a product M/A-COM Technology Solutions is considering for development. Performance is based on target specifications, simulated results, and/or prototype measurements. Commitment to develop is not guaranteed.

**PRELIMINARY:** Data Sheets contain information regarding a product M/A-COM Technology Solutions has under development. Performance is based on engineering tests. Specifications are typical. Mechanical outline has been fixed. Engineering samples and/or test data may be available. Commitment to produce in volume is not guaranteed.

• **North America** Tel: 800.366.2266 / Fax: 978.366.2266

• **Europe** Tel: 44.1908.574.200 / Fax: 44.1908.574.300

• **Asia/Pacific** Tel: 81.44.844.8296 / Fax: 81.44.844.8298

Visit [www.macomtech.com](http://www.macomtech.com) for additional data sheets and product information.

M/A-COM Technology Solutions Inc. and its affiliates reserve the right to make changes to the product(s) or information contained herein without notice.

**Electrical Specifications:  $T_A = 25^\circ\text{C}$ ,  $V_C = 0\text{ V} / 2.5\text{ V}$ ,  $Z_0 = 50\ \Omega$ <sup>5</sup>**

Parameter	Test Conditions	Units	Min.	Typ.	Max.
Insertion Loss <sup>6</sup>	DC - 1 GHz	dB	—	0.3	0.4
	1 - 2 GHz	dB	—	0.5	0.6
	2 - 3 GHz	dB	—	0.75	1.0
Isolation	DC - 1 GHz	dB	19	24	—
	1 - 2 GHz	dB	13	18	—
	2 - 3 GHz	dB	10	14	—
Return Loss	DC - 2.5 GHz 2.5 - 3 GHz	dB dB	— —	25 20	— —
IP3	Two Tone, +0 dBm/tone, 1 MHz Spacing, > 50 MHz	dBm	—	50	—
P1dB	—	dBm	—	21	—
Trise, Tfall	10% to 90% RF, 90% to 10% RF	nS	—	13	—
Ton, Toff	50% control to 90% RF and 50% control to 10% RF	nS	—	15	—
Transients	In Band	mV	—	30	—
Control Current	$ V_C  = 2.5\text{V}$	$\mu\text{A}$	—	1	10

5. External DC blocking capacitors are required on all RF ports.

6. Insertion loss can be optimized by varying the DC blocking capacitor value, e.g. 100 pF for 100 - 500 MHz, 39 pF for 0.5 - 3 GHz.

**Lead Free 2 mm 8-lead PDFN<sup>†</sup>**

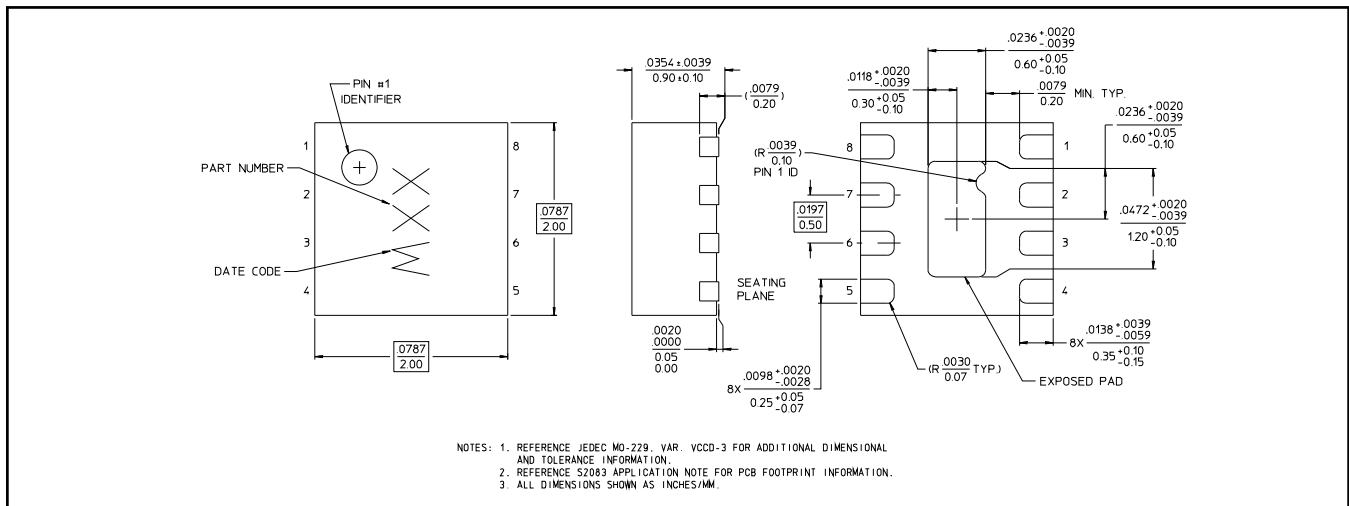

<sup>†</sup> Reference Application Note M538 for lead-free solder reflow recommendations.  
Meets JEDEC moisture sensitivity level 1 requirements.

## Typical Performance Curves vs. Frequency and Temperature

### Isolation

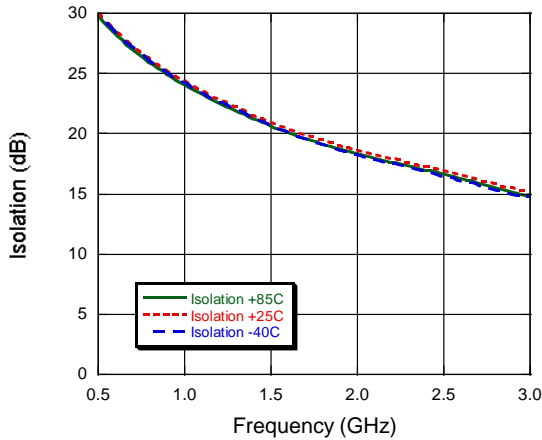

### Insertion Loss

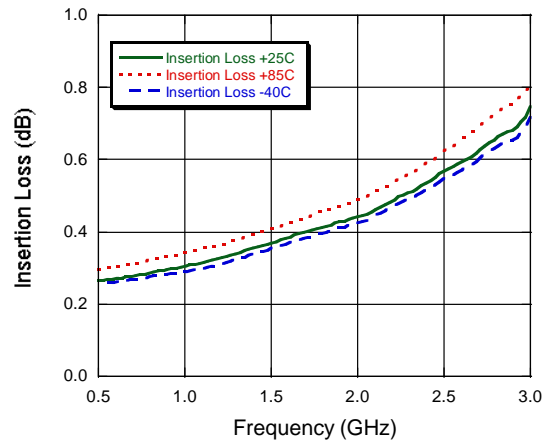

### Return Loss

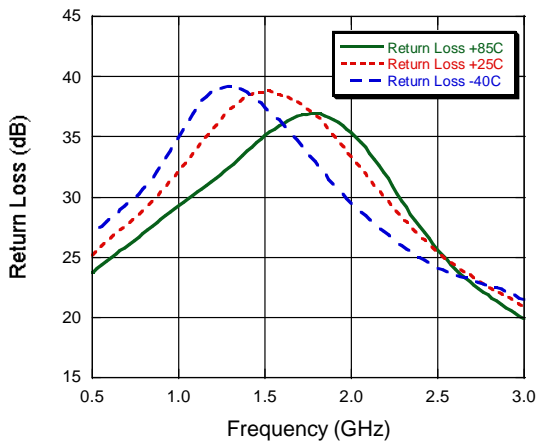

### Qualification

Qualified to M/A-COM specification REL-201, Process Flow -2.

### Handling Procedures

Please observe the following precautions to avoid damage:

### Static Sensitivity

Gallium Arsenide Integrated Circuits are sensitive to electrostatic discharge (ESD) and can be damaged by static electricity. Proper ESD control techniques should be used when handling these devices.