

Features

- Low Power Consumption: < 20 μ A @ +3 V
- High Isolation: 50 dB Typical @ 2 GHz
- Low Insertion Loss: 0.7 dB @ 2 GHz
- Positive 2.5 to 5 V Control
- Lead-Free MSOP-10 Package
- Halogen-Free "Green" Mold Compound
- 260°C Reflow Compatible
- RoHS* Compliant Version of SW-439

Description

The MASWSS0169 is a GaAs MMIC SPDT switch in a lead-free MSOP-10 surface mount plastic package. This part is ideal for high isolation, broadband switching requirements. Typical applications include synthesizer switching, transmit/receive switching, switch matrices and filter banks in systems such as radio and cellular equipment, PCM, GPS, and fiber optic modules.

The MASWSS0169 is fabricated as a monolithic GaAs MMIC using a 0.5 micron pHEMT process. The process features full passivation.

Ordering Information ¹

Part Number	Package
MASWSS0169	Bulk Packaging
MASWSS0169TR-3000	3000 piece reel
MASWSS0169SMB	Sample Board

1. Reference Application Note M513 for reel size information.

Truth Table ^{2,3}

Control V1	Control V2	RFC - RF1	RFC - RF2
0	1	Off	On
1	0	On	Off

2. External DC blocking capacitors are required on all RF ports.
3. "0" = 0 + 0.2 Vdc, "1" = +2.5 to +5 Vdc

Functional Schematic ⁴

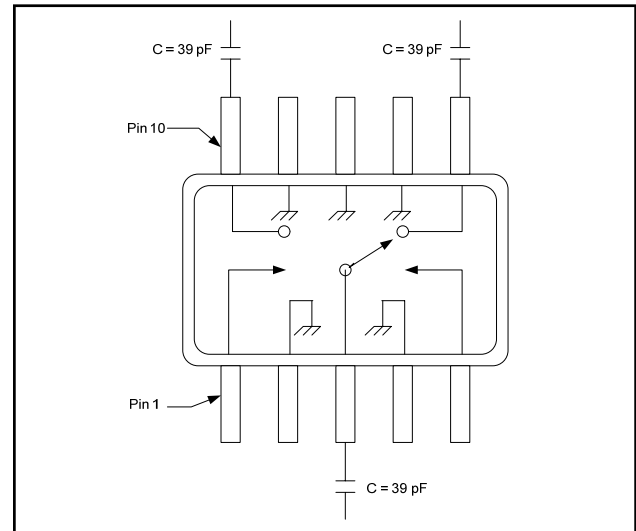

4. For improved performance at frequencies below 500 MHz, use larger value capacitors.

Pin Configuration

Pin No.	Function	Pin No.	Function
1	Control 1	6	RF Port 2
2	Ground	7	Ground
3	RF Input	8	Ground
4	Ground	9	Ground
5	Control 2	10	RF Port 1

Absolute Maximum Ratings ^{5,6}

Parameter	Absolute Maximum
Input Power	+30 dBm
Operating Voltage	+8.5 Volts
Operating Temperature	-40°C to +85°C
Storage Temperature	-65°C to +150°C

5. Exceeding any one or combination of these limits may cause permanent damage to this device.
6. M/A-COM Technology does not recommend sustained operation near these survivability limits.

* Restrictions on Hazardous Substances, European Union Directive 2002/95/EC.

ADVANCED: Data Sheets contain information regarding a product M/A-COM Technology Solutions is considering for development. Performance is based on target specifications, simulated results, and/or prototype measurements. Commitment to develop is not guaranteed.
PRELIMINARY: Data Sheets contain information regarding a product M/A-COM Technology Solutions has under development. Performance is based on engineering tests. Specifications are typical. Mechanical outline has been fixed. Engineering samples and/or test data may be available. Commitment to produce in volume is not guaranteed.

• **North America** Tel: 800.366.2266 / Fax: 978.366.2266
• **Europe** Tel: 44.1908.574.200 / Fax: 44.1908.574.300
• **Asia/Pacific** Tel: 81.44.844.8296 / Fax: 81.44.844.8298
Visit www.macomtech.com for additional data sheets and product information.

M/A-COM Technology Solutions Inc. and its affiliates reserve the right to make changes to the product(s) or information contained herein without notice.

GaAs High Isolation Switch DC - 3.0 GHz

Rev. V3

Electrical Specifications: $T_A = 25^\circ\text{C}$, $V_C = 0 / 3 \text{ V}$, $Z_0 = 50\Omega$

Parameter	Test Conditions	Units	Min	Typ	Max
Insertion Loss	500 MHz - 1.0 GHz	dB	—	0.55	0.65
	1.0 - 2.0 GHz	dB	—	0.65	—
	2.0 - 3.0 GHz	dB	—	0.80	—
Isolation	500 MHz - 2.0 GHz	dB	45	47	—
	2.0 - 3.0 GHz	dB	—	33	—
VSWR	0.25 - 3.0 GHz	Ratio	—	1.2:1	—
P1dB	500 MHz - 2.0 GHz, $V_C = 3 \text{ V}$	dBm	—	20	—
P1dB	500 MHz - 2.0 GHz, $V_C = 5 \text{ V}$	dBm	—	28	—
IP2	2 Tone, 900 MHz, 5 MHz Spacing, $V_C = 3 \text{ V}$	dBm	—	85	—
IP3	2 Tone, 900 MHz, 5 MHz Spacing, $V_C = 3 \text{ V}$	dBm	—	50	—
Ton, Toff	50% Control to 90% RF, 50% Control to 10% RF	ns	—	20	—
Trise, Tfall	10% to 90% RF, 90% to 10% RF	ns	—	10	—
Transients	In-band	mV	—	15	—
Control Current	$ V_C = 3.0 \text{ V}$	μA	—	5	20

Lead-Free MSOP-10[†]

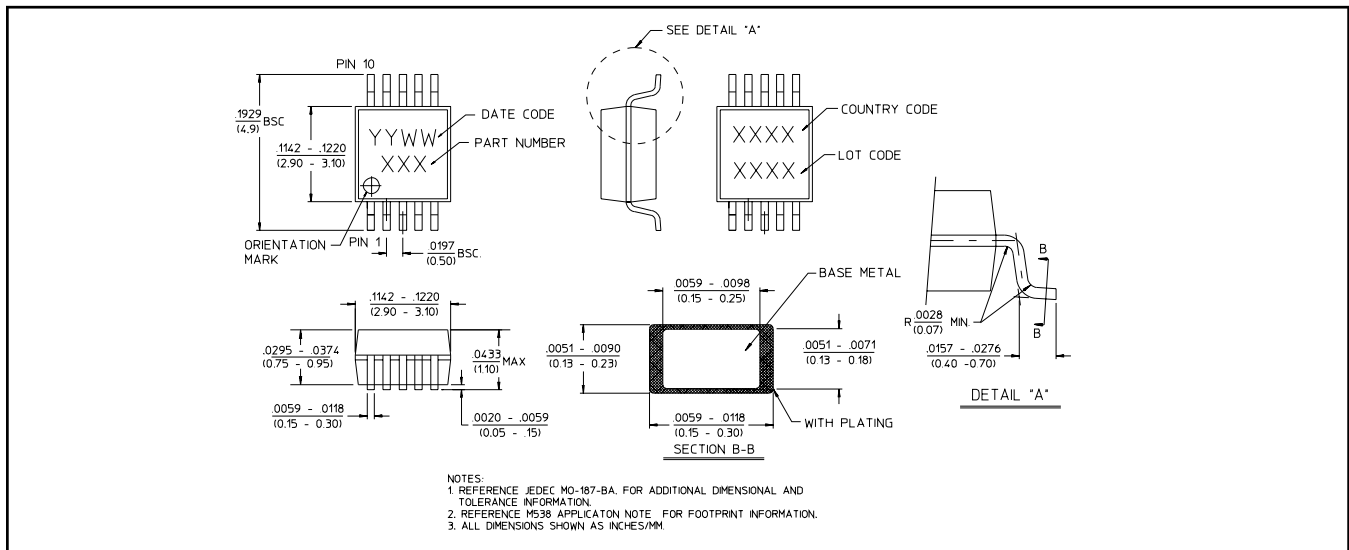

[†] Reference Application Note M538 for lead-free solder reflow recommendations.
 Meets JEDEC moisture sensitivity level 1 requirements.
 Plating is 100% matte tin over copper.

2

ADVANCED: Data Sheets contain information regarding a product M/A-COM Technology Solutions is considering for development. Performance is based on target specifications, simulated results, and/or prototype measurements. Commitment to develop is not guaranteed.
PRELIMINARY: Data Sheets contain information regarding a product M/A-COM Technology Solutions has under development. Performance is based on engineering tests. Specifications are typical. Mechanical outline has been fixed. Engineering samples and/or test data may be available. Commitment to produce in volume is not guaranteed.

• **North America** Tel: 800.366.2266 / Fax: 978.366.2266
 • **Europe** Tel: 44.1908.574.200 / Fax: 44.1908.574.300
 • **Asia/Pacific** Tel: 81.44.844.8296 / Fax: 81.44.844.8298
 Visit www.macomtech.com for additional data sheets and product information.

M/A-COM Technology Solutions Inc. and its affiliates reserve the right to make changes to the product(s) or information contained herein without notice.

Typical Performance Curves

Insertion Loss

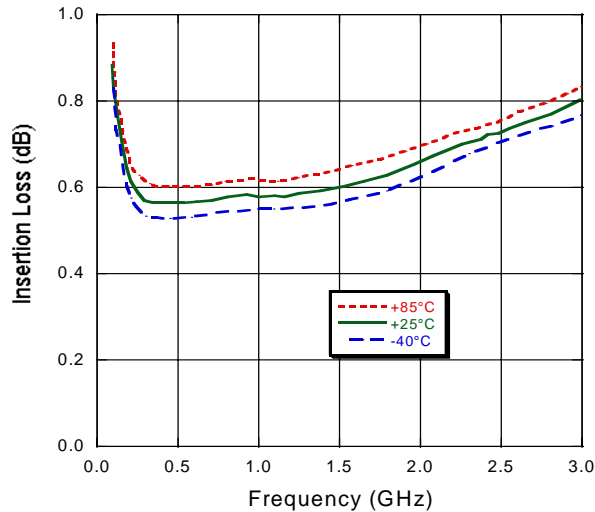

Isolation

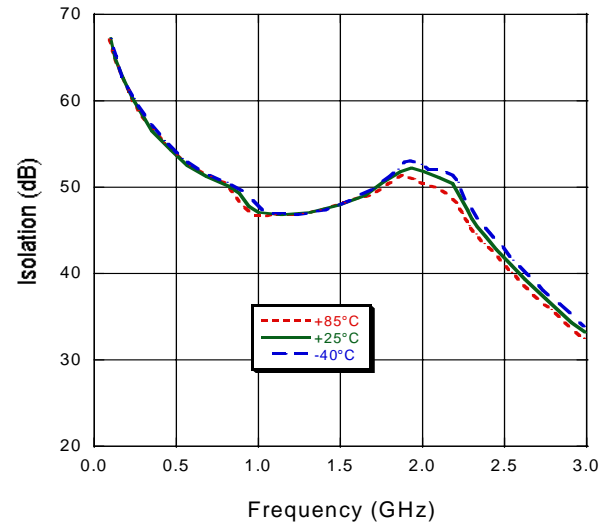

VSWR

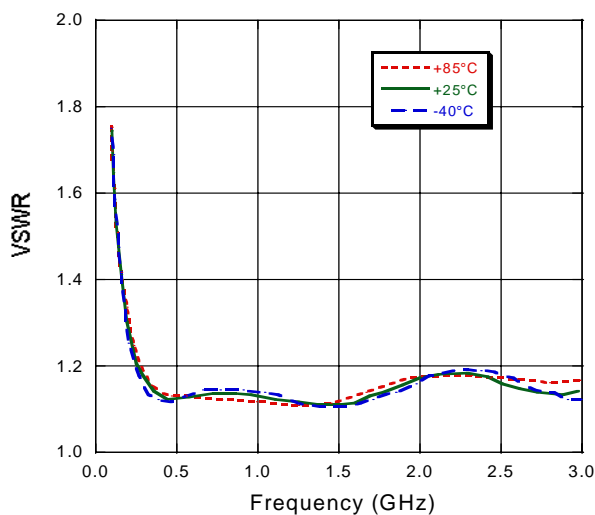

Handling Procedures

Please observe the following precautions to avoid damage:

Static Sensitivity

Gallium Arsenide Integrated Circuits are sensitive to electrostatic discharge (ESD) and can be damaged by static electricity. Proper ESD control techniques should be used when handling these devices.