

## Features

- Unbalanced (asymmetric) RF Paths
- Low Cross Modulation
- Low Insertion Loss: 0.5 dB at 1.0 GHz
- High Isolation: 20 dB at 2.0 GHz
- 0.5 micron GaAs PHEMT Process
- Lead-Free 3 mm 12-lead PQFN Package
- 100% Matte Tin Plating over Copper
- Halogen-Free "Green" Mold Compound
- 260°C Reflow Compatible
- RoHS\* Compliant Version of MASWSS0065

## Description

M/A-COM's MASWSS0199 is an industry leading GaAs PHEMT MMIC single pole three throw (SP3T) CDMA-GPS switch in a lead-free 3 mm 12-lead PQFN package.

The MASWSS0199 is uniquely configured to enable switching from a common antenna port to CDMA cellular, CDMA PCS, or GPS ports. The design is asymmetric and has been fully optimized for excellent cross modulation performance in CELL and PCS paths while still maintaining excellent insertion loss and isolation.

The MASWSS0199 is fabricated using a 0.5 micron gate length GaAs PHEMT process. The process features full passivation for performance and reliability.

## Ordering Information

Part Number	Package
MASWSS0199TR-3000	3000 Piece Reel
MASWSS0199SMB	Sample Test Board

Note: Reference Application Note M513 for reel size information.

## Functional Schematic

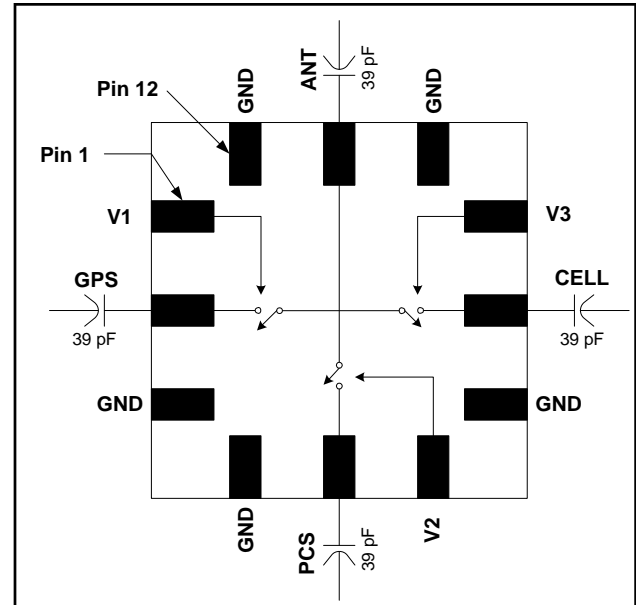

## Pin Configuration

Pin No.	Pin Name	Description
1	V1	Control 1
2	GPS	GPS Receive
3	GND	RF Ground
4	GND	RF Ground
5	PCS	PCS Transmit/Receive
6	V2	Control 2
7	GND	RF Ground
8	CELL	Cellular Transmit/Receive
9	V3	Control 3
10	GND	RF Ground
11	ANT	Antenna Port
12	GND	RF Ground
13	GND (paddle) <sup>1</sup>	RF Ground

1. The exposed pad centered on the package bottom must be connected to RF and DC ground.

\* Restrictions on Hazardous Substances, European Union Directive 2002/95/EC.

**Electrical Specifications:  $T_A = 25^\circ\text{C}$ ,  $V_C = 0\text{ V}/2.6\text{ V}$ ,  $Z_0 = 50\text{ Ohms}^2$**

Parameter	Test Conditions	Units	Min.	Typ.	Max.
Insertion Loss <sup>3</sup>	820 MHz	dB	—	0.5	0.7
	CELL Path				
	GPS Path			0.75	0.95
	1.5 GHz	dB	—	0.5	0.7
	1.9 GHz	dB	—	0.5	0.7
Isolation (CELL Path)	820 MHz	dB	27	30	—
	1.5 GHz	dB	—	26	—
	1.9 GHz	dB	—	24	—
Isolation (GPS Path)	820 MHz	dB	29	32	—
	1.5 GHz	dB	—	27	—
	1.9 GHz	dB	—	25	—
Isolation (PCS Path)	820 MHz	dB	25	27	—
	1.5 GHz	dB	—	22	—
	1.9 GHz	dB	—	20	—
Return Loss	All RF ports, DC – 2.5 GHz	dB	—	20	—
IP3	Two Tones, +22 dBm / tone, 1 MHz Spacing, 820 MHz	dBm	—	58	—
	Two Tones, +22 dBm / tone, 1 MHz Spacing, 1880 MHz	dBm	—	59	—
Cross Modulation CELL Path	Cell Band: Two-tone signal input: Tx1 = +22 dBm @ 820 MHz, Tx2 = +22 dBm @ 821 MHz, RX interfere = -30 dBm @ 869 MHz.	dBm	—	-113	—
Cross Modulation PCS Path	PCS Band: Two-tone signal input: Tx1 = +18 dBm @ 1880 MHz, Tx2 = +18 dBm @ 1881 MHz, RX interfere = -30 dBm @ 1960 MHz.	dBm	—	-115	—
P0.1 dB	820 MHz	dBm	—	37	—
	CELL Path				
	GPS Path			35	—
	1.5 GHz	dBm	—	35	—
	1.9 GHz	dBm	—	35	—
Trise, Tfall	10% to 90% RF, 90% to 10% RF	$\mu\text{S}$	—	0.05	—
Ton, Toff	50% control to 90% RF, and 50% control to 10% RF	$\mu\text{S}$	—	0.07	—
Transients	In Band	mV	—	50	—
Control Current	$ V_C  = 2.6\text{ V}$	$\mu\text{A}$	—	5	20

- For positive voltage control, external DC blocking capacitors are required on all RF ports.
- Insertion loss can be optimized by varying the DC blocking capacitor value, e.g. 1000 pF for 100 MHz - 1 GHz, 39 pF for 0.5 GHz - 3 GHz.

## Lead-Free 3 mm 12-Lead PQFN†

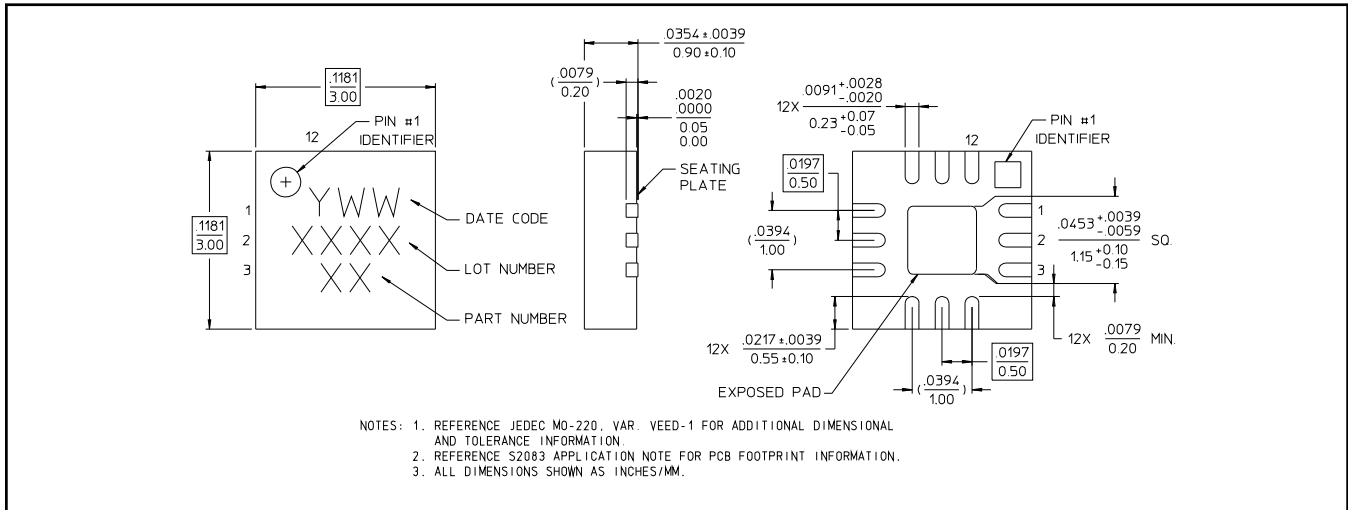

† Reference Application Note M538 for lead-free solder reflow recommendations.

## Absolute Maximum Ratings <sup>4,5</sup>

Parameter	Absolute Maximum
Input Power (0.5 - 2.5 GHz, 2.6 V Control)	+35 dBm
Operating Voltage	+8.5 volts
Operating Temperature	-40°C to +85°C
Storage Temperature	-65°C to +150°C

- Exceeding any one or combination of these limits may cause permanent damage to this device.
- M/A-COM does not recommend sustained operation near these survivability limits.

## Handling Procedures

Please observe the following precautions to avoid damage:

## Static Sensitivity

Gallium Arsenide Integrated Circuits are sensitive to electrostatic discharge (ESD) and can be damaged by static electricity. Proper ESD control techniques should be used when handling these devices.

## Truth Table <sup>6,7,8</sup>

V1	V2	V3	ANT-GPS	ANT-PCS	ANT-CELL
1	0	0	On	Off	Off
0	1	0	Off	On	Off
0	0	1	Off	Off	On

- For positive voltage control, external DC blocking capacitors are required on all RF ports.
- Differential voltage,  $V(\text{state } 1) - V(\text{state } 0)$ , must be +2.6 V minimum, but must not exceed +8.5 V.
- $0 = -5 \text{ V to } +2.4 \text{ V}$ ,  $1 = -2.4 \text{ V to } +5 \text{ V}$ .

## Typical Performance Curves

**Cell Path Isolation**

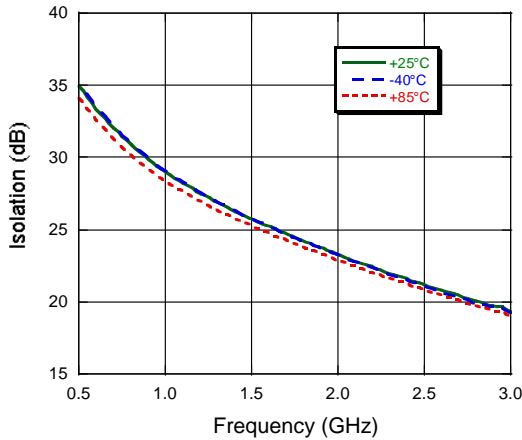

**Cell Path Insertion Loss**

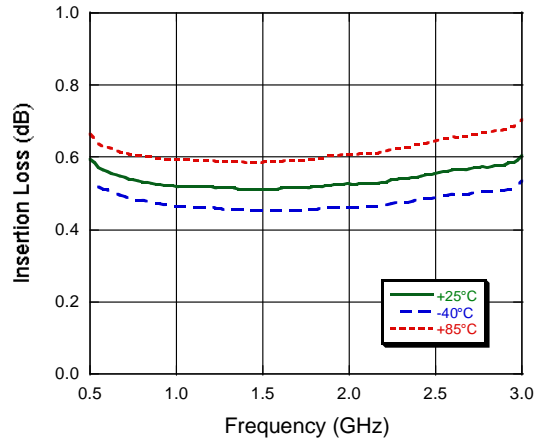

**GPS Path Isolation**

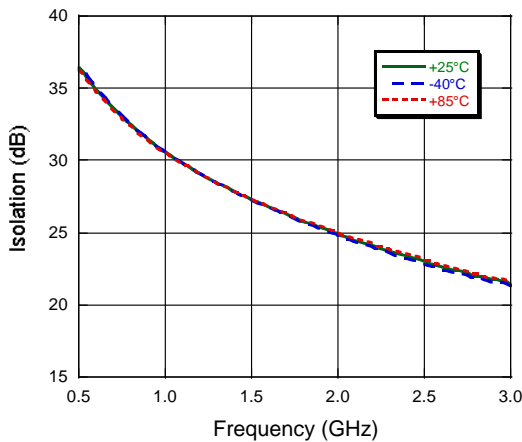

**GPS Path Insertion Loss**

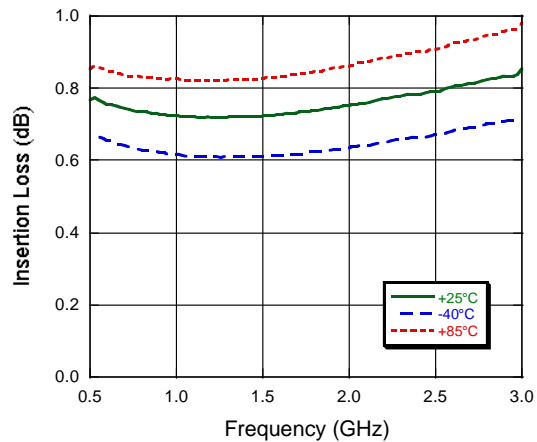

**PCS Path Isolation**

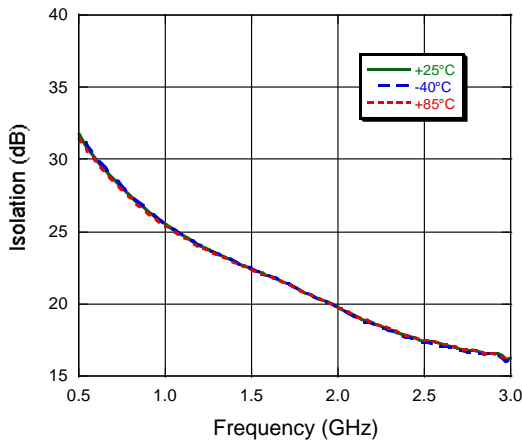

**PCS Path Insertion Loss**

