

Features

- Balanced (symmetrical) RF Ports
- Low Cross Modulation
- Low Insertion Loss: 0.55 dB at 1 GHz
- High Isolation: 21 dB at 2 GHz
- 0.5 micron GaAs PHEMT Process
- Lead-Free 3 mm 12-Lead PQFN Package
- 100% Matte Tin Plating over Copper
- Halogen-Free "Green" Mold Compound
- 260°C Reflow Compatible
- RoHS* Compliant Version of MASWSS0060

Description

M/A-COM's MASWSS0200 is an industry leading GaAs PHEMT MMIC single pole three throw (SP3T) CDMA-GPS switch in a lead-free 3 mm 12-lead PQFN package. The MASWSS0200 is uniquely configured to enable switching from a common antenna port to CDMA cellular, CDMA PCS, or GPS ports.

The design is symmetric and has been fully optimized for excellent cross modulation performance in all three paths while still maintaining excellent insertion loss and isolation. Note that since the design is symmetric, the user can assign CDMA cellular, CDMA PCS and GPS to ports RF1, RF2 or RF3 at his or her discretion.

The MASWSS0200 is fabricated using a 0.5 micron gate length GaAs PHEMT process. The process features full passivation for performance and reliability.

Ordering Information

Part Number	Package
MASWSS0200TR-3000	3000 piece reel
MASWSS0200SMB	Sample on Evaluation Board

Note: Reference Application Note M513 for reel size information.

Functional Schematic

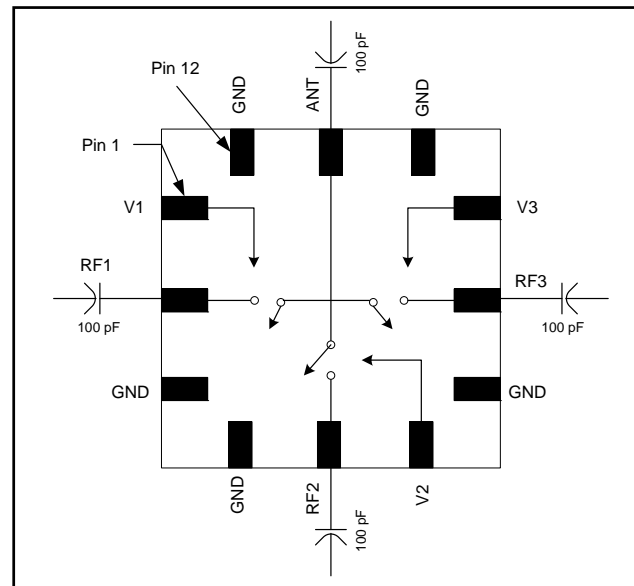

Pin Configuration

Pin No.	Function	Description
1	V1	Control 1
2	RF1	RF Port 1
3	GND	Ground
4	GND	Ground
5	RF2	RF Port 2
6	V2	Control 2
7	GND	RF Ground
8	RF3	RF Port 3
9	V3	Control 3
10	GND	RF Ground
11	ANT	Antenna Port
12	GND	RF Ground
13	GND (paddle)	RF Ground

* Restrictions on Hazardous Substances, European Union Directive 2002/95/EC.

Electrical Specifications: $T_A = 25^\circ\text{C}$, $Z_0 = 50 \Omega$ ¹

Parameter	Test Conditions	Units	Min.	Typ.	Max.
Insertion Loss ² (All Paths)	1.0 GHz	dB	—	0.55	0.70
	1.5 GHz	dB	—	0.60	0.75
	2.0 GHz	dB	—	0.70	0.90
Isolation	DC - 1.0 GHz	dB	23	27	—
	1.0 - 2.0 GHz	dB	18	21	—
	2.0 - 2.5 GHz	dB	16	20	—
Return Loss (All RF ports)	DC - 2.5 GHz	dB	—	20	—
IP3	Two Tone, +22 dBm/tone, 1 MHz Spacing, 820 MHz	dBm	—	62	—
	Two Tone, +22 dBm/tone, 1 MHz Spacing, 1880 MHz	dBm	—	61	—
Cross Modulation	For Cell Band: Two-tone signal input: Tx1 = +22 dBm @ 820 MHz, Tx2 = +22 dBm @ 821 MHz, RX interfere = -23 dBm @ 869 MHz	dBm	—	-101	—
	For PCS Band: Two-tone signal input: Tx1 = +18 dBm @ 1880 MHz, Tx2 = +18 dBm @ 1881 MHz, RX interfere = -23 dBm @ 1960 MHz	dBm	—	-102	—
P.1dB	$V_c = 0 \text{ V} / 2.7 \text{ V}$, 1 GHz	dBm	—	36	—
Trise, Tfall	10% to 90% RF, 90% to 10% RF, 900 MHz	μS	—	0.06	—
Ton, Toff	50% control to 90% RF, and 50% control to 10% RF, 900 MHz	μS	—	0.09	—
Transients	In Band	mV	—	70	—
Control Current	$V_c = 0 \text{ V} / 2.7 \text{ V}$	μA	—	—	30

- External DC blocking capacitors are required on all RF ports.
- Insertion Loss can be optimized by varying the DC blocking capacitor value, e.g. 1000 pF for 100 MHz - 500 MHz, 100 pF for 0.5 - 2.5 GHz.

Absolute Maximum Ratings^{3,4}

Parameter	Absolute Maximum
Input Power (0.5 - 2.5 GHz, 2.7 V Control)	+36 dBm
Control Voltage	± 8.5 volts
Operating Temperature	-40°C to $+85^\circ\text{C}$
Storage Temperature	-65°C to $+150^\circ\text{C}$

- Exceeding any one or combination of these limits may cause permanent damage to this device.
- M/A-COM does not recommend sustained operation near these survivability limits.

Truth Table^{5,6}

V1	V2	V3	ANT-RF1	ANT-RF2	ANT-RF3
1	0	0	On	Off	Off
0	1	0	Off	On	Off
0	0	1	Off	Off	On

- Differential voltage, V (state 1) - V (state 0) must be 2.6 V minimum and must not exceed 8.5 V.
- 0 = -5 V to 2.4 V, 1 = -2.4 V to 5 V.

Typical Performance Curves @ +25°C

VSWR

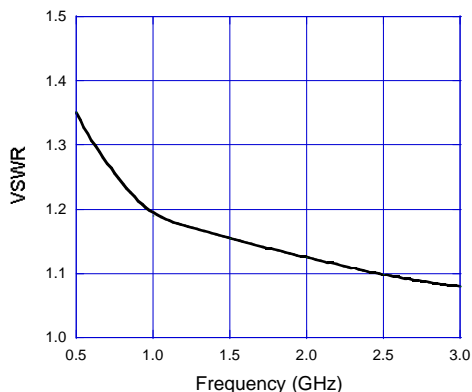

Isolation

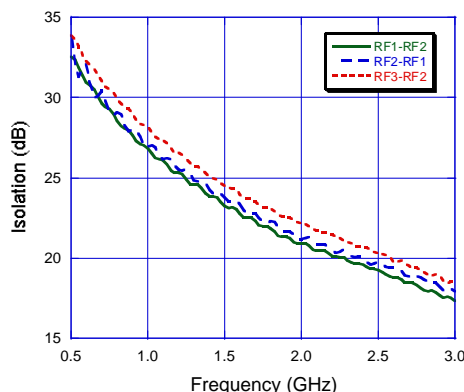

Insertion Loss

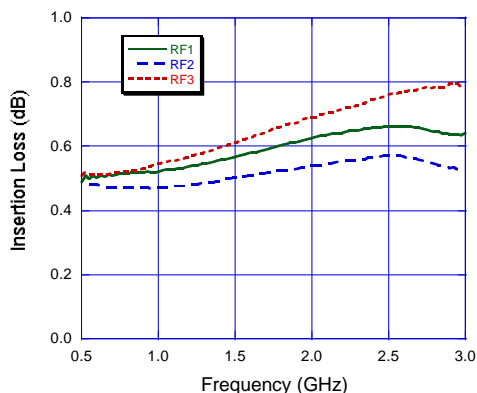

Qualification

Qualified to M/A-COM specification REL-201, Process Flow -2.

Handling Procedures

Please observe the following precautions to avoid damage:

Static Sensitivity

Gallium Arsenide Integrated Circuits are sensitive to electrostatic discharge (ESD) and can be damaged by static electricity. Proper ESD control techniques should be used when handling these devices.

Lead-Free 3 mm 12-Lead PQFN†

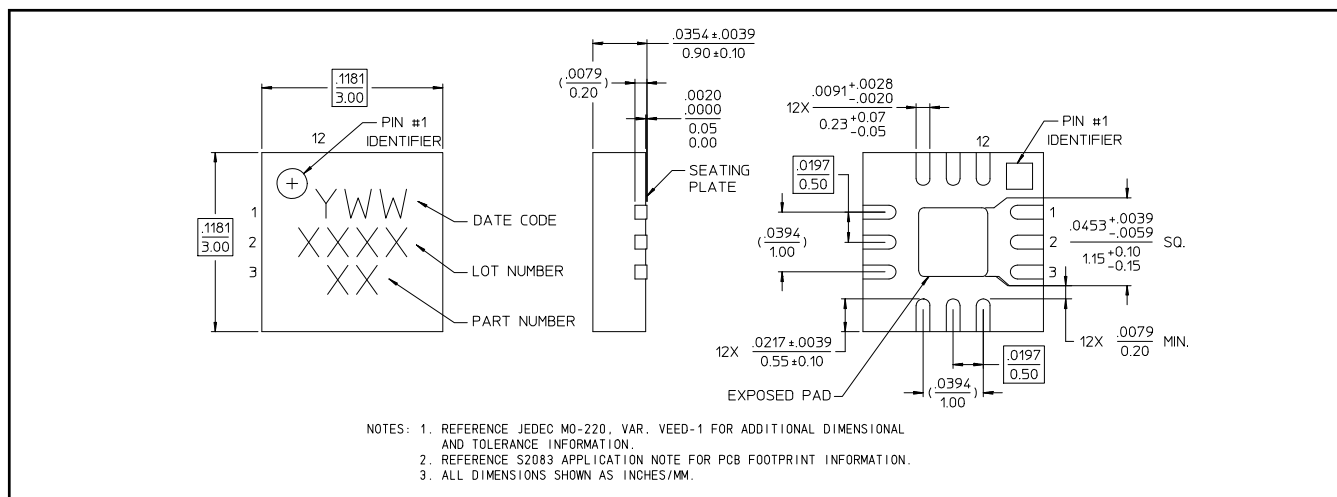

† Reference Application Note M538 for lead-free solder reflow recommendations.