

## Features

- Low Voltage Operation: 2.7 V
- High IP3: +56 dBm
- Low Insertion Loss: 0.30 dB at 1 GHz
- High Isolation: 25 dB at 1 GHz
- 0.5 micron GaAs PHEMT Process
- Lead-Free SC70 Package
- Halogen-Free “Green” Mold Compound
- 260°C Reflow Compatible
- RoHS\* Compliant Version of MASWSS0117

## Description

The MASWSS0204 is a GaAs pHEMT MMIC single pole double throw (SPDT) high power switch in a low cost SC70 six lead package. The MASWSS0204 is ideally suited for applications where high power, low control voltage, low insertion loss, high isolation, small size and low cost are required.

Typical applications are for CDMA handset systems that connect separate transceiver and/or GPS functions to a common antenna, as well as other related handset and general purpose applications. The MASWSS0204 can be used in all systems operating up to 3 GHz requiring high power at low control voltage.

The MASWSS0204 is fabricated using a 0.5 micron gate length GaAs pHEMT process. The process features full passivation for performance and reliability.

## Functional Block Diagram

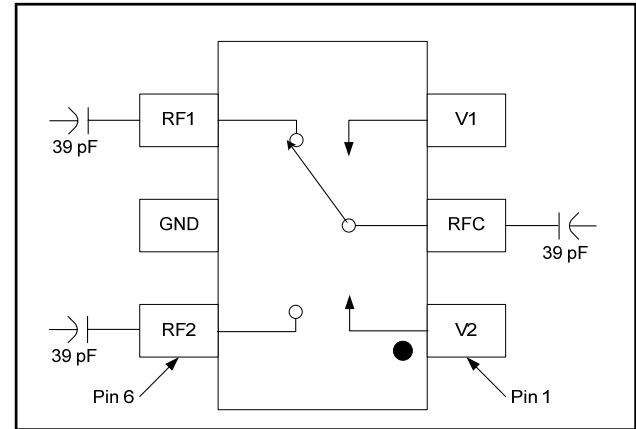

## Pin Configuration

| Pin No. | Pin Name | Description |
|---------|----------|-------------|
| 1       | V2       | Vcontrol 2  |
| 2       | RFC      | RF Common   |
| 3       | V1       | Vcontrol 1  |
| 4       | RF1      | RF Port 1   |
| 5       | GND      | RF Ground   |
| 6       | RF2      | RF Port 2   |

## MASWSS0204 orientation in tape

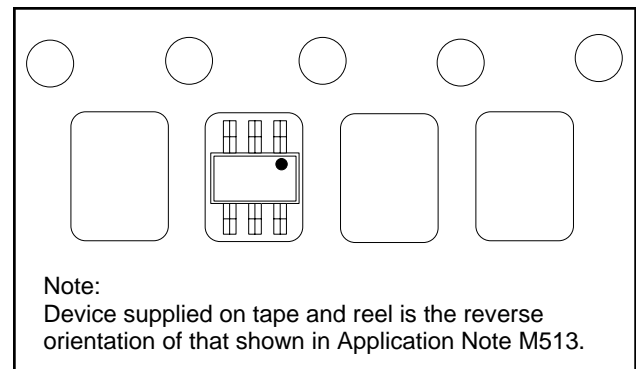

## Ordering Information <sup>1,2</sup>

| Part Number       | Package           |
|-------------------|-------------------|
| MASWSS0204        | Bulk Packaging    |
| MASWSS0204TR-3000 | 3000 piece reel   |
| MASWSS0204SMB     | Sample Test Board |

1. Reference Application Note M513 for reel size information.
2. All sample boards include 5 loose parts.

\* Restrictions on Hazardous Substances, European Union Directive 2002/95/EC.

## GaAs SPDT 2.7 V High Power Switch DC - 3.0 GHz

Rev. V3

**Electrical Specifications:  $T_A = 25^\circ\text{C}$ ,  $V_C = 0\text{ V}/2.7\text{ V}$ ,  $Z_0 = 50\ \Omega$  <sup>3</sup>**

| Parameter                   | Test Conditions  | Units         | Min. | Typ. | Max. |
|-----------------------------|--|---------------|------|------|------|
| Insertion Loss <sup>4</sup> | DC - 1 GHz   | dB            | —    | 0.30 | 0.65 |
|                             | 1 - 2 GHz  |               | —    | 0.35 | —    |
|                             | 2 - 3 GHz  |               | —    | 0.35 | —    |
| Isolation                   | DC - 1 GHz   | dB            | 23   | 25   | —    |
|                             | 1 - 2 GHz  |               | —    | 19   | —    |
|                             | 2 - 3 GHz  |               | —    | 15   | —    |
| Return Loss                 | DC - 3 GHz   | dB            | —    | 20   | —    |
| IP3                         | 825 MHz<br>Two Tone, +24 dBm Total Pin, 5 MHz Spacing  | dBm           | —    | 56   | —    |
| Cross Modulation            | For Cell Band: Two-tone signal input:<br>$T_{x1} = +22\text{ dBm @ } 820\text{ MHz}$ ,<br>$T_{x2} = +22\text{ dBm @ } 821\text{ MHz}$ ,<br>$R_x\text{ interfere} = -23\text{ dBm @ } 869\text{ MHz}$ .   | dBm           | —    | -99  | —    |
|                             | For PCS Band: Two-tone signal input:<br>$T_{x1} = +18\text{ dBm @ } 1880\text{ MHz}$ ,<br>$T_{x2} = +18\text{ dBm @ } 1881\text{ MHz}$ ,<br>$R_x\text{ interfere} = -23\text{ dBm @ } 1960\text{ MHz}$ . | dBm           | —    | -94  | —    |
| P0.1dB                      | 1 GHz  | dBm           | —    | 38   | —    |
| Trise, Tfall                | 10% to 90% RF, 90% to 10% RF   | ns            | —    | 70   | —    |
| Ton, Toff                   | 50% control to 90% RF,<br>50% control to 10% RF  | ns            | —    | 100  | —    |
| Transients                  | In Band  | mV            | —    | 25   | —    |
| Control Current             | $V_C = 2.7\text{ V}$   | $\mu\text{A}$ | —    | 5    | 20   |

3. For positive voltage control, external DC blocking capacitors are required on all RF ports.

4. Insertion loss can be optimized by varying the DC blocking capacitor value, e.g. 1000 pF for 100 MHz - 1 GHz, 39 pF for 0.5 - 3 GHz.

### Absolute Maximum Ratings <sup>5,6</sup>

| Parameter                                 | Absolute Maximum |
|---|------------------|
| Input Power<br>(0.5 - 3 GHz, 3 V Control) | +38 dBm          |
| Operating Voltage                         | +8.5 volts       |
| Operating Temperature                     | -40°C to +85°C   |
| Storage Temperature                       | -65°C to +150°C  |

5. Exceeding any one or combination of these limits may cause permanent damage to this device.

6. M/A-COM Technology does not recommend sustained operation near these survivability limits.

### Truth Table <sup>7,8,9</sup>

| V1 | V2 | ANT- RF1 | ANT - RF2 |
|----|----|----------|-----------|
| 1  | 0  | On       | Off       |
| 0  | 1  | Off      | On        |

7. For positive voltage control, external DC blocking capacitors are required on all RF ports.

8. Differential voltage,  $V(\text{state } 1) - V(\text{state } 0)$ , must be +2.7 V minimum, but must not exceed 8.5 V.

9. 0 = -5 V to +2.3 V, 1 = -2.3 V to +5 V.

## Typical Performance Curves, 39 pF

### Insertion Loss

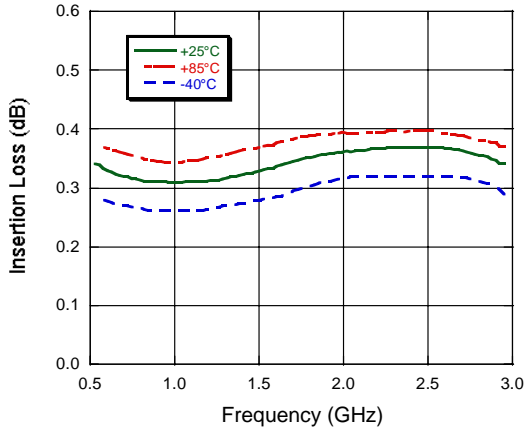

### Isolation

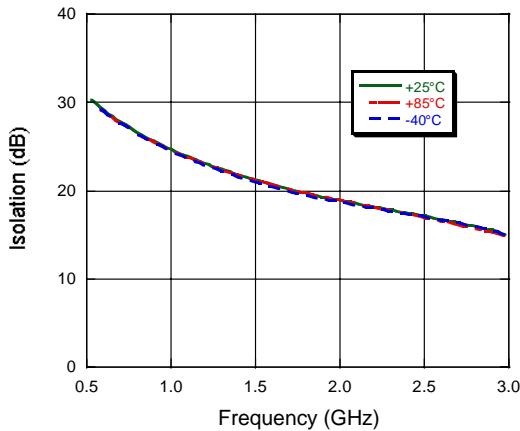

### Return Loss

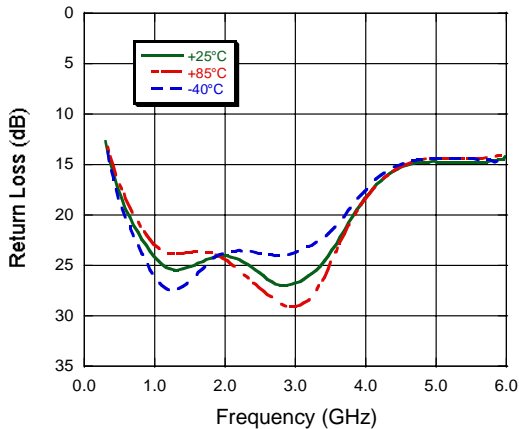

### Qualification

Qualified to M/A-COM specification REL-201, Process Flow -2.

### Handling Procedures

Please observe the following precautions to avoid damage:

### Static Sensitivity

Gallium Arsenide Integrated Circuits are sensitive to electrostatic discharge (ESD) and can be damaged by static electricity. Proper ESD control techniques should be used when handling these devices.

### Lead-Free SC70 Plastic Package<sup>†</sup>

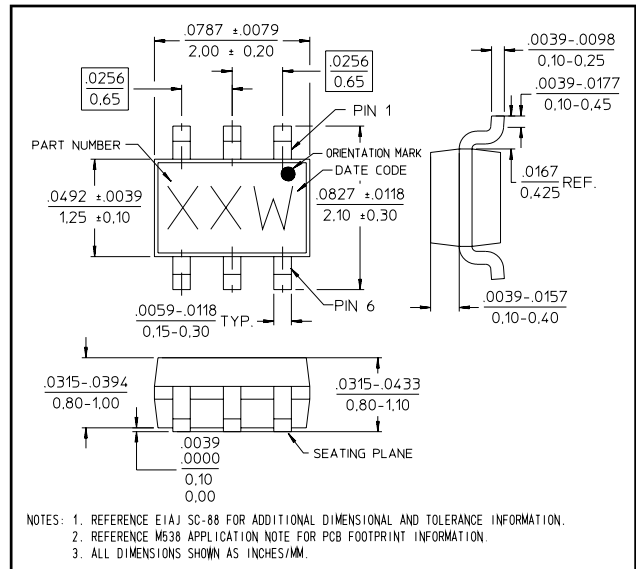

<sup>†</sup> Reference Application Note M538 for lead-free solder reflow recommendations.  
 Meets JEDEC moisture sensitivity level 1 requirements.  
 Plating is 100% matte tin over copper.