

MRF454



The RF Line NPN Silicon Power Transistor 80W, 30MHz, 12.5V

M/A-COM Products
Released - Rev. 07.07

Designed for power amplifier applications in industrial, commercial and amateur radio equipment to 30 MHz.

- Specified 12.5 V, 30 MHz characteristics
- Output power = 80 W
- Minimum gain = 12 dB
- Efficiency = 50%

Product Image

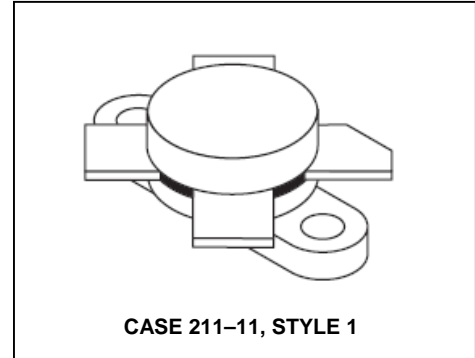

MAXIMUM RATINGS

Rating	Symbol	Value	Unit
Collector-Emitter Voltage	V_{CEO}	25	Vdc
Collector-Base Voltage	V_{CBO}	45	Vdc
Emitter-Base Voltage	V_{EBO}	4.0	Vdc
Collector Current — Continuous	I_C	20	Adc
Total Device Dissipation @ $T_C = 25^\circ\text{C}$ Derate above 25°C	P_D	250 1.43	Watts W/ $^\circ\text{C}$
Storage Temperature Range	T_{stg}	-65 to +150	$^\circ\text{C}$

THERMAL CHARACTERISTICS

Characteristic	Symbol	Max	Unit
Thermal Resistance, Junction to Case	$R_{\theta JC}$	0.7	$^\circ\text{C/W}$

ELECTRICAL CHARACTERISTICS ($T_C = 25^\circ\text{C}$ unless otherwise noted.)

Characteristic	Symbol	Min	Typ	Max	Unit
----------------	--------	-----	-----	-----	------

OFF CHARACTERISTICS

Collector-Emitter Breakdown Voltage ($I_C = 100 \text{ mAdc}$, $I_B = 0$)	$V_{(BR)CEO}$	18	—	—	Vdc
Collector-Emitter Breakdown Voltage ($I_C = 50 \text{ mAdc}$, $V_{BE} = 0$)	$V_{(BR)CES}$	36	—	—	Vdc
Emitter-Base Breakdown Voltage ($I_E = 10 \text{ mAdc}$, $I_C = 0$)	$V_{(BR)EBO}$	4.0	—	—	Vdc

ON CHARACTERISTICS

DC Current Gain ($I_C = 5.0 \text{ Adc}$, $V_{CE} = 5.0 \text{ Vdc}$)	h_{FE}	40	—	150	—
--	----------	----	---	-----	---

DYNAMIC CHARACTERISTICS

Output Capacitance ($V_{CB} = 15 \text{ Vdc}$, $I_E = 0$, $f = 1.0 \text{ MHz}$)	C_{ob}	—	—	250	pF
--	----------	---	---	-----	----

The RF Line NPN Silicon Power Transistor

80W, 30MHz, 12.5V

M/A-COM Products
Released - Rev. 07.07

FUNCTIONAL TESTS (Figure 1)

Common-Emitter Amplifier Power Gain ($V_{CC} = 12.5 \text{ Vdc}$, $P_{out} = 80 \text{ W}$, $f = 30 \text{ MHz}$)	G_{pe}	12	—	—	dB
Collector Efficiency ($V_{CC} = 12.5 \text{ Vdc}$, $P_{out} = 80 \text{ W}$, $f = 30 \text{ MHz}$)	η	50	—	—	%
Series Equivalent Input Impedance ($V_{CC} = 12.5 \text{ Vdc}$, $P_{out} = 80 \text{ W}$, $f = 30 \text{ MHz}$)	Z_{in}	—	.938-j.341	—	Ohms
Series Equivalent Output Impedance ($V_{CC} = 12.5 \text{ Vdc}$, $P_{out} = 80 \text{ W}$, $f = 30 \text{ MHz}$)	Z_{out}	—	1.16-j.201	—	Ohms
Parallel Equivalent Input Impedance ($V_{CC} = 12.5 \text{ Vdc}$, $P_{out} = 80 \text{ W}$, $f = 30 \text{ MHz}$)	—	—	1.06 Ω 1817 pF	—	—
Parallel Equivalent Output Impedance ($V_{CC} = 12.5 \text{ Vdc}$, $P_{out} = 80 \text{ W}$, $f = 30 \text{ MHz}$)	—	—	1.19 Ω 777 pF	—	—

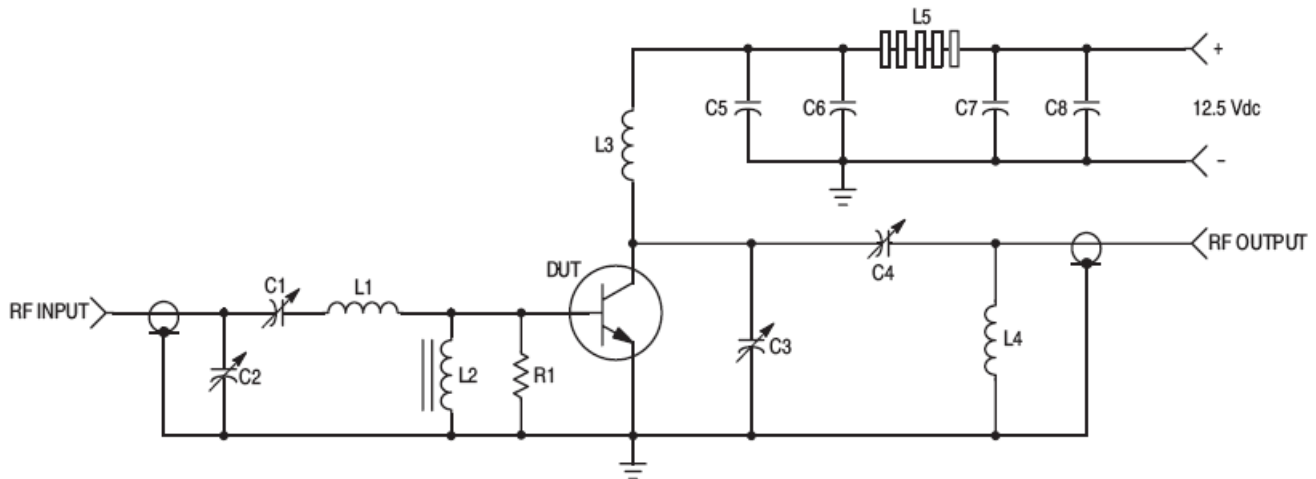

C1, C2, C4 — ARCO 469
C3 — ARCO 466
C5 — 1000 pF, UNELCO
C6, C7 — 0.1 μF Disc Ceramic
C8 — 1000 μF /15 V Electrolytic
R1 — 10 Ohm/1.0 Watt, Carbon

L1 — 3 Turns, #18 AWG, 5/16" I.D., 5/16" Long
L2 — VK200-20/4B, FERROXCUBE
L3 — 12 Turns, #18 AWG Enameled Wire, 1/4" I.D., Close Wound
L4 — 3 Turns 1/8" O.D. Copper Tubing, 3/8" I.D., 3/4" Long
L5 — 7 FERRITE Beads, FERROXCUBE #56-590-65/3B

Figure 1. 30 MHz Test Circuit Schematic

MRF454



The RF Line NPN Silicon Power Transistor
80W, 30MHz, 12.5V

M/A-COM Products
Released - Rev. 07.07

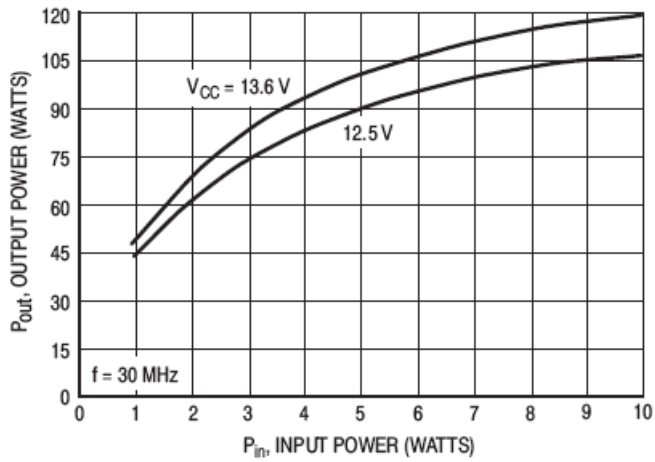

Figure 2. Output Power versus Input Power

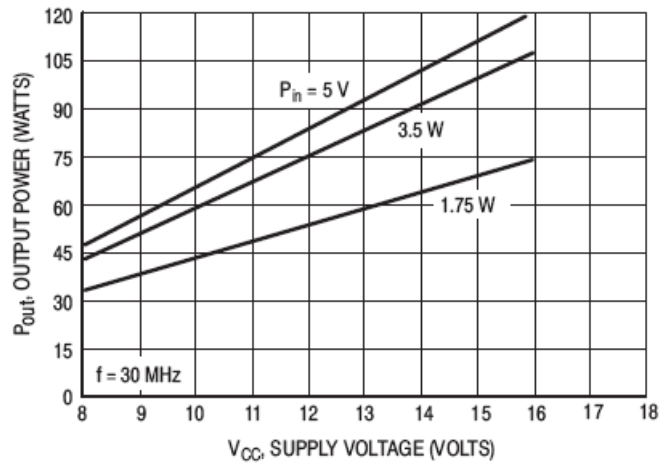

Figure 3. Output Power versus Supply Voltage

ADVANCED: Data Sheets contain information regarding a product M/A-COM Technology Solutions is considering for development. Performance is based on target specifications, simulated results, and/or prototype measurements. Commitment to develop is not guaranteed.

PRELIMINARY: Data Sheets contain information regarding a product M/A-COM Technology Solutions has under development. Performance is based on engineering tests. Specifications are typical. Mechanical outline has been fixed. Engineering samples and/or test data may be available. Commitment to produce in volume is not guaranteed.

- **North America** Tel: 800.366.2266 / Fax: 978.366.2266
 - **Europe** Tel: 44.1908.574.200 / Fax: 44.1908.574.300
 - **Asia/Pacific** Tel: 81.44.844.8296 / Fax: 81.44.844.8298
- Visit www.macomtech.com for additional data sheets and product information.

M/A-COM Technology Solutions, Inc. and its affiliates reserve the right to make changes to the products or information contained herein without notice.

MRF454



The RF Line NPN Silicon Power Transistor
80W, 30MHz, 12.5V

M/A-COM Products
Released - Rev. 07.07

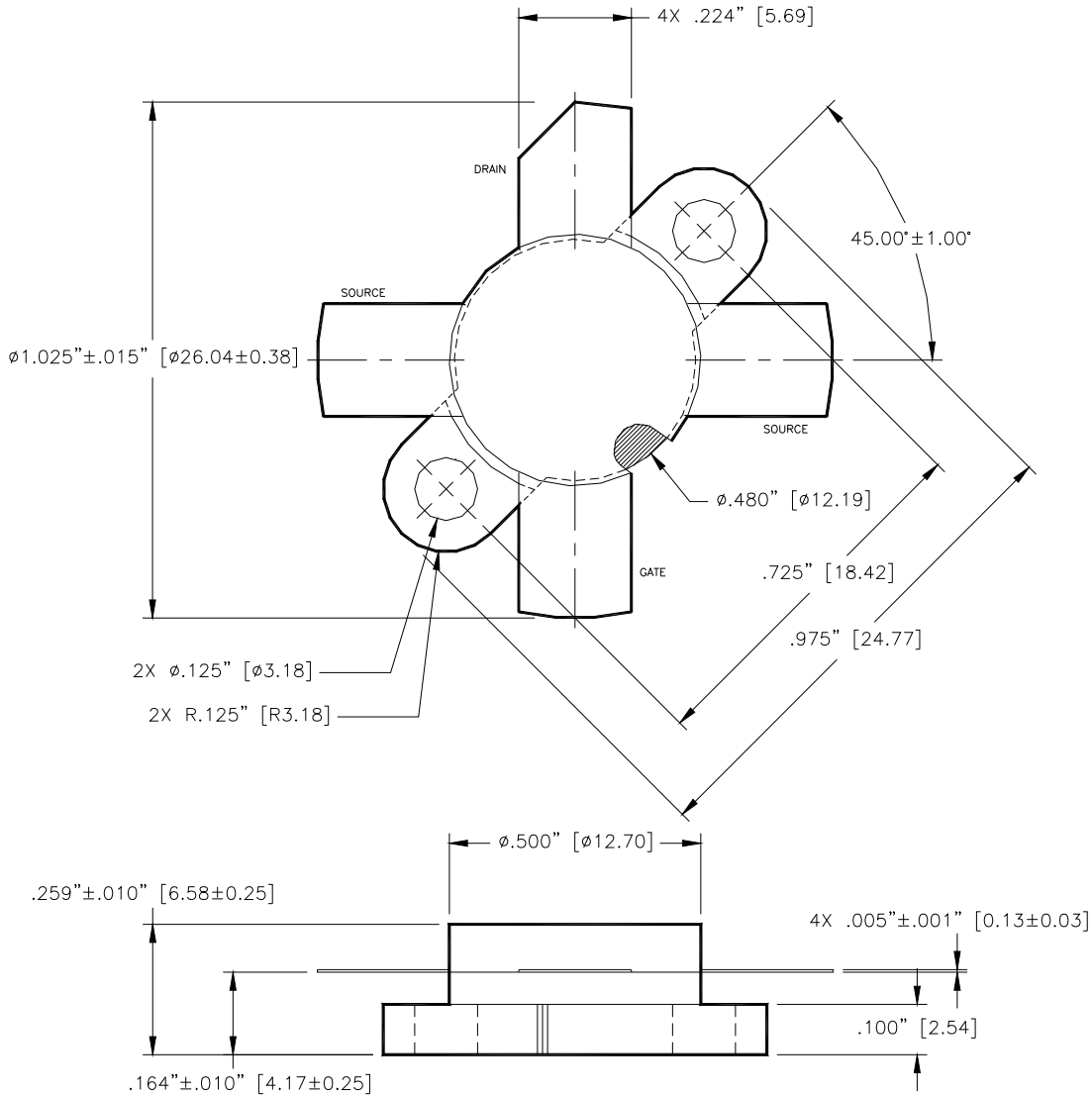

Unless otherwise noted, tolerances are inches ± 0.005 " [millimeters ± 0.13 mm]

ADVANCED: Data Sheets contain information regarding a product M/A-COM Technology Solutions is considering for development. Performance is based on target specifications, simulated results, and/or prototype measurements. Commitment to develop is not guaranteed.
PRELIMINARY: Data Sheets contain information regarding a product M/A-COM Technology Solutions has under development. Performance is based on engineering tests. Specifications are typical. Mechanical outline has been fixed. Engineering samples and/or test data may be available. Commitment to produce in volume is not guaranteed.

- **North America** Tel: 800.366.2266 / Fax: 978.366.2266
- **Europe** Tel: 44.1908.574.200 / Fax: 44.1908.574.300
- **Asia/Pacific** Tel: 81.44.844.8296 / Fax: 81.44.844.8298

Visit www.macomtech.com for additional data sheets and product information.

M/A-COM Technology Solutions Inc. and its affiliates reserve the right to make changes to the products or information contained herein without notice.