

PH1214-40M



Radar Pulsed Power Transistor
40W, 1.2-1.4 GHz, 150µs Pulse, 10% Duty

M/A-COM Products
Released, 30 May 07

Features

- NPN silicon microwave power transistors
- Common base configuration
- Broadband Class C operation
- High efficiency inter-digitized geometry
- Diffused emitter ballasting resistors
- Gold metallization system
- Internal input and output impedance matching
- Hermetic metal/ceramic package
- RoHS compliant

Outline Drawing

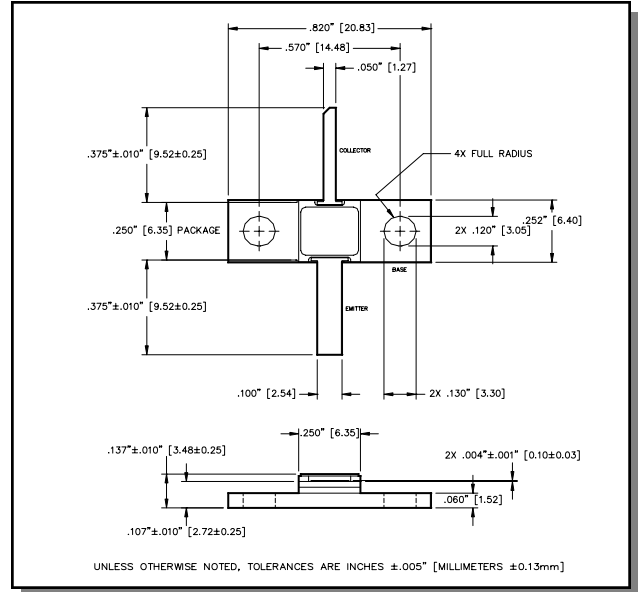

Absolute Maximum Ratings at 25°C

Parameter	Symbol	Rating	Units
Collector-Emitter Voltage	V_{CES}	70	V
Emitter-Base Voltage	V_{EBO}	3.0	V
Collector Current (Peak)	I_C	3.0	A
Power Dissipation @ +25°C	P_{TOT}	100	W
Storage Temperature	T_{STG}	-65 to +200	°C
Junction Temperature	T_J	200	°C

Electrical Specifications: $T_C = 25 \pm 5^\circ\text{C}$ (Room Ambient)

Parameter	Test Conditions	Frequency	Symbol	Min	Max	Units
Collector-Emitter Breakdown Voltage	$I_C = 15\text{mA}$		BV_{CES}	70	-	V
Collector-Emitter Leakage Current	$V_{CE} = 40\text{V}$		I_{CES}	-	2.0	mA
Thermal Resistance	$V_{CC} = 40\text{V}$, $P_{out} = 40\text{W}$	F = 1.2, 1.3, 1.4 GHz	$R_{TH(JC)}$	-	1.7	°C/W
Output Power	$V_{CC} = 40\text{V}$, $P_{out} = 40\text{W}$	F = 1.2, 1.3, 1.4 GHz	P_{IN}	-	5.65	W
Power Gain	$V_{CC} = 40\text{V}$, $P_{out} = 40\text{W}$	F = 1.2, 1.3, 1.4 GHz	G_P	8.5	-	dB
Collector Efficiency	$V_{CC} = 40\text{V}$, $P_{out} = 40\text{W}$	F = 1.2, 1.3, 1.4 GHz	η_C	50	-	%
Input Return Loss	$V_{CC} = 40\text{V}$, $P_{out} = 40\text{W}$	F = 1.2, 1.3, 1.4 GHz	RL	-	-6	dB
Load Mismatch Tolerance	$V_{CC} = 40\text{V}$, $P_{out} = 40\text{W}$	F = 1.2, 1.3, 1.4 GHz	VSWR-T	-	3:1	-
Load Mismatch Stability	$V_{CC} = 40\text{V}$, $P_{out} = 40\text{W}$	F = 1.2, 1.3, 1.4 GHz	VSWR-S	-	1.5:1	-

1

ADVANCED: Data Sheets contain information regarding a product M/A-COM Technology Solutions is considering for development. Performance is based on target specifications, simulated results, and/or prototype measurements. Commitment to develop is not guaranteed.

PRELIMINARY: Data Sheets contain information regarding a product M/A-COM Technology Solutions has under development. Performance is based on engineering tests. Specifications are typical. Mechanical outline has been fixed. Engineering samples and/or test data may be available. Commitment to produce in volume is not guaranteed.

• **North America** Tel: 800.366.2266 / Fax: 978.366.2266
 • **Europe** Tel: 44.1908.574.200 / Fax: 44.1908.574.300
 • **Asia/Pacific** Tel: 81.44.844.8296 / Fax: 81.44.844.8298
 Visit www.macomtech.com for additional data sheets and product information.

M/A-COM Technology Solutions, Inc. and its affiliates reserve the right to make changes to the product(s) or information contained herein without notice.

Typical RF Performance

Freq. (GHz)	Pin (W)	Pout (W)	Gain (dB)	Ic (A)	Eff (%)	RL (dB)	VSWR-S (1.5:1)	VSWR-T (3:1)
1.2	3.48	40	10.60	1.60	62.7	-11.0	S	P
1.3	3.75	40	10.28	1.57	63.5	-12.2	S	P
1.4	4.04	40	9.96	1.56	63.9	-12.9	S	P

Gain vs. Frequency

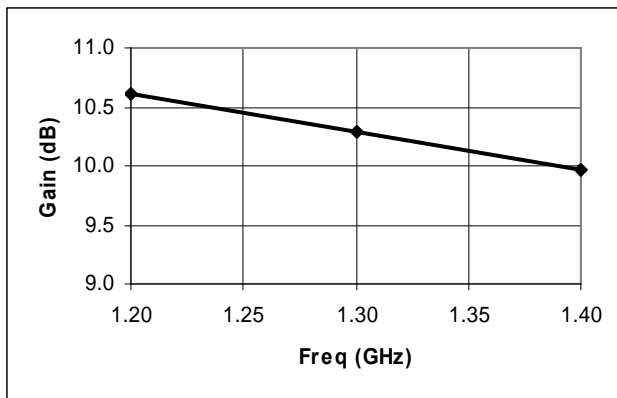

Collector Efficiency vs. Frequency

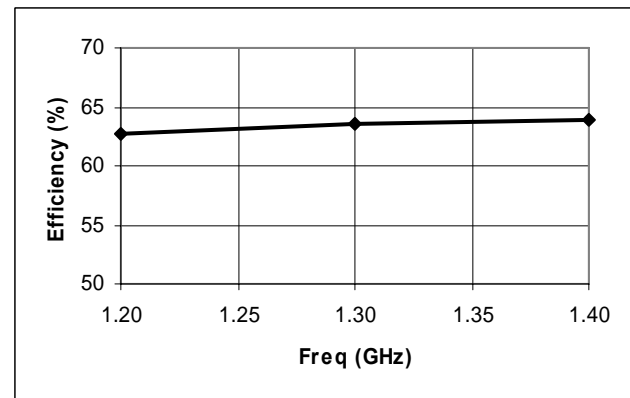

RF Test Fixture Impedance

F (GHz)	Z _{IF} (Ω)	Z _{OF} (Ω)
1.2	2.6 - j4.7	2.8 - j0.7
1.3	2.5 - j4.1	3.3 - j0.2
1.4	2.3 - j3.7	3.0 + j0.4

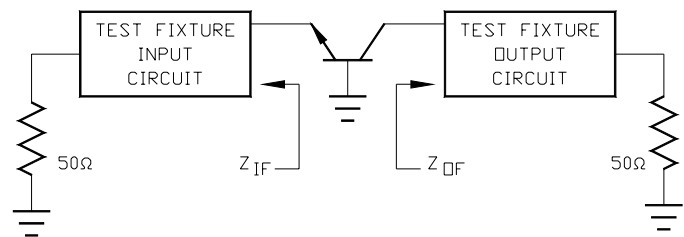

Radar Pulsed Power Transistor
40W, 1.2-1.4 GHz, 150µs Pulse, 10% Duty

M/A-COM Products
Released, 30 May 07

Test Fixture Circuit Dimensions

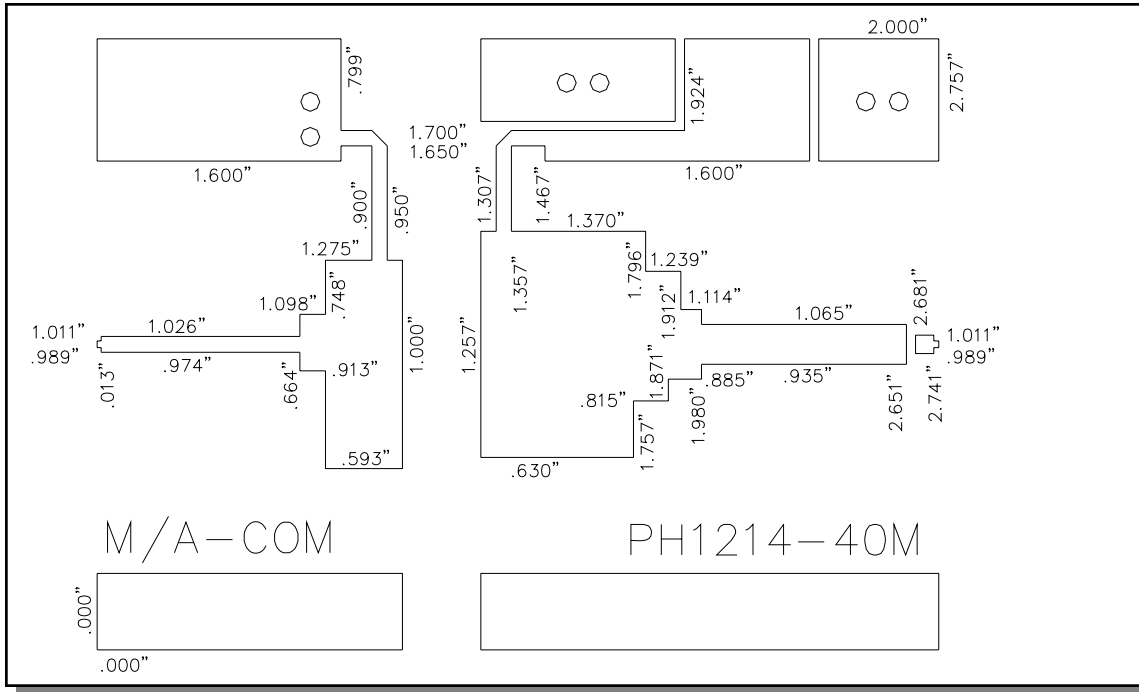

Test Fixture Assembly

