

Radar Pulsed Power Transistor
65W, 3.1-3.5 GHz, 100µs Pulse, 10% Duty

M/A-COM Products
Released, 10 Aug 07

Features

- NPN silicon microwave power transistors
- Common base configuration
- Broadband Class C operation
- High efficiency inter-digitized geometry
- Diffused emitter ballasting resistors
- Gold metallization system
- Internal input and output impedance matching
- Hermetic metal/ceramic package
- RoHS compliant

Outline Drawing

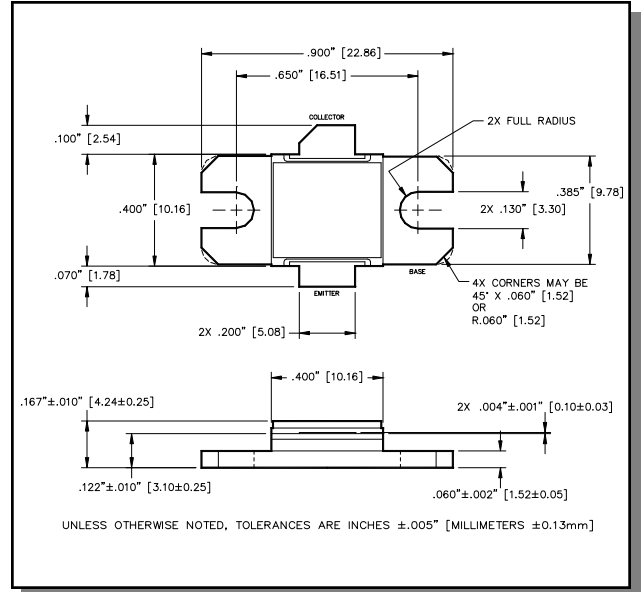

Absolute Maximum Ratings at 25°C

Parameter	Symbol	Rating	Units
Collector-Emitter Voltage	V_{CES}	65	V
Emitter-Base Voltage	V_{EBO}	3.0	V
Collector Current (Peak)	I_C	7.7	A
Power Dissipation @ +25°C	P_{TOT}	350	W
Storage Temperature	T_{STG}	-65 to +200	°C
Junction Temperature	T_J	200	°C

Electrical Specifications: $T_C = 25 \pm 5^\circ\text{C}$ (Room Ambient)

Parameter	Test Conditions	Frequency	Symbol	Min	Max	Units
Collector-Emitter Breakdown Voltage	$I_C = 25\text{mA}$		BV_{CES}	65	-	V
Collector-Emitter Leakage Current	$V_{CE} = 36\text{V}$		I_{CES}	-	5.0	mA
Thermal Resistance	$V_{CC} = 36\text{V}$, $P_{out} = 65\text{W}$	$F = 3.1, 3.3, 3.5\text{ GHz}$	$R_{TH(JC)}$	-	0.5	°C/W
Output Power	$V_{CC} = 36\text{V}$, $P_{out} = 65\text{W}$	$F = 3.1, 3.3, 3.5\text{ GHz}$	P_{IN}	-	11.6	W
Power Gain	$V_{CC} = 36\text{V}$, $P_{out} = 65\text{W}$	$F = 3.1, 3.3, 3.5\text{ GHz}$	G_P	75	-	dB
Collector Efficiency	$V_{CC} = 36\text{V}$, $P_{out} = 65\text{W}$	$F = 3.1, 3.3, 3.5\text{ GHz}$	η_C	35	-	%
Input Return Loss	$V_{CC} = 36\text{V}$, $P_{out} = 65\text{W}$	$F = 3.1, 3.3, 3.5\text{ GHz}$	RL	-	-6	dB
Load Mismatch Tolerance	$V_{CC} = 36\text{V}$, $P_{out} = 65\text{W}$	$F = 3.1, 3.3, 3.5\text{ GHz}$	VSWR-T	-	2:1	-

Radar Pulsed Power Transistor
65W, 3.1-3.5 GHz, 100µs Pulse, 10% Duty

M/A-COM Products
Released, 10 Aug 07

Typical RF Performance

Freq. (GHz)	Pin (W)	Pout (W)	Gain (dB)	Ic (A)	Eff (%)	RL (dB)	VSWR-T (2:1)
3.1	8.0	65	9.09	4.35	41.5	-10.5	P
3.3	8.3	65	8.95	4.24	42.6	-9.8	P
3.5	9.8	65	8.23	4.64	38.9	-17.3	P

Gain vs. Frequency

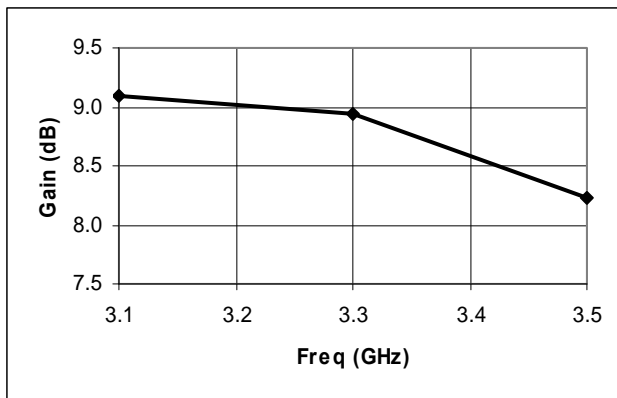

Collector Efficiency vs. Frequency

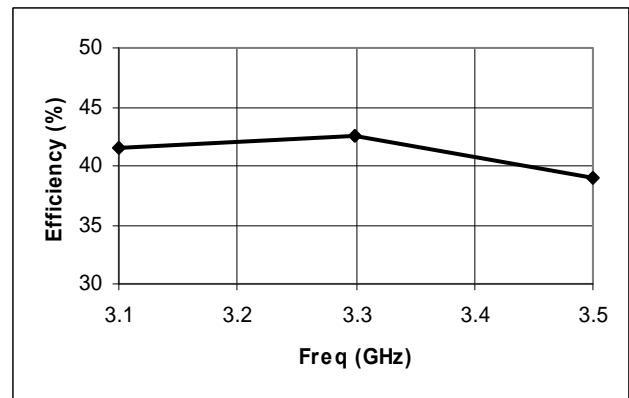

RF Test Fixture Impedance

F (GHz)	Z _{IF} (Ω)	Z _{OF} (Ω)
3.1	8.9 - j11.2	5.2 - j11.0
3.3	8.7 - j8.6	4.2 - j8.8
3.5	8.6 - j6.0	4.7 - j7.0

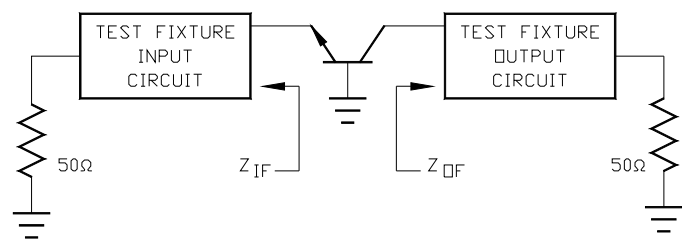

Radar Pulsed Power Transistor
65W, 3.1-3.5 GHz, 100µs Pulse, 10% Duty

M/A-COM Products
Released, 10 Aug 07

Test Fixture Circuit Dimensions

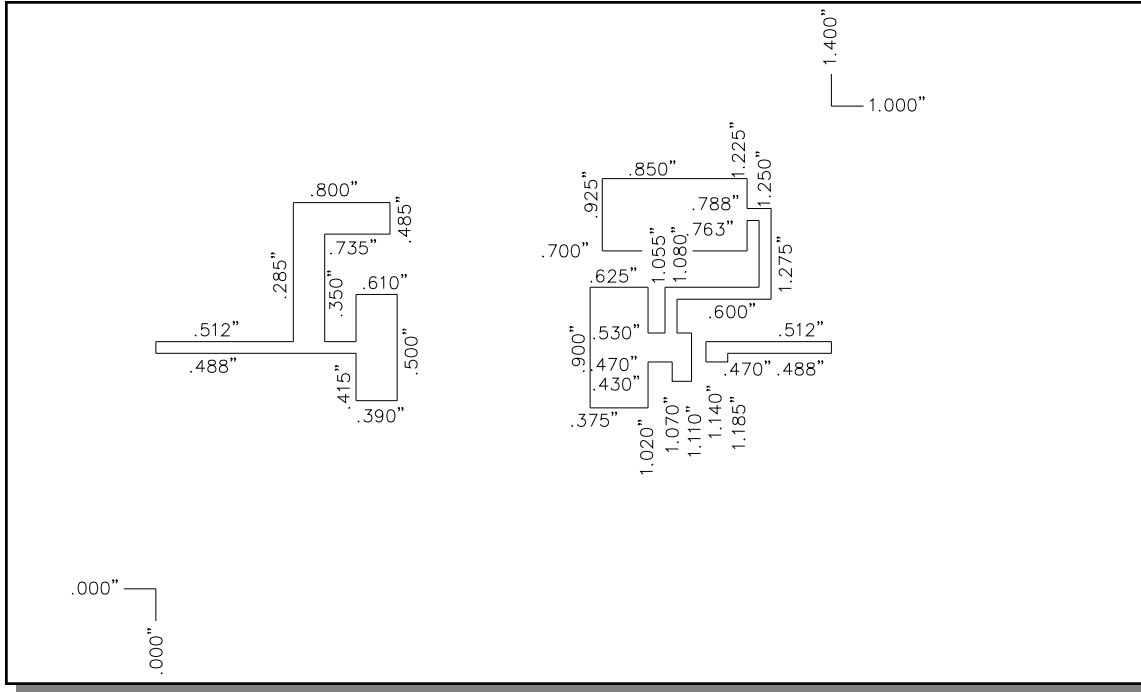

Test Fixture Assembly

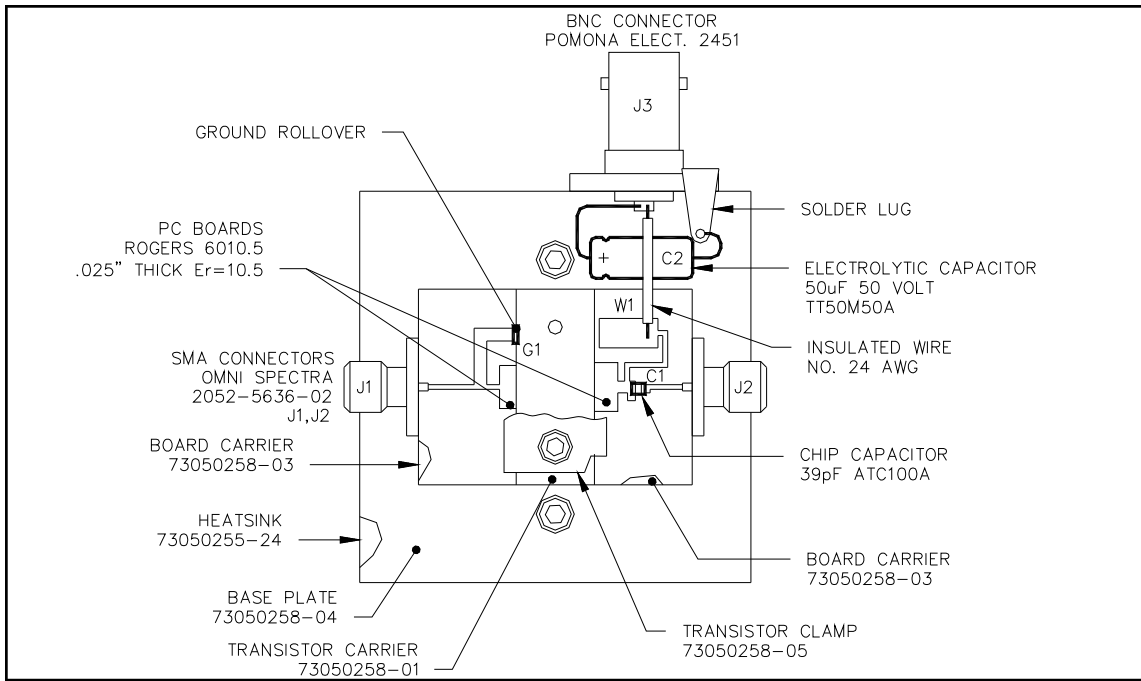

ADVANCED: Data Sheets contain information regarding a product M/A-COM Technology Solutions is considering for development. Performance is based on target specifications, simulated results, and/or prototype measurements. Commitment to develop is not guaranteed.

PRELIMINARY: Data Sheets contain information regarding a product M/A-COM Technology Solutions has under development. Performance is based on engineering tests. Specifications are typical. Mechanical outline has been fixed. Engineering samples and/or test data may be available. Commitment to produce in volume is not guaranteed.

- **North America** Tel: 800.366.2266 / Fax: 978.366.2266
 - **Europe** Tel: 44.1908.574.200 / Fax: 44.1908.574.300
 - **Asia/Pacific** Tel: 81.44.844.8296 / Fax: 81.44.844.8298
- Visit www.macomtech.com for additional data sheets and product information.

M/A-COM Technology Solutions, Inc. and its affiliates reserve the right to make changes to the products or information contained herein without notice.