



FAST RECOVERY BRIDGE

EDF1A THRU EDF1D

VOLTAGE RANGE

50 to 200 Volts

CURRENT

1.0 Ampere

FEATURES

- Glass passivated chip junction
- Superfast recovery time for high efficiency
- Ideal for surface mount applications
- Low leakage
- High forward surge current capability
- High temperature soldering guaranteed:
260°C/10 seconds at terminals

MECHANICAL DATA

- Case: Molded plastic body
- Epoxy: UL94V-0 rate flame retardant
- Polarity: Molded on body
- Leadp: Plated terminals solderable per MIL-STD-202E method 208C
- Weight: 0.04 ounce, 1.0 gram

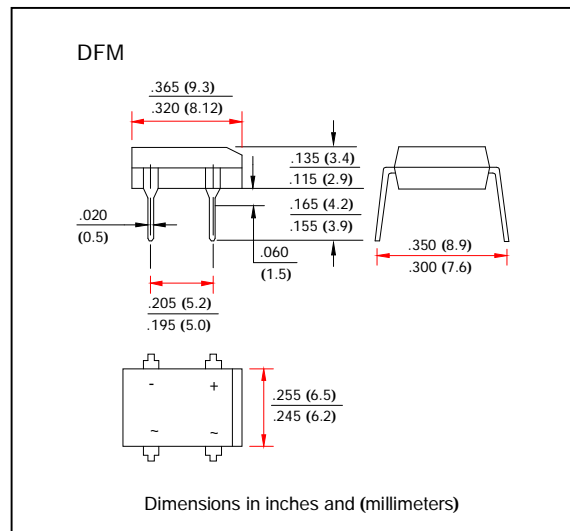

MAXIMUM RATINGS AND ELECTRICAL CHARACTERISTICS

- Ratings at 25°C ambient temperature unless otherwise specified
- Single Phase, half wave, 60Hz, resistive or inductive load
- For capacitive load derate current by 20%

	SYMBOLS	EDF1A	EDF1B	EDF1C	EDF1D	UNIT
Maximum Reverse Peak Repetitive Voltage	V_{RRM}	50	100	150	200	Volts
Maximum RMS Voltage	V_{RMS}	35	70	105	140	Volts
Maximum DC Blocking Voltage	V_{DC}	50	100	150	200	Volts
Maximum Average Forward Rectified Output Current, 0.06" (1.5mm) lead length at $T_A=40^\circ\text{C}$ (Note 2)	$I_{(AV)}$	1.0				Amps
Peak Forward Surge Current 8.3ms single half sine-wave superimposed on rated load (JEDEC Method)	I_{FSM}	50				Amps
Rating for Fusing ($t < 8.3\text{ms}$)	I^2t	10				A^2s
Maximum Instantaneous Forward Voltage drop Per Bridge element at 1.0A	V_F	1.05				Volts
Maximum Reverse Current at rated DC blocking voltage per element	I_R	$T_A=25^\circ\text{C}$	5.0			μAmps
		$T_A=125^\circ\text{C}$	0.5			mAmps
Maximum reverse Recovery Time (Note 1)	T_{rr}	50				nS
Typical Junction Capacitance (Note 3)	C_J	25				pF
Typical Thermal Resistance (Note 2)	$R_{\theta JA}$	40				$^\circ\text{C}/\text{W}$
Operating and Storage Temperature Range	T_J, T_{STG}	-55 to +150				$^\circ\text{C}$

- Notes:**
1. Test condition: $I_F=0.5\text{A}$, $I_R=1.0\text{A}$, $I_{RR}=0.25\text{A}$
 2. Unit mounted on P.C.B. with $0.51" \times 0.51"$ (13×13mm) copper pads.
 3. Measured at 1.0MHz and applied reverse voltage of 4.0 Volts.

RATINGS AND CHARACTERISTIC CURVES EDF1A THRU EDF1D

FIG. 1- DERATING CURVES OUTPUT RECTIFIED CURRENT

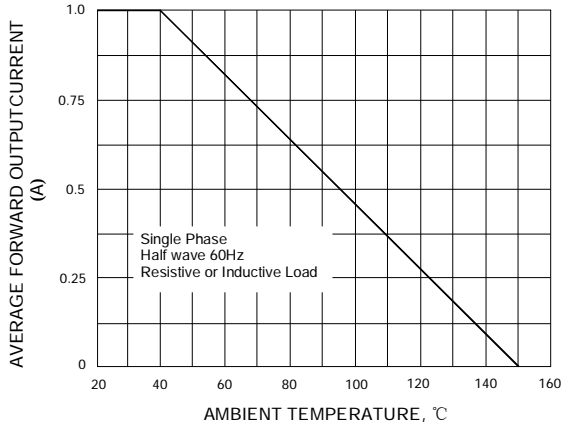

FIG. 2- MAXIMUM NON-REPETITIVE PEAK FORWARD SURGE CURRENT

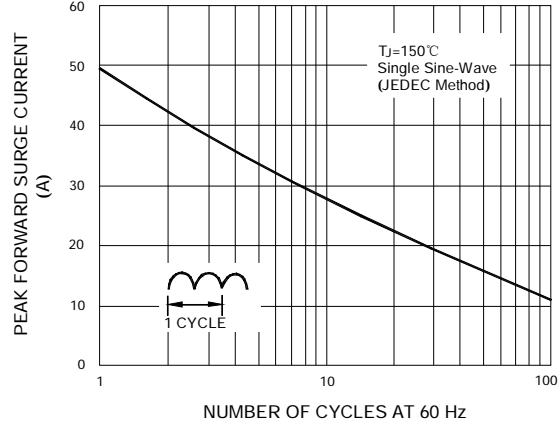

FIG. 3- TYPICAL FORWARD CHARACTERISTICS PER LEG

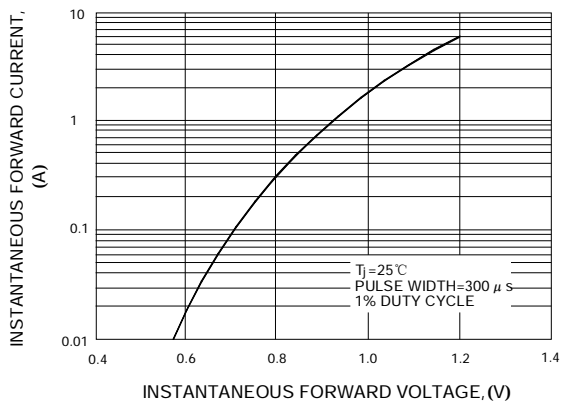

FIG. 4- TYPICAL REVERSE LEAKAGE CHARACTERISTICS PER LEG

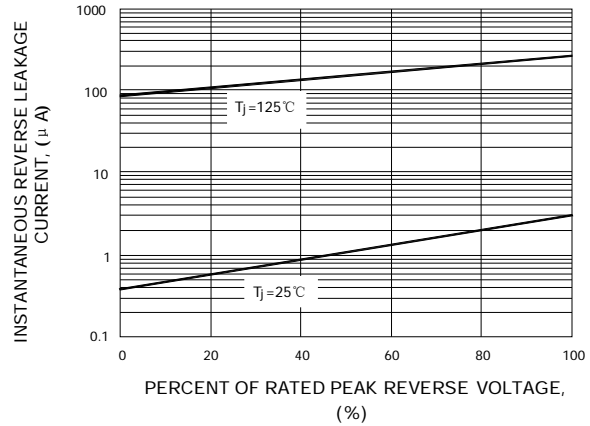

FIG. 5- TYPICAL JUNCTION CAPACITANCE PER LEG

