



# PRESS FIT AVALANCHE AUTOMOTIVE RECTIFIER (MOTOROLA)

PRMA30L

AVALANCHE VOLTAGE 20 to 24 Volts

CURRENT 30 Amperes

## Technical Specifecation:

### Features:

- High power capability
- Economical
- Avalanche Voltage: 20V to 24V

## MECHANICAL DATA

- Case: Copper case
- Epoxy: UL94-0 rate flame ratardant
- Polarity: As marked of case bottom
- Structural: With cell
- Technology cell vacuum soldered
- Lead: Plated slug, solderable per MIL-STD-202E Method 208C
- Weight: 0.30 ounce 8.5 Grams

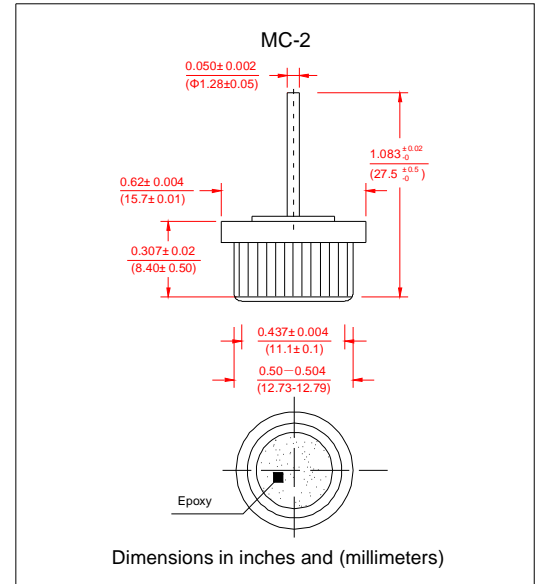

## MAXIMUM RATINGS AND ELECTRICAL CHARACTERISTICS

- Ratings at 25°C ambient temperature unless otherwise specified
- Single Phase, half wave, 60Hz, resistive or inductive load
- For capacitive load derate current by 20%

Electrical Characteristics @ 25°C	SYMBOLS	MIN	NOMINAL	MAX	UNITS
Peak Repetitive Reverse Voltage	$V_{RRM}$		17		Volts
Working Peak Reverse Voltage	$V_{RRM}$		17		
DC Blocking Voltage	$V_{DC}$		17		
Average Rectified Forward Current ( $T_c=125^\circ\text{C}$ )	$I_o$		30		Amps
Repetitive Peak Reverse Surge Current $T_c=10\text{msec}$ Dury Cycle < 1%	$I_{RSM}$		30		Amps
Breakdown Voltage ( $V_{br}@I_r=100\text{mA}$ , $T_c=25^\circ\text{C}$ )	$V_{br1}$	20	22	24	Volts
$I_r=90\text{Amps}$ , $T_c=150^\circ\text{C}$ , $PW=80\text{usec}$	$V_{br2}$			32	Volts
Forward Voltage Drop @ $I_f=100\text{Amps}$ < 300usec	$V_F$		1.05	1.08	Volts
Peak Forward Surge Current	$I_{FSM}$		500		Amps
Reverse Leakage ( $V_R=17\text{Vdc}$ ) $T_A=25^\circ\text{C}$	$I_R$		1.0	2.0	uAmps
Operating and Storage Junction Temperature Range	$T_J, T_{STG}$		-65 to +175		°C

**Notes:** 1. Enough heatsink must be considered in application.

