



## SCHOTTKY BARRIER RECTIFIER

SR1620C THRU SR16100C

VOLTAGE RANGE

20 to 100 Volts

CURRENT

16.0 Amperes

### FEATURES

- Plastic package has Underwriters Laboratory Flammability Classification 94V-O utilizing Flame Retardant Epoxy Molding Compound
- Exceeds environmental standards of MIL-S-19500/228
- Low power loss, high efficiency
- Low forward voltage high current capability
- High surge capacity
- For use in low voltage, high frequency inverters. Free wheeling, and polarity protection applications

### MECHANICAL DATA

- Case: TO-220AB molded plastic
- Terminals: Lead solderable per MIL-STD-202 METHOD 208
- Polarity: AS marked
- Mounting position: Any
- Weight: 0.08ounce, 2.24 grams

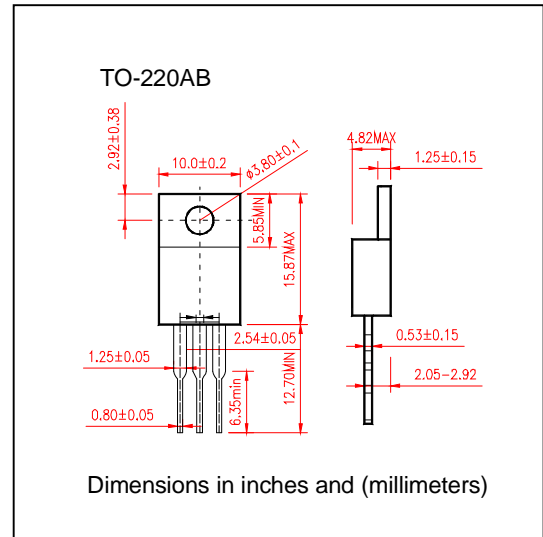

### MAXIMUM RATINGS AND ELECTRICAL CHARACTERISTICS

- Ratings at 25°C ambient temperature unless otherwise specified
- Single Phase, half wave, 60Hz, resistive or inductive load
- For capacitive load derate current by 20%

	SYMBOLS	SR16 20C	SR1 630C	SR1 635C	SR1 640C	SR1 645C	SR1 650C	SR1 660C	SR1 680C	SR161 00C	SR16 150C	SR16 200C	UNIT
Maximum Repetitive Peak Reverse Voltage	$V_{RRM}$	20	30	35	40	45	50	60	80	100	150	200	Volts
Maximum RMS Voltage	$V_{RMS}$	14	21	25	28	32	35	42	56	70	105	140	Volts
Maximum DC Blocking Voltage	$V_{DC}$	20	30	35	40	45	50	60	80	100	150	200	Volts
Maximum Average Forward Rectified Current At $T_c=90^\circ\text{C}$	$I_{(AV)}$	16.0											Amps
Peak Forward Surge Current 8.3ms single half sine wave superimposed on rated load (JEDEC method)	$I_{FSM}$	150											Amps
Maximum Forward Voltage at 8.0A per element	$V_F$	0.65					0.75			0.85			Volts
Maximum DC Reverse Current at rated DC Blocking Voltage per element	$T_C = 25^\circ\text{C}$	0.5											mA
	$T_C = 100^\circ\text{C}$	100											
Typical Junction Capacitance(Note2)	$C_J$	500											pF
Typical Thermal Resistance (Note 1)	$R_{\theta JC}$	2.0											$^\circ\text{C}/\text{W}$
Operating Storage Temperature Range	$T_J T_{STG}$	(-55 to +150)											$^\circ\text{C}$

#### Notes:

1. Thermal Resistance Junction to Case
2. Measured at  $V_R=4\text{v}$  and  $f=1\text{MHz}$



# SCHOTTKY BARRIER RECTIFIER

SR1620C THRU SR16100C

VOLTAGE RANGE 20 to 100 Volts  
CURRENT 16.0 Ampere

## RATING AND CHARACTERISTIC CURVES SR1620C THRU SR16100C

FIG.1-TYPICAL FORWARD CURRENT DERATING CURVE

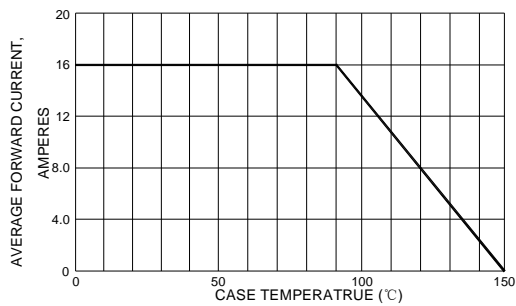

FIG.3-TYPICAL INSTANTANEOUS FORWARD CHARACTERISTIC

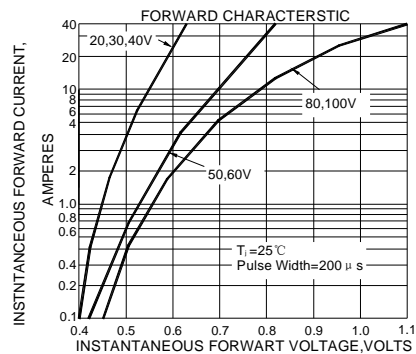

FIG.2-TYPICAL REVERSE CHARACTERISTICS

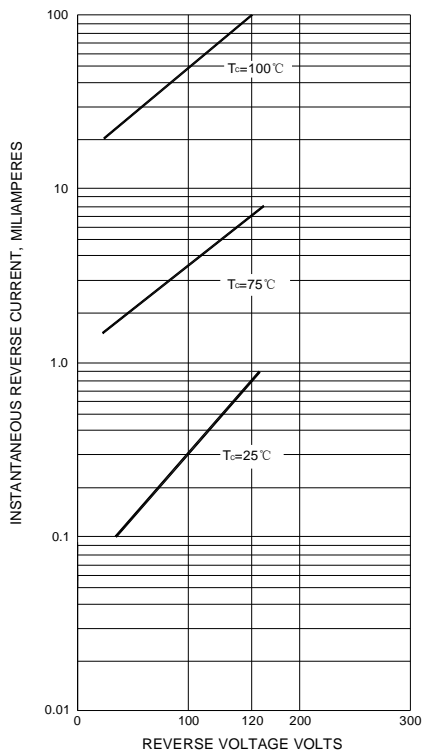

FIG.4-MAXIMUM NON-REPETITIVE SURGE CURRENT

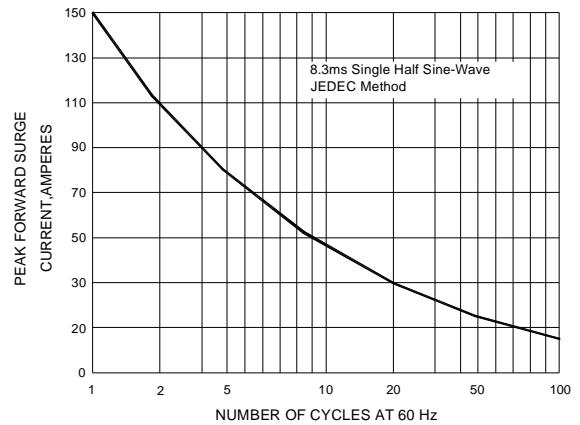

FIG.5-TYPICAL JUNCTION CAPACITANCE

