



SCHOTTKY BARRIER RECTIFIER

SR2020 THRU SR20100

VOLTAGE RANGE 20 to 100 Volts
CURRENT 20.0 Ampere

FEATURES

- Plastic package has Underwriters Laboratory Flammability Classification 94V-O utilizing Flame Retardant Epoxy Molding Compound
- Exceeds environmental standards of MIL-S-19500/228
- Low power loss, high efficiency
- Low forward voltage, high current capability
- High surge capacity
- For use in low voltage high frequency inverters, Free wheeling, and polarity protection applications

MECHANICAL DATA

- Case: TO-220AC molded plastic
- Terminals: Lead solderable per MIL-STD-202 Method 208
- Polarity: as marked
- Mounting position: Any
- Weight: 0.08ounce, 2.24 grams

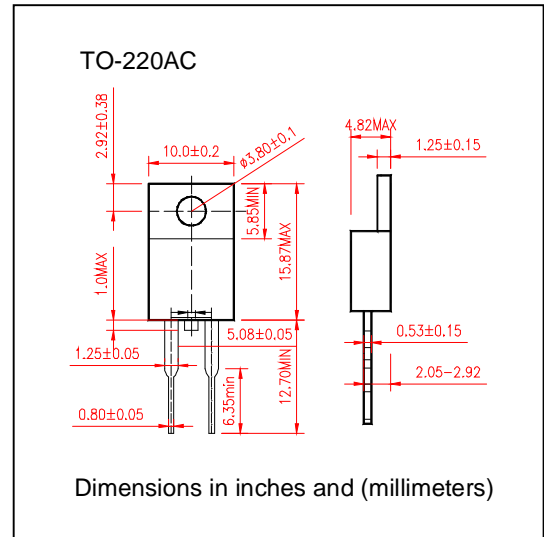

MAXIMUM RATINGS AND ELECTRICAL CHARACTERISTICS

- Ratings at 25°C ambient temperature unless otherwise specified
- Single Phase, half wave, 60Hz, resistive or inductive load
- For capacitive load derate current by 20%

	SYMBOLS	SR 2020	SR 2030	SR 2035	SR 2040	SR 2045	SR 2050	SR 2060	SR 2080	SR 20100	SR 20150	SR 20200	UNIT
Maximum Repetitive Peak Reverse Voltage	V_{RRM}	20	30	35	40	45	50	60	80	100	150	200	Volts
Maximum RMS Voltage	V_{RMS}	14	21	25	28	32	35	42	56	70	105	140	Volts
Maximum DC Blocking Voltage	V_{DC}	20	30	35	40	45	50	60	80	100	150	200	Volts
Maximum Average Forward Rectified Current At $T_c=100^\circ\text{C}$	$I_{(AV)}$	20.0											Amps
Peak Forward Surge Current 8.3ms single half sine wave superimposed on rated load (JEDEC method)	I_{FSM}	150											Amps
Maximum Forward Voltage at 20.0A per element	V_F	0.65				0.75			0.85				Volts
Maximum DC Reverse Current at rated DC Blocking Voltage per element	$T_c = 25^\circ\text{C}$	1.0											mA
	$T_c = 100^\circ\text{C}$	100											
Typical Junction Capacitance(Note2)	C_J	700											pF
Typical Thermal Resistance (Note 1)	$R_{\theta JC}$	2.0											$^\circ\text{C}/\text{W}$
Operating Storage Temperature Range	$T_J T_{STG}$	(-55 to +150)											$^\circ\text{C}$

Notes:

1. Thermal Resistance Junction to CASE
2. Measured at $V_R=4\text{V}$ and $f=1\text{MHz}$



SCHOTTKY BARRIER RECTIFIER

SR2020 THRU SR20100

VOLTAGE RANGE 20 to 100 Volts
CURRENT 20.0 Amperes

RATING AND CHARACTERISTIC CURVES SR12020 THRU SR20100

