



SCHOTTKY BARRIER RECTIFIER

SR2020C THRU SR20100C

VOLTAGE RANGE 20 to 100 Volts
CURRENT 20.0 Amperes

FEATURES

- Plastic package has Underwriters Laboratory Flammability Classification 94V-O utilizing Flame Retardant Epoxy Molding Compound
- Exceeds environmental standards of MIL-S-19500/228
- Low power loss, high efficiency
- Low forward voltage, high current capability
- High surge capacity
- For use in low voltage high frequency inverters, Free wheeling, and polarity protection applications

MECHANICAL DATA

- Case: TO-220AB molded plastic
- Terminals: Lead solderable per MIL-STD-202 Method 208
- Polarity: as marked
- Mounting position: Any
- Weight: 0.08ounce, 2.24 grams

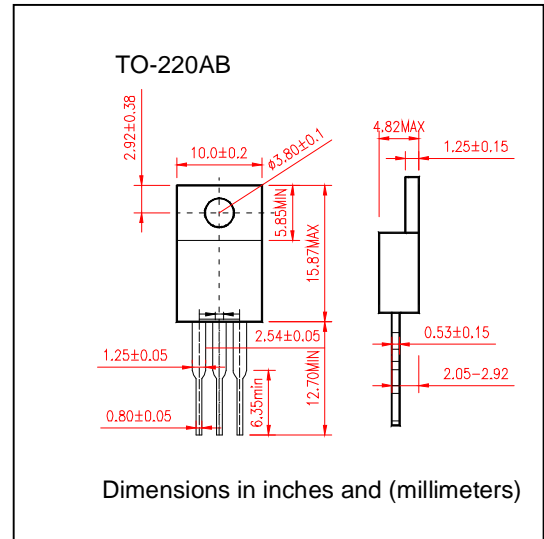

MAXIMUM RATINGS AND ELECTRICAL CHARACTERISTICS

- Ratings at 25°C ambient temperature unless otherwise specified
- Single Phase, half wave, 60Hz, resistive or inductive load
- For capacitive load derate current by 20%

	SYMBOLS	SR 2020C	SR 2030C	SR 2035C	SR 2040C	SR 2045C	SR 2050C	SR 2060C	SR 2080C	SR ₂₀ 100C	SR ₂₀ 150C	SR ₂₀ 200C	UNIT	
Maximum Repetitive Peak Reverse Voltage	V _{RRM}	20	30	35	40	45	50	60	80	100	150	200	Volts	
Maximum RMS Voltage	V _{RMS}	14	21	25	28	32	35	42	56	70	105	140	Volts	
Maximum DC Blocking Voltage	V _{DC}	20	30	35	40	45	50	60	80	100	150	200	Volts	
Maximum Average Forward Rectified Current At T _c =100°C	I _(AV)	20.0											Amps	
Peak Forward Surge Current 8.3ms single half sine wave superimposed on rated load (JEDEC method)	I _{FSM}	150											Amps	
Maximum Forward Voltage at 20.0A per element	V _F	0.65				0.75				0.85				Volts
Maximum DC Reverse Current at rated DC Blocking Voltage per element	I _R	1.0											mA	
		100												
Typical Junction Capacitance(Note2)	C _J	700											pF	
Typical Thermal Resistance (Note 1)	R _{θJC}	2.0											°C/W	
Operating Storage Temperature Range	T _J T _{STG}	(-55 to +150)											°C	

Notes:

1. Thermal Resistance Junction to CASE
2. Measured at V_R=4V and f=1MHz



SCHOTTKY BARRIER RECTIFIER

SR2020C THRU SR20100C

VOLTAGE RANGE 20 to 100 Volts
CURRENT 20.0 Ampere

RATING AND CHARACTERISTIC CURVES SR12020C THRU SR20100C

FIG.1-TYPICAL FORWARD CURRENT DERATING CURVE

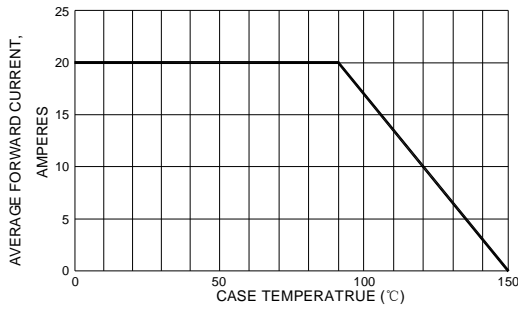

FIG.3-TYPICAL INSTANTANEOUS FORWARD CHARACTERISTIC

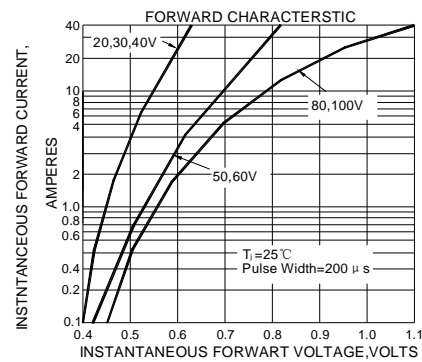

FIG.2-TYPICAL REVERSE CHARACTERISTICS

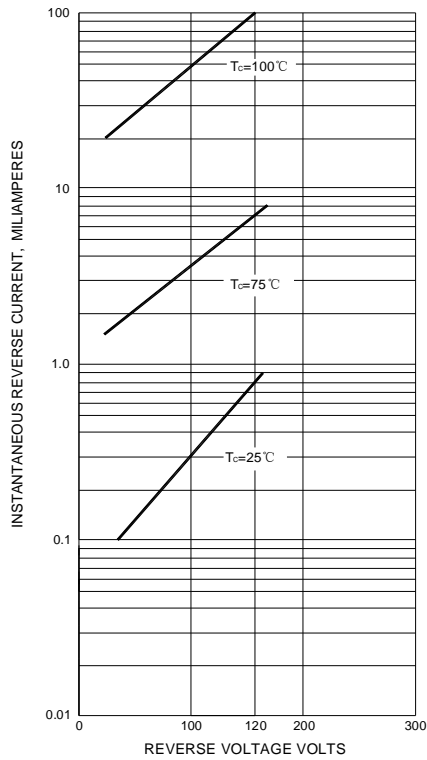

FIG.4-MAXIMUM NON-REPETITIVE SURGE CURRENT

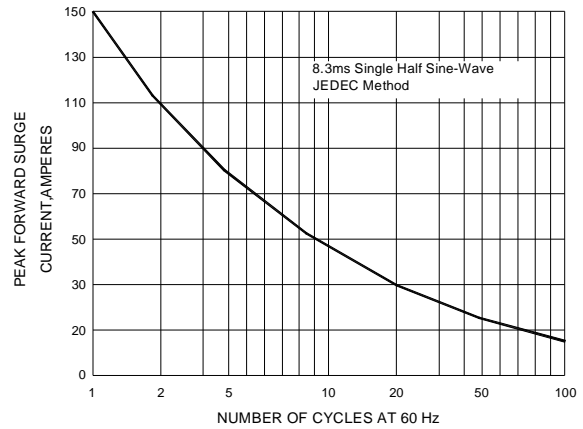

FIG.5-TYPICAL JUNCTION CAPACITANCE

