



SCHOTTKY BARRIER RECTIFIER

SR3020C THRU SR30200C

VOLTAGE RANGE

20 to 200 Volts

CURRENT

30.0 Amperes

FEATURES

- Plastic package has Underwriters Laboratory Flammability Classification 94V-O utilizing Flame Retardant Epoxy Molding Compound
- Exceeds environmental standards of MIL-S-19500/228
- Low power loss, high efficiency
- Low forward voltage, high current capability
- High surge capacity
- For use in low voltage high frequency inverters, Free wheeling, and polarity protection applications

MECHANICAL DATA

- Case: TO-220AB molded plastic
- Terminals: Lead solderable per MIL-STD-202 Method 208
- Polarity: as marked
- Mounting position: Any
- Weight: 0.08ounce, 2.24 grams

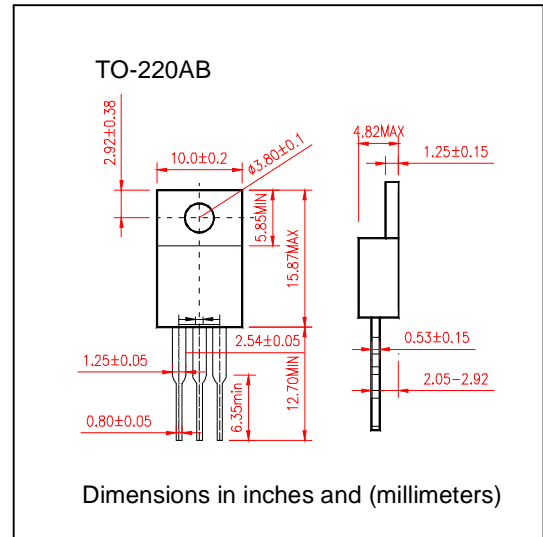

MAXIMUM RATINGS AND ELECTRICAL CHARACTERISTICS

- Ratings at 25°C ambient temperature unless otherwise specified
- Single Phase, half wave, 60Hz, resistive or inductive load
- For capacitive load derate current by 20%

	SYMBOLS	SR 3020 C	SR 3030 C	SR 3035 C	SR 3040 C	SR 3045 C	SR 3050 C	SR 3060 C	SR 3080 C	SR 30100 C	SR 30150 C	SR 30200 C	UNIT	
Maximum Repetitive Peak Reverse Voltage	V_{RRM}	20	30	35	40	45	50	60	80	100	150	200	Volts	
Maximum RMS Voltage	V_{RMS}	14	21	25	28	32	35	42	56	70	105	140	Volts	
Maximum DC Blocking Voltage	V_{DC}	20	30	35	40	45	50	60	80	100	150	200	Volts	
Maximum Average Forward Rectified Current At $T_C=90^\circ\text{C}$	$I_{(AV)}$	30.0											Amps	
Peak Forward Surge Current 8.3ms single half sine wave superimposed on rated load (JEDEC method)	I_{FSM}	200											Amps	
Maximum Forward Voltage at 15.0A per element	V_F	0.65			0.72			0.75			0.85			Volts
Maximum DC Reverse Current at rated DC Blocking Voltage per element	I_R	$T_C = 25^\circ\text{C}$											mA	
		$T_C = 100^\circ\text{C}$												
Typical Junction Capacitance(Note2)	C_J	500											pF	
Typical Thermal Resistance (Note 1)	$R_{\theta JC}$	2.0											$^\circ\text{C}/\text{W}$	
Operating Storage Temperature Range	$T_J T_{STG}$	(-55 to +150)											$^\circ\text{C}$	

Notes:

1. Thermal Resistance Junction to Ambient
2. Measured at $V_R=4\text{V}$ and $f=1\text{MHz}$



SCHOTTKY BARRIER RECTIFIER

SR3020CTHRU SR30200C

VOLTAGE RANGE 20 to 200 Volts
CURRENT 16.0 Amperes

RATING AND CHARACTERISTIC CURVES SR3020C THRU SR30100C

FIG.1-TYPICAL FORWARD CURRENT DERATING CURVE

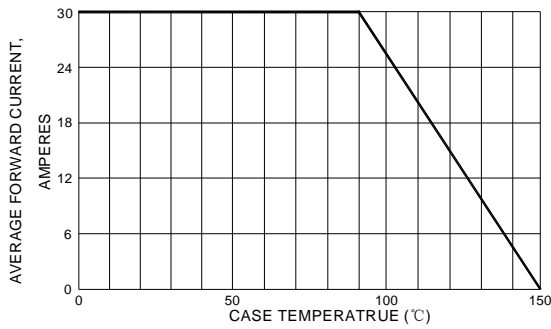

FIG.3-TYPICAL INSTANTANEOUS FORWARD CHARACTERISTIC

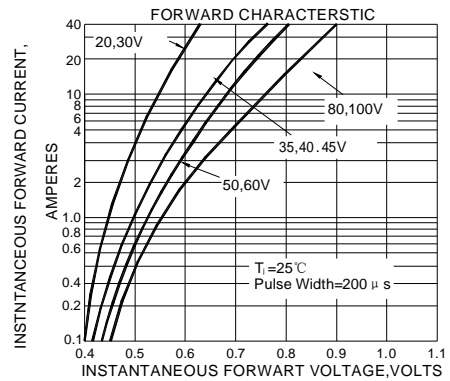

FIG.2-TYPICAL REVERSE CHARACTERISTICS

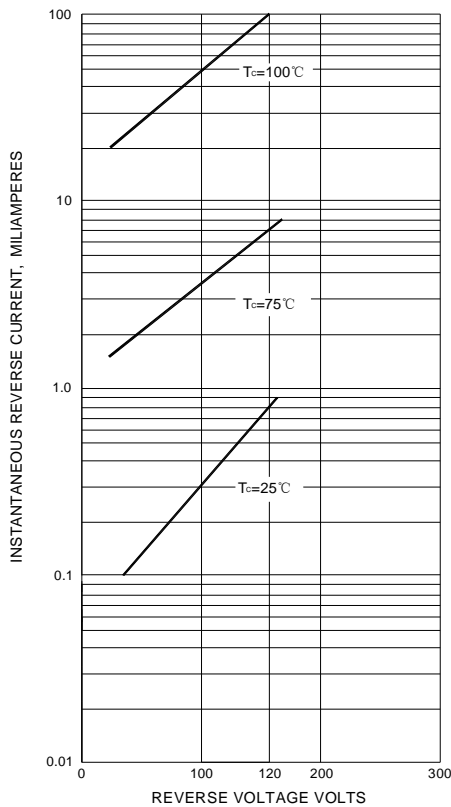

FIG.4-MAXIMUM NON-REPETITIVE SURGE CURRENT

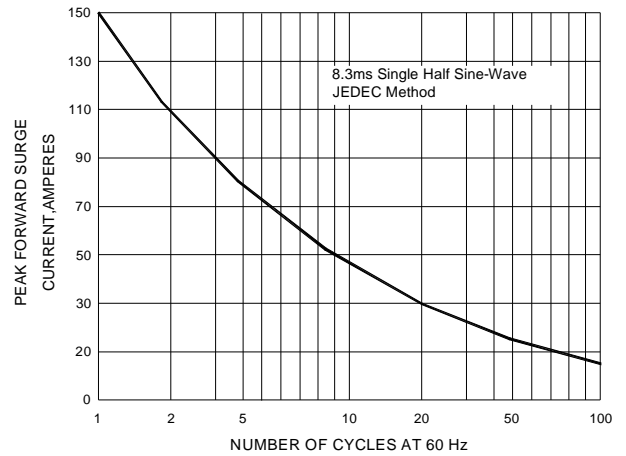

FIG.5-TYPICAL JUNCTION CAPACITANCE

