



## LOW FORWARD VOLTAGE SCHOTTKY BARRIER RECTIFIER

### SRL5030P THRU SRL5060P

**VOLTAGE RANGE**      30 to 60 Volts  
**CURRENT**              50.0 Amperes

### FEATURES

- Schottky Barrier Chip
- Guard Ring Die Construction for Transient Protection
- Low Power Loss, High efficiency
- High Surge Capability
- High Current capacity and Low Forward Voltage Drop
- For use in low voltage high frequency inverters, Free wheeling, and polarity protection applications
- Plastic Material has UL Flammability Classification 94V-0

### MECHANICAL DATA

- Case: TO-3P(TO-247AD) molded plastic
- Terminals: Plated Lead solderable per MIL-STD-202 Method 208
- Polarity: See Diagram
- Weight: 5.6 grams (approx)
- Mounting Position: Any
- Marking: Type Number

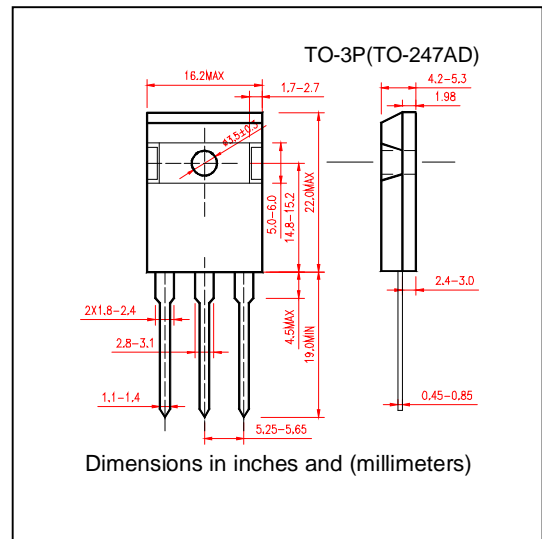

### MAXIMUM RATINGS AND ELECTRICAL CHARACTERISTICS

- Single Phase, half wave, 60Hz, resistive or inductive load
- For capacitive load derate current by 20%

	SYMBOLS	SRL 5030P	SRL 5035P	SRL 5040P	SRL 5045P	SRL 5050P	SRL 5060P	UNIT
Peak Repetitive Reverse Voltage	$V_{RRM}$	30	35	40	45	50	60	V
Working Peak Reverse Voltage	$V_{RWM}$							
DC Blocking Voltage	$V_R$							
RMS Reverse Voltage	$V_{R(RMS)}$	21	25	28	32	35	42	V
Average Rectified Output Current (Note 1)@ $T_c=95^\circ C$	$I_O$	50.0						A
Non-Repetitive Peak Forward Surge Current 8.3ms single half sine wave superimposed on rated load (JEDEC method)	$I_{FSM}$	400						A
Forward Voltage Drop @ $I_F=25A, T_c=25^\circ C$	$V_{FM}$	0.55				0.65		V
Peak Reverse Current at Rated DC Blocking Voltage	$T_c = 25^\circ C$	5.0						mA
	$T_c = 100^\circ C$	150						
Typical Junction Capacitance(Note2)	$C_j$	1000						pF
Typical Resistance Junction to case(Note1)	$R_{\theta JC}$	2.0						$^\circ C/W$
Operating and Storage Temperature Range	$T_j T_{STG}$	(-55 to +150)						$^\circ C$

#### Notes:

1. Thermal Resistance Junction to case mounted on heatsink
2. Measured at 1.0MHz and applied reverse voltage of 4.0V DC



# LOW FORWARD VOLTAGE SCHOTTKY BARRIER RECTIFIER

**SRL5030P THRU SRL5060P**

**VOLTAGE RANGE** 30 to 60 Volts  
**CURRENT** 50.0 Amperes

## RATING AND CHARACTERISTIC CURVES SRL5030P THRU SRL5060P

FIG.1-FORWARD CURRENT DERATING CURVE

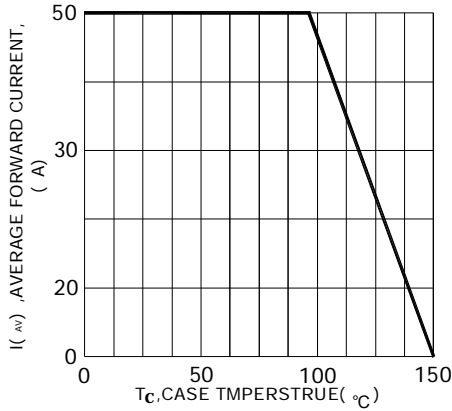

FIG.2-TYPICAL FORWARD CHARACTERISTICS

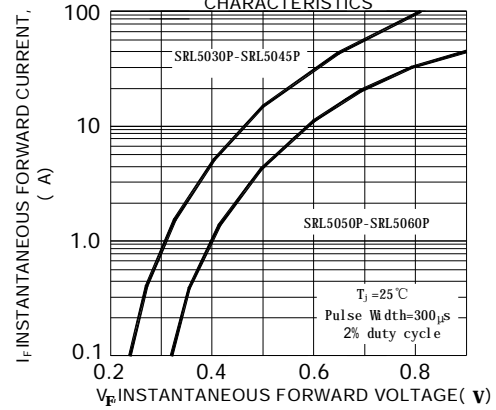

FIG.3 MAX NON-REPETITIVE SURGE CURRENT

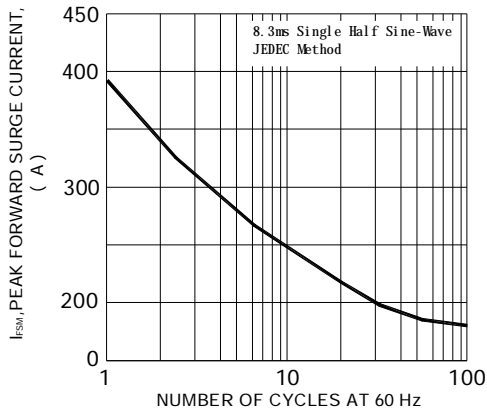

FIG4 TYPICAL JUNCTION CAPACITANCE PER ELEMENT

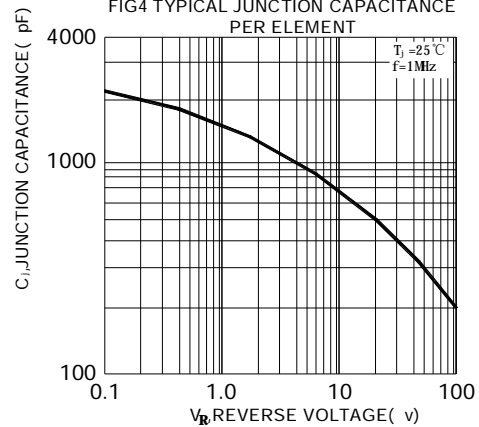

FIG.5-TYPICAL REVERSE CHARACTERISTICS

