

MITSUBISHI GENERAL USE THYRISTORS

FT1500AU-240

HIGH VOLTAGE, HIGH POWER, GENERAL USE
DYNAMIC GATE, PRESS PACK TYPE

FT1500AU-240



- IT(AV) Average on-state current 1500A
- VDRM Repetitive peak off state voltage 12000V
- Press pack type

OUTLINE DRAWING

Dimension in mm

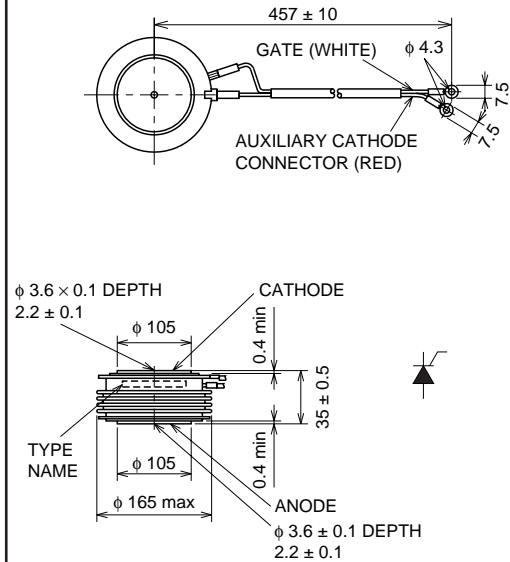

APPLICATION

AC switch for high voltage line, SVC

www.BDTIC.com/MITSUBISHI

ABSOLUTE MAXIMUM RATINGS

Symbol	Parameter	Voltage class		Unit
		240		
VRRM	Repetitive peak reverse voltage	12000		V
VRSM	Non-repetitive peak reverse voltage	12000		V
VR(DC)	DC reverse voltage	9600		V
VDRM	Repetitive peak off-state voltage	12000		V
VD SM	Non-repetitive peak off-state voltage	12000		V
VD(DC)	DC off-state voltage	9600		V

Symbol	Parameter	Conditions	Ratings	Unit
IT(RMS)	RMS on-state current		2360	A
IT(AV)	Average on-state current	f = 60Hz, sine wave $\theta = 180^\circ$, $T_f = 88^\circ\text{C}$	1500	A
ITSM1	Surge on-state current	One half cycle at 60Hz	34	kA
ITSM2	Surge on-state current 2	One half cycle ($t_w = 12\text{ms}$), $T_j = 125^\circ\text{C}$ start $V_{FP} = 6\text{kV}$, $V_{RP} = 6\text{kV}$	28	kA
I^2t	Current-squared, time integration	One cycle at 60Hz	4.8×10^6	A^2s
diT/dt	Critical rate of rise of on-state current	$V_D = 1/2V_{DRM}$, $I_G = 2.0\text{A}$, $di_G/dt = 1.5\text{A}/\mu\text{s}$, $T_j = 125^\circ\text{C}$	100	$\text{A}/\mu\text{s}$
PFGM	Peak forward gate power dissipation		30	W
PFG(AV)	Average forward gate power dissipation		8.0	W
VFGM	Peak forward gate voltage		20	V
VRGM	Peak reverse gate voltage		10	V
IFGM	Peak forward gate current		6.0	A
T_j	Junction temperature		-40 ~ +125	$^\circ\text{C}$
T_{stg}	Storage temperature		-40 ~ +150	$^\circ\text{C}$
—	Mounting force required	Recommended value 118	108 ~ 132	kN
—	Weight	Standard value	4000	g

Feb.1999

FT1500AU-240

HIGH VOLTAGE, HIGH POWER, GENERAL USE
DYNAMIC GATE, PRESS PACK TYPE

ELECTRICAL CHARACTERISTICS

Symbol	Parameter	Test conditions	Limits			Unit
			Min	Typ	Max	
I _{RRM}	Repetitive peak reverse current	T _j = 125°C, V _{RRM} Applied	—	—	1200	mA
I _{DRM}	Repetitive peak off-state current	T _j = 125°C, V _{DRM} Applied	—	—	1200	mA
V _{TM}	On-state voltage	T _j = 125°C, I _{TM} = 3000A, Instantaneous measurement	—	—	4.0	V
dv/dt	Critical rate of rise of off-state voltage	T _j = 125°C, V _D = 1/2V _{DRM}	2000	—	—	V/μs
V _{GT}	Gate trigger voltage	T _j = 25°C, V _D = 6V, R _L = 2Ω	—	—	2.5	V
V _{GD}	Gate non-trigger voltage	T _j = 125°C, V _D = 1/2V _{DRM}	0.2	—	—	V
I _{GT}	Gate trigger current	T _j = 25°C, V _D = 6V, R _L = 2Ω	—	—	350	mA
R _{th(j-f)}	Thermal resistance	Junction to fin	—	—	0.005	°C/W

PERFORMANCE CURVES

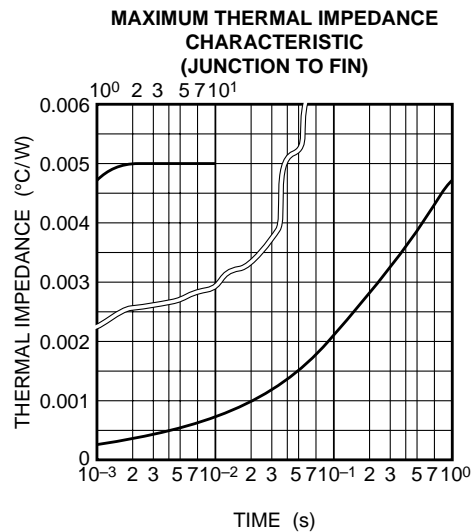
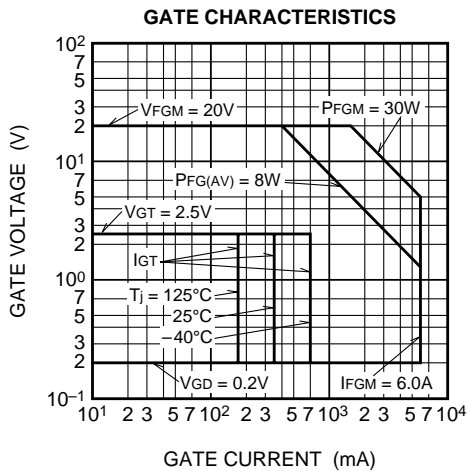
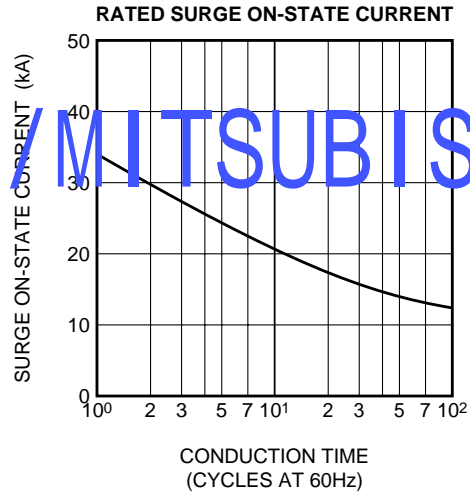
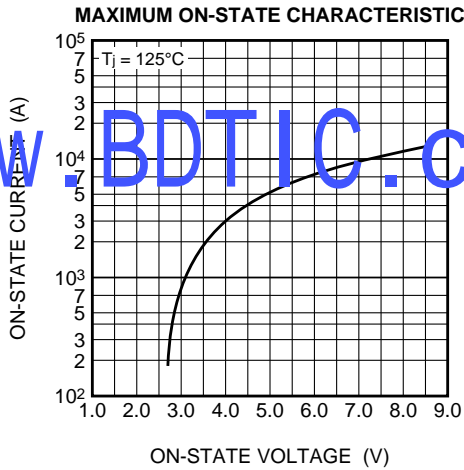

FT1500AU-240

HIGH VOLTAGE, HIGH POWER, GENERAL USE
DYNAMIC GATE, PRESS PACK TYPE

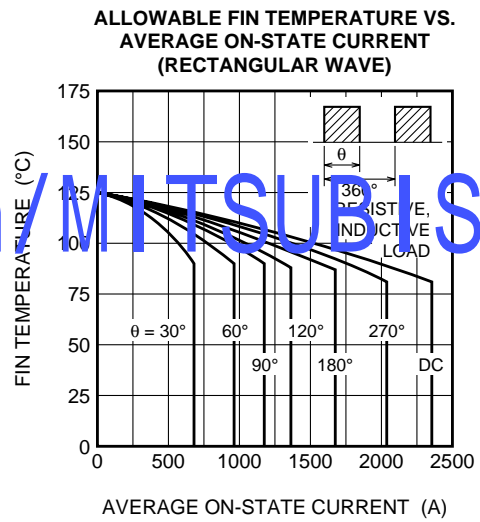
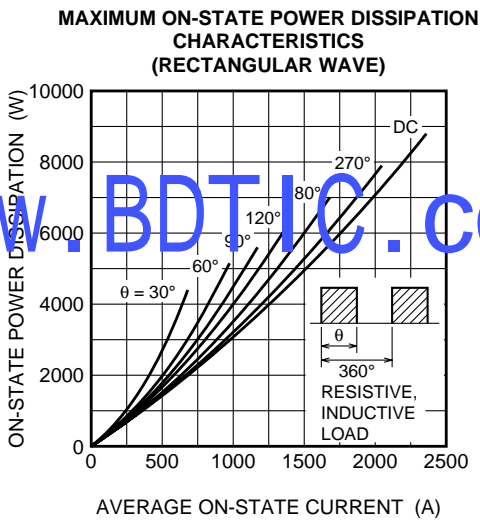
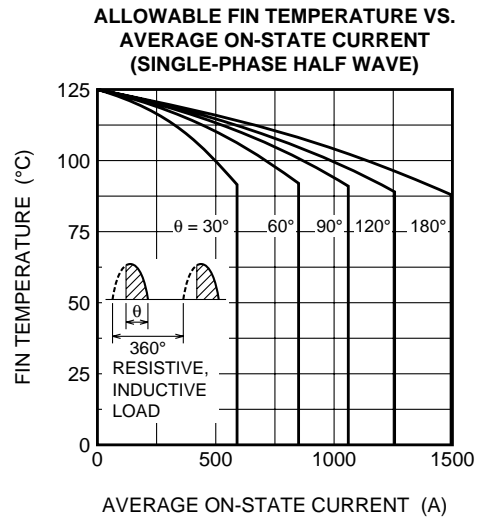
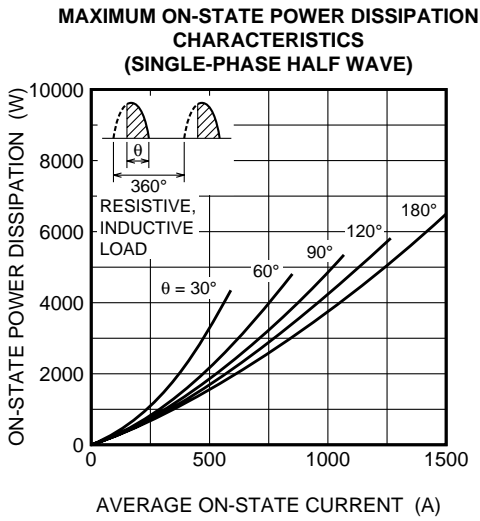

www.BDTIC.com/MITSUBISHI

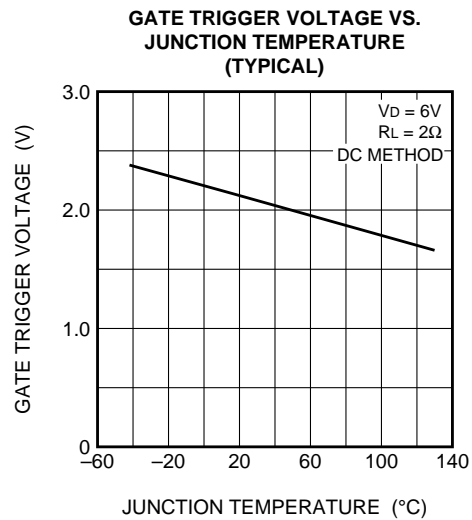
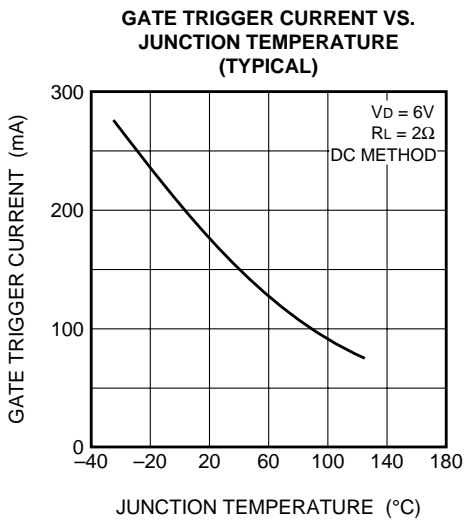

FT1500AU-240

HIGH VOLTAGE, HIGH POWER, GENERAL USE
DYNAMIC GATE, PRESS PACK TYPE

HOLDING CURRENT LATCHING CURRENT VS. JUNCTION TEMPERATURE (TYPICAL)

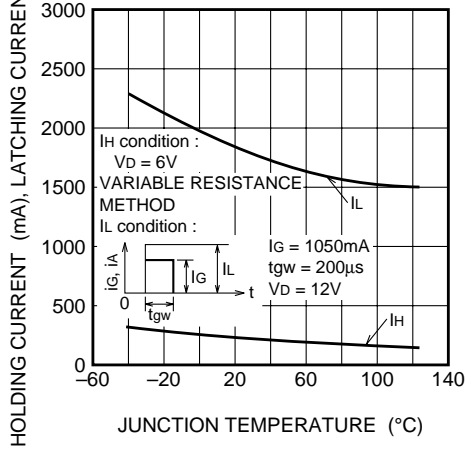

TURN-ON TIME VS. GATE CURRENT (TYPICAL)

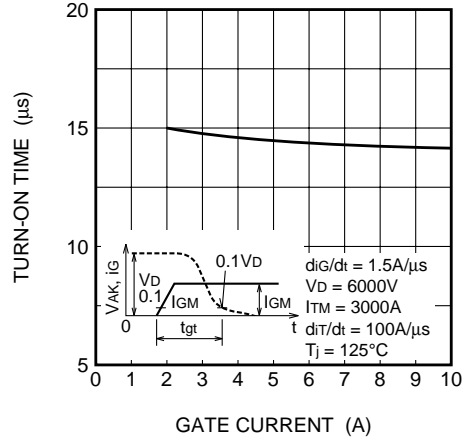

TURN-OFF TIME VS. JUNCTION TEMPERATURE (TYPICAL)

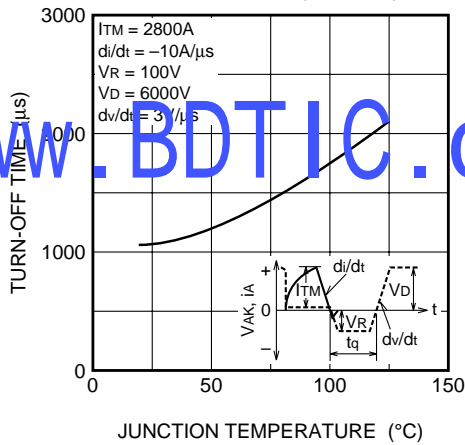

TURN-OFF TIME VS. RATE OF RISE OF OFF-STATE VOLTAGE (TYPICAL)

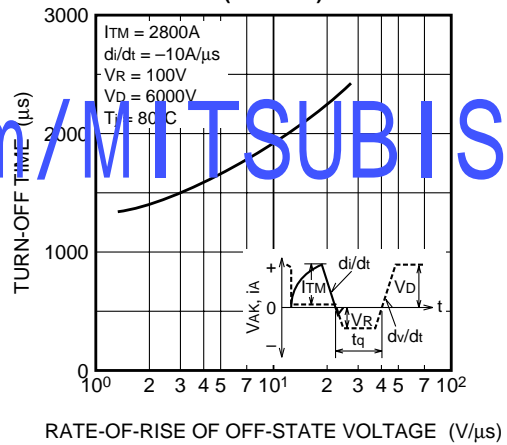

REVERSE RECOVERED CHARGE VS. JUNCTION TEMPERATURE (TYPICAL)

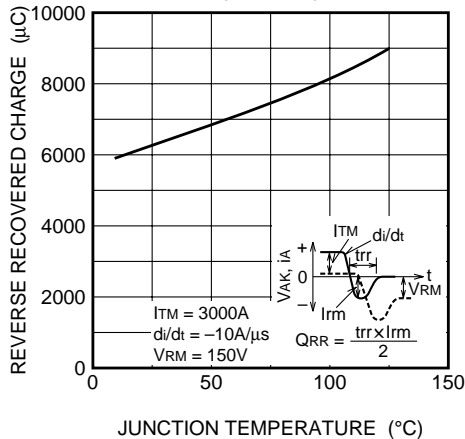

REVERSE RECOVERED CHARGE VS. RATE OF DECREASE OF ON-STATE CURRENT (TYPICAL)

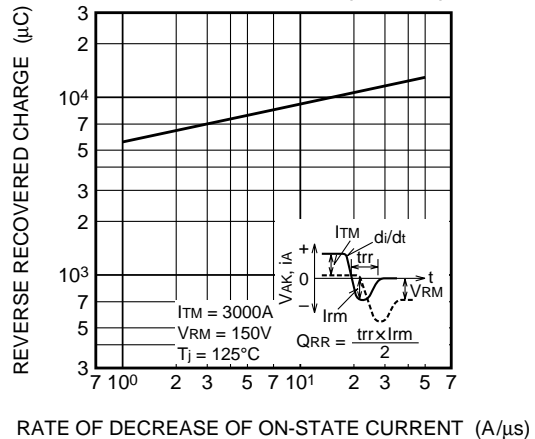

www.BDTIC.com/MITSUBISHI