

M54513P/FP

8-UNIT 50mA TRANSISTOR ARRAY

DESCRIPTION

M54513P and M54513FP are eight-circuit transistor arrays. The circuits are made of NPN transistors. Both the semiconductor integrated circuits perform high-current driving with extremely low input-current supply.

FEATURES

- High breakdown voltage ($BV_{CEO} \geq 40V$)
- Synchronizing current ($I_c(max) = 50mA$)
- Wide operating temperature range ($T_a = -20$ to $+75^\circ C$)

APPLICATION

Driving of digit drives of indication elements (LEDs and lamps) with small signals

FUNCTION

The M54513P and M54513FP each have eight circuits consisting of NPN transistors. These ICs have resistance of 2 k Ω at inputs and of 13.6k Ω between the base and emitter. The GND is used in common in each circuit.

The transistors allow synchronous flow of 50mA collector current. A maximum of 40V voltage can be applied between the collector and emitter.

The M54513FP is enclosed in a molded small flat package, enabling space-saving design.

PIN CONFIGURATION

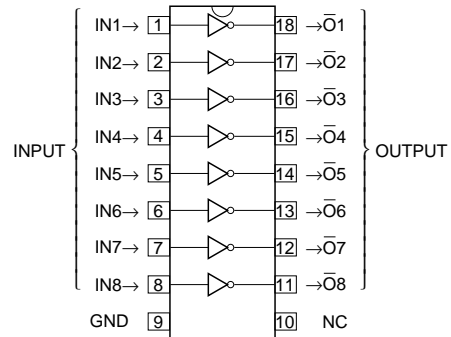

Package type 18P4G(P) NC : No connection

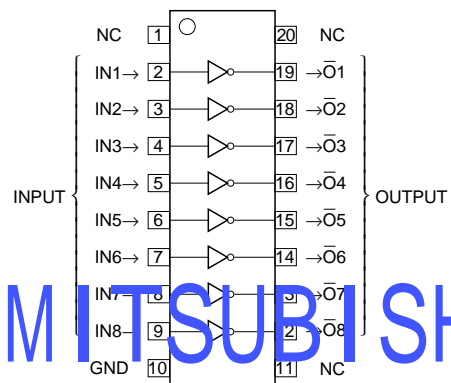

Package type 20P2N-A(FP) NC : No connection

CIRCUIT DIAGRAM

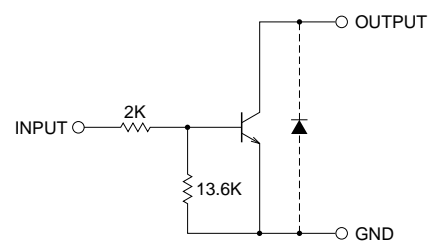

The eight circuits share the GND.

The diode, indicated with the dotted line, is parasitic, and cannot be used.

Unit : Ω

www.BDTIC.com/MITSUBISHI

M54513P/FP

8-UNIT 50mA TRANSISTOR ARRAY

ABSOLUTE MAXIMUM RATINGS (Unless otherwise noted, Ta = -20 ~ +75°C)

Symbol	Parameter	Conditions	Ratings	Unit
V _{CEO}	Collector-emitter voltage	Output, H	-0.5 ~ +40	V
I _C	Collector current	Current per circuit output, L	50	mA
V _I	Input voltage		-0.5 ~ +10	V
P _d	Power dissipation	Ta = 25°C, when mounted on board	1.79(P)/1.10(FP)	W
T _{opr}	Operating temperature		-20 ~ +75	°C
T _{stg}	Storage temperature		-55 ~ +125	°C

RECOMMENDED OPERATING CONDITIONS (Unless otherwise noted, Ta = -20 ~ +75°C)

Symbol	Parameter	Limits			Unit
		min	typ	max	
V _O	Output voltage	0	—	40	V
I _C	Collector current	0	—	30	mA
V _{IH}	"H" input voltage	2	—	8	V
V _{IL}	"L" input voltage	0	—	0.2	V

ELECTRICAL CHARACTERISTICS (Unless otherwise noted, Ta = -20 ~ +75°C)

Symbol	Parameter	Test conditions	Limits			Unit
			min	typ*	max	
V (BR) CEO	Collector-emitter breakdown voltage	I _{CEO} = 100μA	40	—	—	V
V _{CE(sat)}	Collector-emitter saturation voltage	V _I = 2V, I _C = 10mA	—	25	100	mV
I _I	Input current	V _I = 2.5V, I _C = 30mA	—	70	170	μA
h _{FE}	DC amplification factor	V _I = 2.5V, V _{CE} = 4V, I _C = 30mA, Ta = 25°C	80	200	—	—

* : The typical values are those measured under ambient temperature (Ta) of 25°C. There is no guarantee that these values are obtained under any conditions.

SWITCHING CHARACTERISTICS (Unless otherwise noted, Ta = 25°C)

Symbol	Parameter	Test conditions	Limits			Unit
			min	typ	max	
t _{on}	Turn-on time	C _L = 15pF (note 1)	—	65	—	ns
t _{off}	Turn-off time		—	1200	—	ns

NOTE 1 TEST CIRCUIT

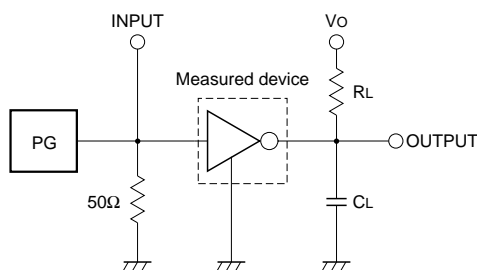

- (1) Pulse generator (PG) characteristics : PRR = 1kHz, tw = 10μs, tr = 6ns, tf = 6ns, ZO = 50Ω, VP = 2.5VP-P
- (2) Output conditions : RL = 300Ω, VO = 10V
- (3) Electrostatic capacity CL includes floating capacitance at connections and input capacitance at probes

TIMING DIAGRAM

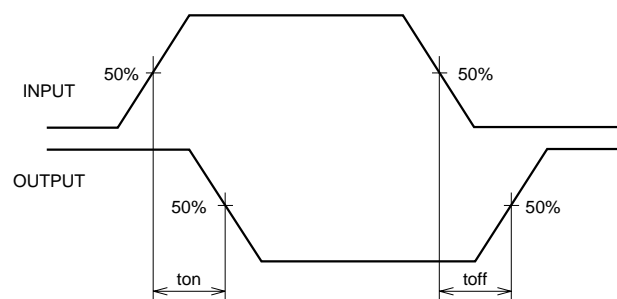

TYPICAL CHARACTERISTICS

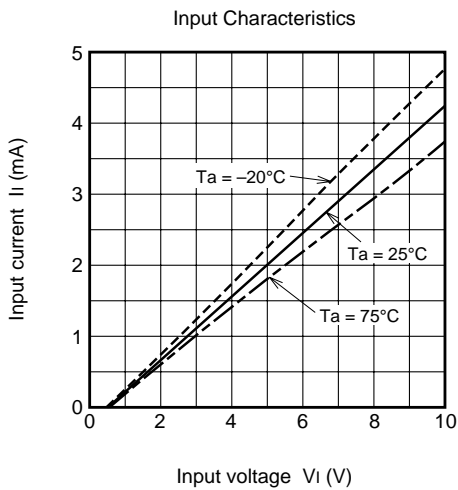
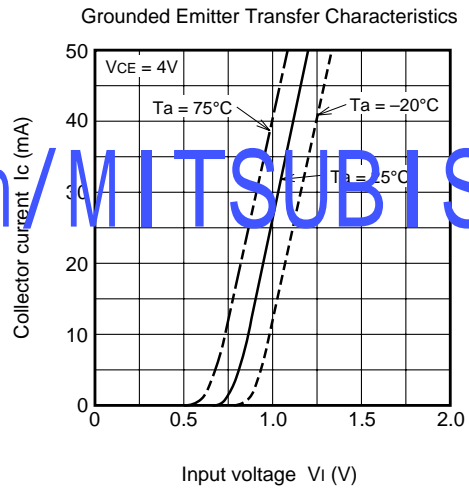
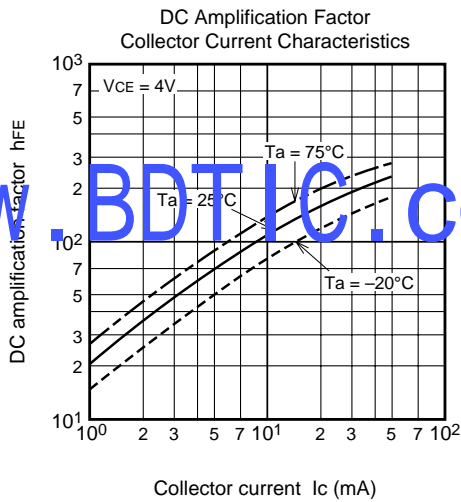
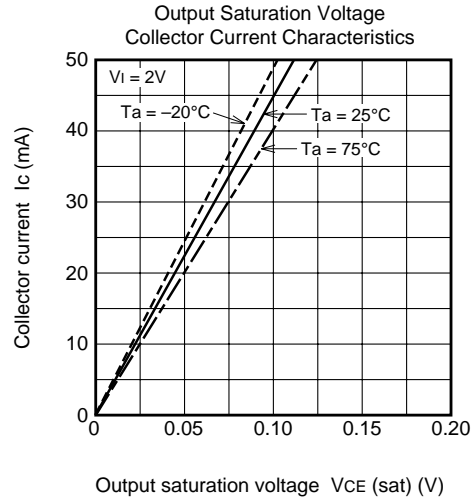
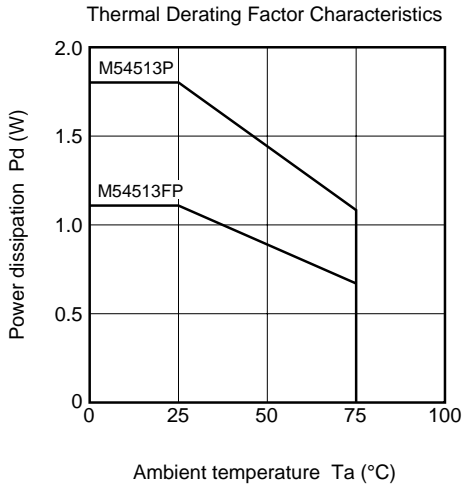

www.BDTIC.com/MITSUBISHI