

# M54532P/FP

4-UNIT 1.5A DARLINGTON TRANSISTOR ARRAY WITH CLAMP DIODE

## DESCRIPTION

M54532P and M54532FP are four-circuit Darlington transistor arrays with clamping diodes. The circuits are made of NPN transistors. Both the semiconductor integrated circuits perform high-current driving with extremely low input-current supply.

## FEATURES

- High breakdown voltage ( $BV_{CEO} \geq 50V$ )
- High-current driving ( $I_{c(max)} = 1.5A$ )
- With clamping diodes
- Wide operating temperature range ( $T_a = -20$  to  $+75^\circ C$ )

## APPLICATION

Drives of relays and printers, digit drives of indication elements (LEDs and lamps), and power amplification

## FUNCTION

The M54532P and M54532FP each have four circuits consisting of NPN Darlington transistors. They have resistance of  $340\Omega$  between input transistor bases and input pins. A clamping diode is provided between each output pin (collector) and COM pin. The output transistor emitters are all connected to the GND pin.

The collector current is 1.5A maximum. Collector-emitter supply voltage is 50V maximum.

The M54532FP is enclosed in a molded small flat package, enabling space-saving design.

## PIN CONFIGURATION

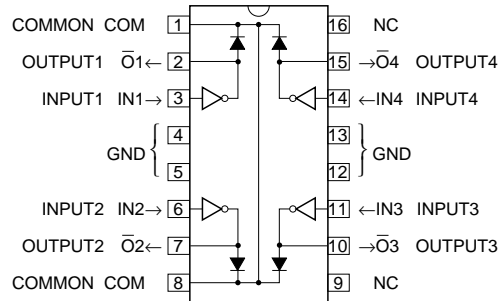

16P4(P)  
Package type 16P2N-A(FP) NC : No connection

## CIRCUIT DIAGRAM

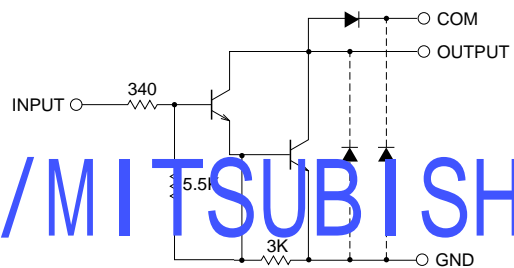

The four circuits share the COM and GND.  
The diode, indicated with the dotted line, is parasitic, and cannot be used.

Unit :  $\Omega$

## ABSOLUTE MAXIMUM RATINGS (Unless otherwise noted, $T_a = -20 \sim +75^\circ C$ )

Symbol	Parameter	Conditions	Ratings	Unit
$V_{CEO}$	Collector-emitter voltage	Output, H	$-0.5 \sim +50$	V
$I_C$	Collector current	Current per circuit output, L	1.5	A
$V_I$	Input voltage		$-0.5 \sim +10$	V
$V_R$	Clamping diode reverse voltage		50	V
$I_F$	Clamping diode forward current	Pulse Width $\leq 10ms$ , Duty Cycle $\leq 5\%$	1.5	A
		Pulse Width $\leq 100ms$ , Duty Cycle $\geq 5\%$	1.25	
$P_d$	Power dissipation	$T_a = 25^\circ C$ , when mounted on board	1.92(P)/1.00(FP)	W
$T_{opr}$	Operating temperature		$-20 \sim +75$	$^\circ C$
$T_{stg}$	Storage temperature		$-55 \sim +125$	$^\circ C$

**M54532P/FP**

4-UNIT 1.5A DARLINGTON TRANSISTOR ARRAY WITH CLAMP DIODE

**RECOMMENDED OPERATING CONDITIONS** (Unless otherwise noted, Ta = -20 ~ +75°C)

Symbol	Parameter	Limits			Unit	
		min	typ	max		
Vo	Output voltage	0	—	50	V	
Ic	Collector current (Current per 1 circuit when 4 circuits are coming on simultaneously)	Duty Cycle P : no more than 4% FP : no more than 2%	0	—	1.25	A
		Duty Cycle P : no more than 18% FP : no more than 9%	0	—	0.7	
VIH	"H" input voltage	3	—	6	V	
VIL	"L" input voltage	0	—	0.4	V	

**ELECTRICAL CHARACTERISTICS** (Unless otherwise noted, Ta = -20 ~ +75°C)

Symbol	Parameter	Test conditions	Limits			Unit
			min	typ*	max	
V (BR) CEO	Collector-emitter breakdown voltage	ICEO = 100μA	50	—	—	V
VCE (sat)	Collector-emitter saturation voltage	II = 2mA, IC = 1.25A	—	1.3	2.2	V
		II = 2mA, IC = 0.7A	—	1.1	1.7	
II	Input current	VI = 3V	—	5	8.5	mA
IR	Clamping diode reverse current	VR = 50V	—	—	100	μA
VF	Clamping diode forward voltage	IF = 1.25A	—	1.6	2.3	V
hFE	DC amplification factor	VCE = 4V, IC = 1A, Ta = 25°C	800	7000	—	—

\* : The typical values are those measured under ambient temperature (Ta) of 25°C. There is no guarantee that these values are obtained under any conditions.

**SWITCHING CHARACTERISTICS** (Unless otherwise noted, Ta = 25°C)

Symbol	Parameter	Test conditions	Limits			Unit
			min	typ	max	
ton	Turn-on time	CL = 15pF (note 1)	—	10	—	ns
toff	Turn-off time		—	500	—	ns

**NOTE 1 TEST CIRCUIT**

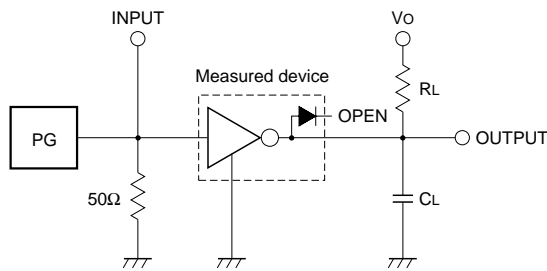

- (1) Pulse generator (PG) characteristics : PRR = 1kHz, tw = 10μs, tr = 6ns, tf = 6ns, Zo = 50Ω, VP = 3VP-P
- (2) Input-output conditions : RL = 8.3Ω, Vo = 10V
- (3) Electrostatic capacity CL includes floating capacitance at connections and input capacitance at probes

**TIMING DIAGRAM**

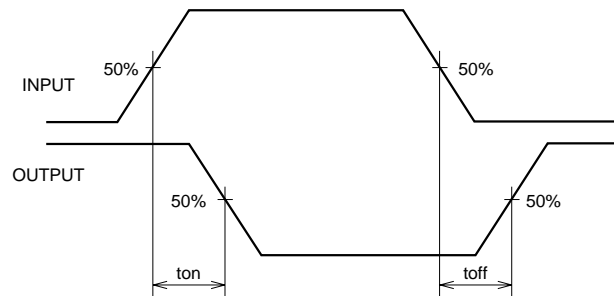

TYPICAL CHARACTERISTICS

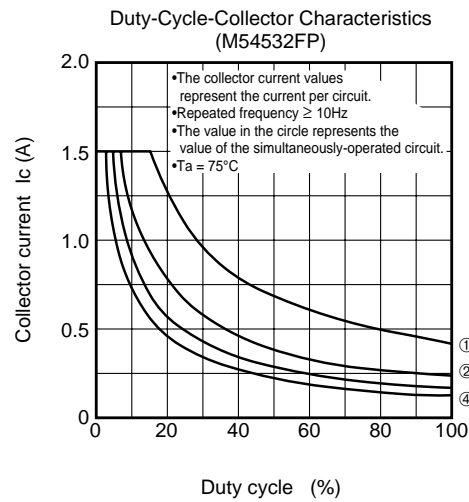
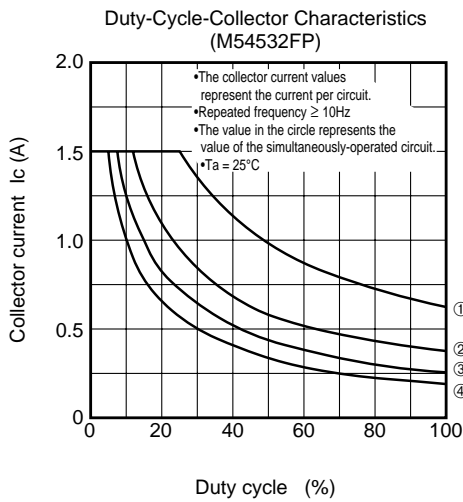
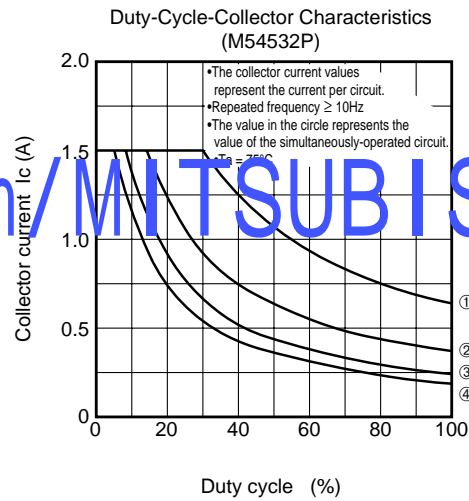
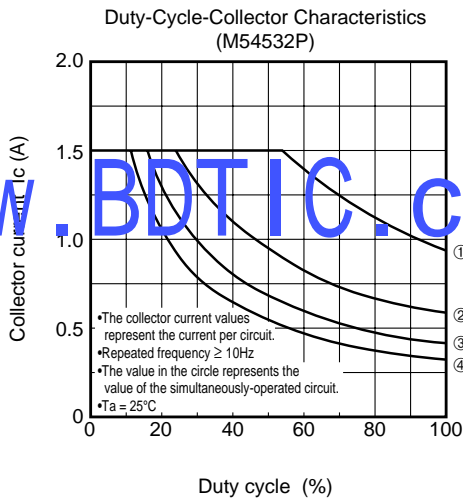
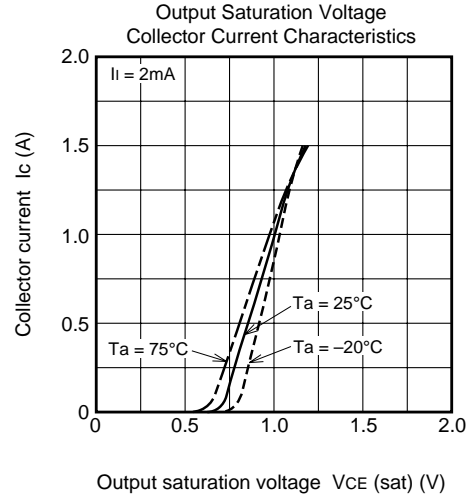
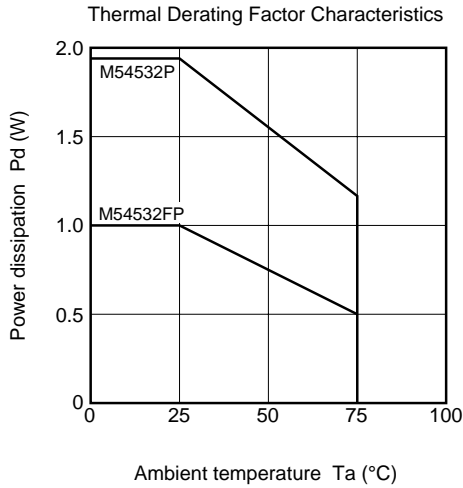

www.BDTIC.com/MITSUBISHI

4-UNIT 1.5A DARLINGTON TRANSISTOR ARRAY WITH CLAMP DIODE

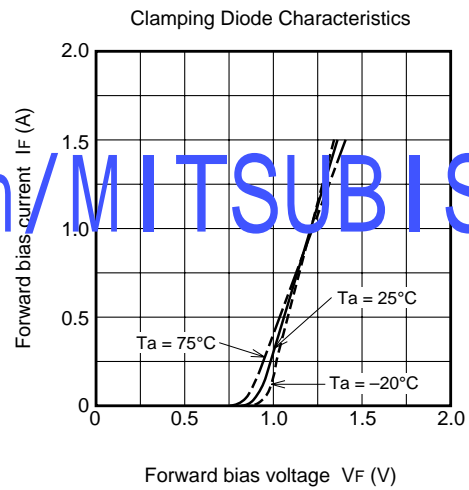
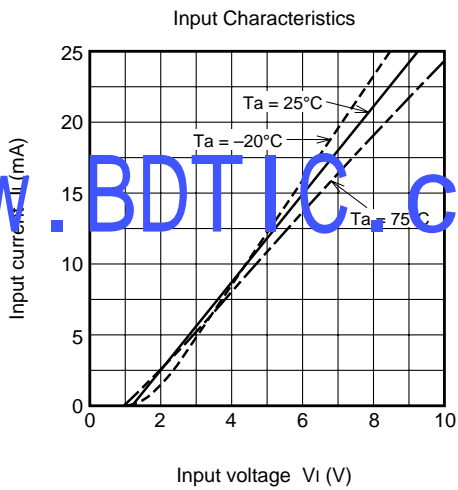
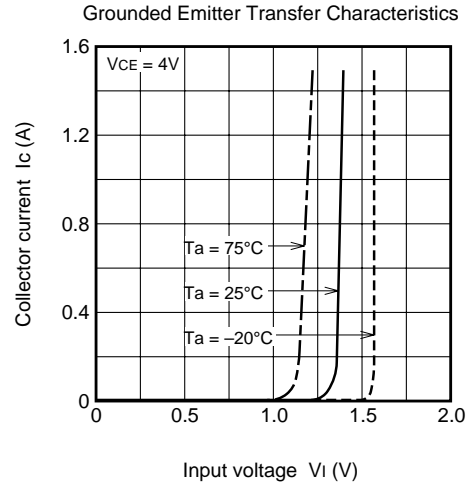
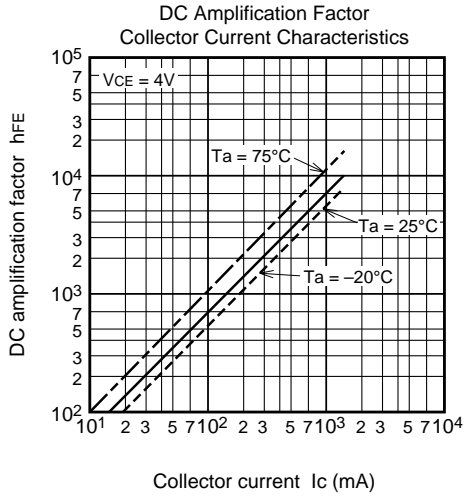

www.BDTIC.com/MITSUBISHI