

M54563P/FP

8-UNIT 500mA SOURCE TYPE DARLINGTON TRANSISTOR ARRAY WITH CLAMP DIODE

DESCRIPTION

M54563FP is an eight-circuit output-sourcing Darlington transistor array. The circuits are made of PNP and NPN transistors. This semiconductor integrated circuit performs high-current driving with extremely low input-current supply.

FEATURES

- High breakdown voltage ($BV_{CEO} \geq 50V$)
- High-current driving ($I_{o(max)} = -500mA$)
- With clamping diodes
- Driving available with PMOS IC output of 6 ~ 16V or with TTL output
- Wide operating temperature range ($T_a = -20$ to $+75^\circ C$)
- Output current-sourcing type

APPLICATION

Drives of relays, printers, LEDs, fluorescent display tubes and lamps, and interfaces between MOS-bipolar logic systems and relays, solenoids, or small motors

FUNCTION

The M54563P and M54563FP each have eight circuits, which are made of input inverters and current-sourcing outputs. The outputs are made of PNP transistors and NPN Darlington transistors. The PNP transistor base current is constant. A clamping diode is provided between each output and GND. V_s and GND are used commonly among the eight circuits.

The inputs have resistance of $3k\Omega$, and voltage of up to 10V is applicable. Output current is 500 mA maximum. Supply voltage V_s is 50V maximum.

The M54563FP is enclosed in a molded small flat package, enabling space-saving design.

PIN CONFIGURATION

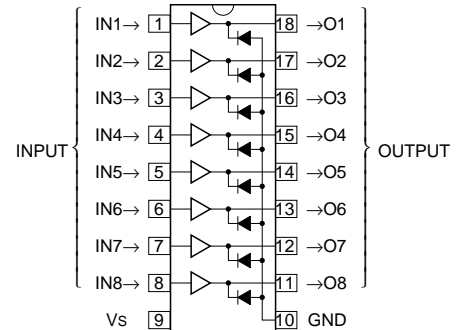

Package type 18P4G(P)

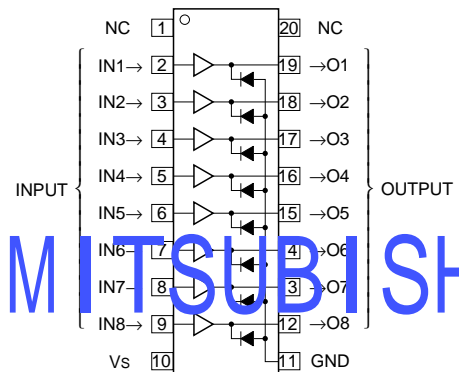

Package type 20P2N-A(FP)

NC : No connection

CIRCUIT DIAGRAM

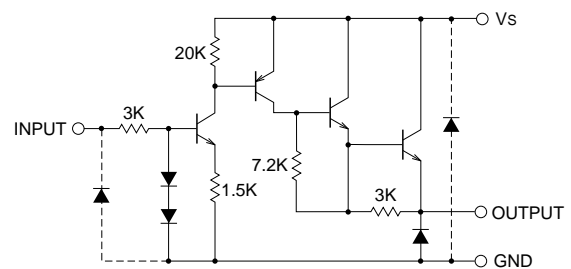

The eight circuits share the V_s and GND.

The diode, indicated with the dotted line, is parasitic, and cannot be used.

Unit : Ω

www.BDTIC.com/MITSUBISHI

M54563P/FP

8-UNIT 500mA SOURCE TYPE DARLINGTON TRANSISTOR ARRAY WITH CLAMP DIODE

ABSOLUTE MAXIMUM RATINGS (Unless otherwise noted, Ta = -20 ~ +75°C)

Symbol	Parameter	Conditions	Ratings	Unit
V _{CEO} #	Collector-emitter voltage	Output, L	-0.5 ~ +50	V
V _S	Supply voltage		50	V
V _I	Input voltage		-0.5 ~ +10	V
I _O	Output current	Current per circuit output, H	-500	mA
I _F	Clamping diode forward current		-500	mA
V _R #	Clamping diode reverse voltage		50	V
P _d	Power dissipation	Ta = 25°C, when mounted on board	1.79(P)/1.10(FP)	W
T _{opr}	Operating temperature		-20 ~ +75	°C
T _{stg}	Storage temperature		-55 ~ +125	°C

: Unused I/O pins must be connected to GND.

RECOMMENDED OPERATING CONDITIONS (Unless otherwise noted, Ta = -20 ~ +75°C)

Symbol	Parameter	Limits			Unit	
		min	typ	max		
V _S	Supply voltage	0	—	50	V	
I _O	Output current (Current per 1 circuit when 8 circuits are coming on simultaneously)	Duty Cycle P : no more than 8% FP : no more than 5%	0	—	-350	mA
		Duty Cycle P : no more than 55% FP : no more than 30%	0	—	-100	
V _{IH}	"H" input voltage	2.4	—	10	V	
V _{IL}	"L" input voltage	0	—	0.2	V	

ELECTRICAL CHARACTERISTICS (Unless otherwise noted, Ta = -20 ~ +75°C)

Symbol	Parameter	Test conditions	Limits			Unit
			min	typ*	max	
I _{S (leak)} #	Supply leak current	V _S = 50V, V _I = 0.2V	—	—	100	μA
V _{CE (sat)}	Collector-emitter saturation voltage	V _S = 10V, V _I = 2.4V, I _O = -350mA	—	1.6	2.4	V
		V _S = 10V, V _I = 2.4V, I _O = -100mA	—	1.45	2.0	
I _I	Input current	V _I = 3V	—	0.6	1.0	mA
		V _I = 10V	—	2.9	5.0	
I _S	Supply current	V _S = 50V, V _I = 3V (all input)	—	5.6	15.0	mA
V _F	Clamping diode forward voltage	I _F = -350mA	—	-1.2	-2.4	V
I _R #	Clamping diode reverse current	V _R = 50V	—	—	100	μA

* : The typical values are those measured under ambient temperature (Ta) of 25°C. There is no guarantee that these values are obtained under any conditions.

: Unused I/O pins must be connected to GND.

SWITCHING CHARACTERISTICS (Unless otherwise noted, Ta = 25°C)

Symbol	Parameter	Test conditions	Limits			Unit
			min	typ	max	
t _{on}	Turn-on time	C _L = 15pF (note 1)	—	100	—	ns
t _{off}	Turn-off time		—	4800	—	ns

M54563P/FP

8-UNIT 500mA SOURCE TYPE DARLINGTON TRANSISTOR ARRAY WITH CLAMP DIODE

NOTE 1 TEST CIRCUIT

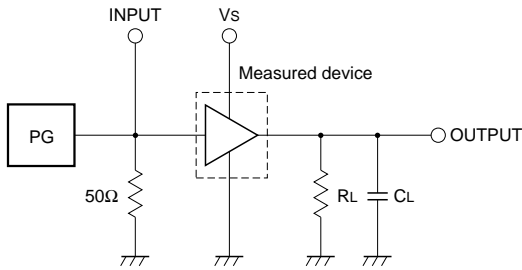

- (1) Pulse generator (PG) characteristics : PRR = 1kHz,
tw = 10μs, tr = 6ns, tf = 6ns, Zo = 50Ω
Vi = 0 to 2.4V
- (2) Input-output conditions : RL = 30Ω, Vs = 10V
- (3) Electrostatic capacity CL includes floating capacitance at connections and input capacitance at probes

TIMING DIAGRAM

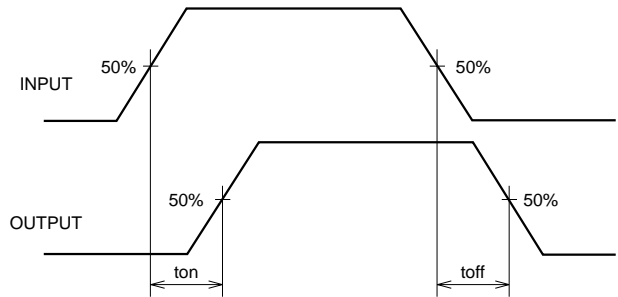

TYPICAL CHARACTERISTICS

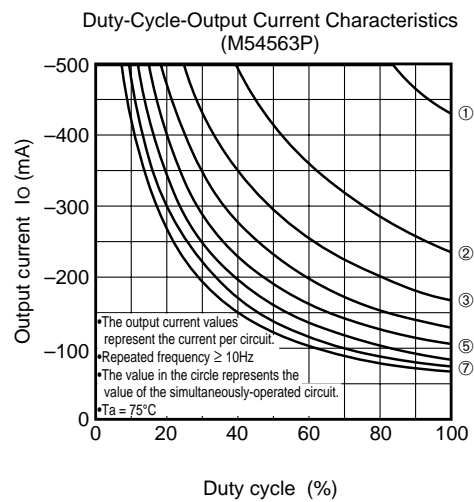
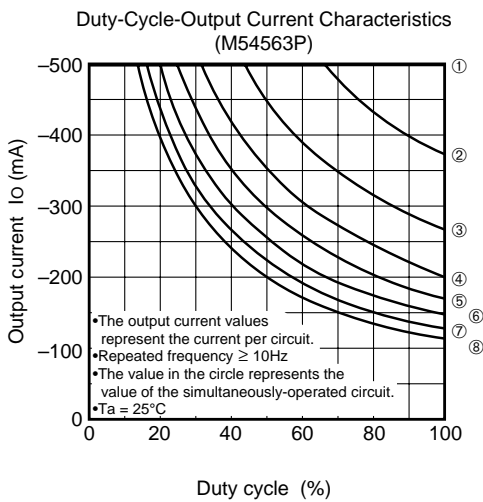
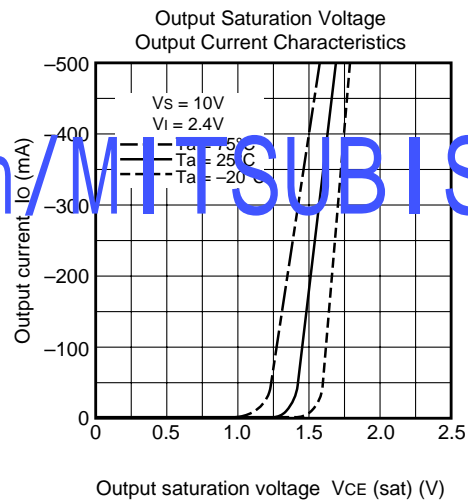
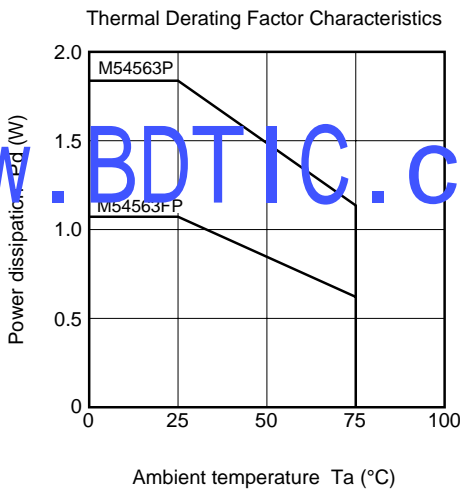

www.BDTIC.com/MITSUBISHI

M54563P/FP

8-UNIT 500mA SOURCE TYPE DARLINGTON TRANSISTOR ARRAY WITH CLAMP DIODE

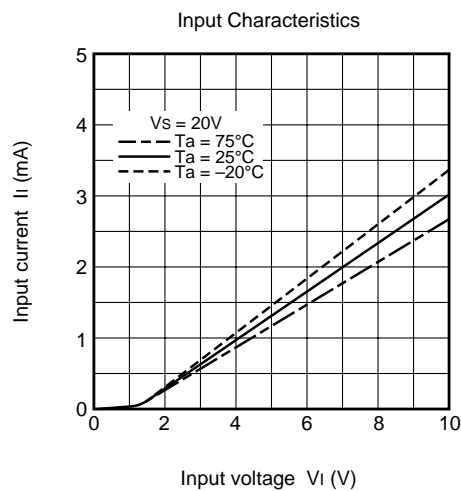
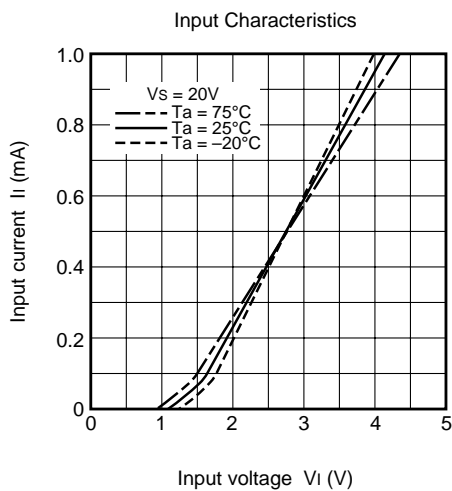
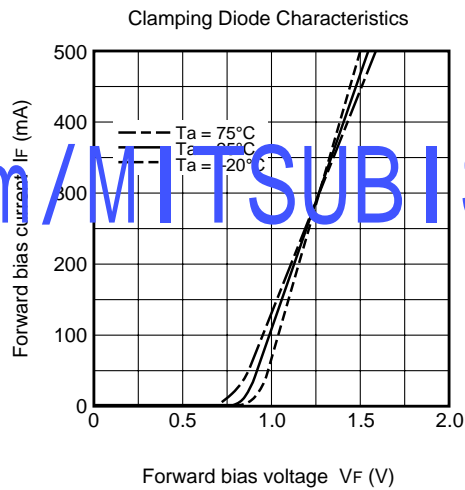
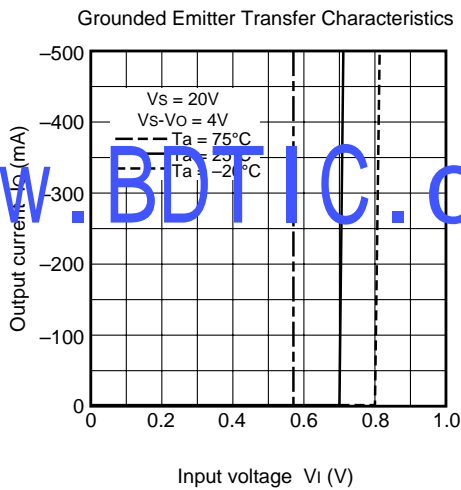
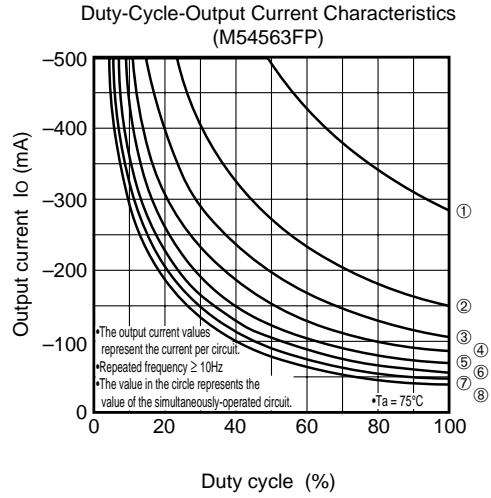
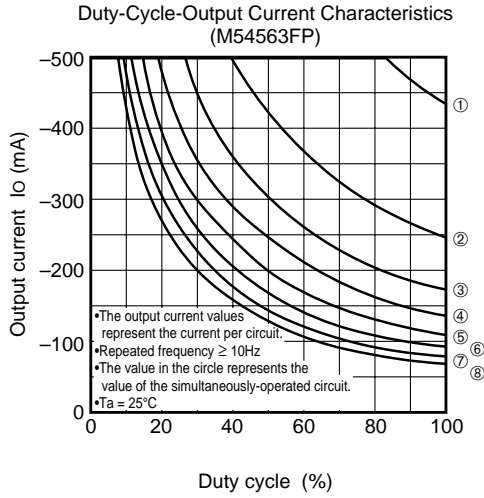

www.BDTIC.com/MITSUBISHI