

MITSUBISHI IGBT Module

# MG200Q2YS60A(1200V/200A 2in1)

High Power Switching Applications

Motor Control Applications

- Integrates a complete half bridge power circuit and fault-signal output circuit in one package.  
(short circuit and over temperature)
- The electrodes are isolated from case.
- Low thermal resistance
- $V_{CE(sat)} = 2.4 \text{ V (typ.)}$

## Equivalent Circuit

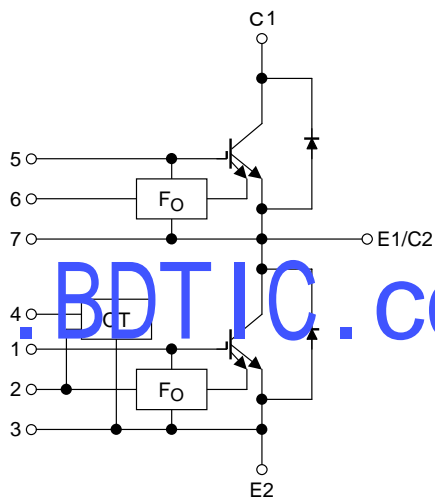

[www.BDTIC.com/MITSUBISHI](http://www.BDTIC.com/MITSUBISHI)

Signal terminal

1. G (L)	2. FO (L)	3. E (L)	4. VD
5. G (H)	6. FO (H)	7. E (H)	8. Open



## Maximum Ratings (Ta = 25°C)

Stage	Characteristics	Symbol	Rating	Unit	
Inverter	Collector-emitter voltage	$V_{CES}$	1200	V	
	Gate-emitter voltage	$V_{GES}$	$\pm 20$	V	
	Collector current	DC	$I_C$	200	A
		1 ms	$I_{CP}$	400	
	Forward current	DC	$I_F$	200	A
		1 ms	$I_{FM}$	400	
Collector power dissipation (Tc = 25°C)		$P_C$	2000	W	
Control	Control voltage (OT)	$V_D$	20	V	
	Fault input voltage	$V_{FO}$	20	V	
	Fault input current	$I_{FO}$	20	mA	
Module	Junction temperature	$T_j$	150	°C	
	Storage temperature range	$T_{stg}$	-40~125	°C	
	Operation temperature range	$T_{ope}$	-20~100	°C	
	Isolation voltage	$V_{isol}$	2500 (AC 1 min)	V	
	Screw torque	—	3 (M5)	N·m	

## Electrical Characteristics (Tj = 25°C)

## 1. Inverter Stage

Characteristics	Symbol	Test Condition	Min	Typ.	Max	Unit	
Gate leakage current	$I_{GES}$	$V_{CE} = \pm 20 \text{ V}, V_{GE} = 0$	—	—	$\pm 3/4$	mA	
		$V_{GE} = +10 \text{ V}, V_{CE} = 0$	—	—	100	nA	
Collector cut-off current	$I_{CES}$	$V_{CE} = 1200 \text{ V}, V_{GE} = 0$	—	—	1.0	mA	
Gate-emitter cut-off voltage	$V_{GE} \text{ (off)}$	$V_{CE} = 5 \text{ V}, I_C = 200 \text{ mA}$	6.0	7.0	8.0	V	
Collector-emitter saturation voltage	$V_{CE} \text{ (sat)}$	$V_{GE} = 15 \text{ V}, I_C = 200 \text{ A}$	$T_j = 25^\circ\text{C}$	—	2.4	2.8	V
			$T_j = 125^\circ\text{C}$	—	—	3.2	
Input capacitance	$C_{ies}$	$V_{CE} = 10 \text{ V}, V_{GE} = 0, f = 1 \text{ MHz}$	—	15000	—	pF	
Switching time	Turn-on delay time	$V_{CC} = 600 \text{ V}, I_C = 200 \text{ A}$ $V_{GE} = \pm 15 \text{ V}, R_G = 10 \Omega$ (Note 1)	0.10	—	1.00	$\mu\text{s}$	
	Turn-off time		—	—	2.00		
	Fall time		—	—	0.50		
Reverse recovery time	$t_{rr}$		—	—	0.50		
Forward voltage	$V_F$	$I_F = 200 \text{ A}$	—	2.4	2.8	V	

Note 1: Switching time test circuit &amp; timing chart

## 2. Control (Tc = 25°C)

Characteristics	Symbol	Test Condition	Min	Typ.	Max	Unit
Fault output current	OC	$V_{GE} = 15 \text{ V}$	240	—	—	A
Over temperature	OT	—	100	—	125	°C
Fault output delay time	$t_d \text{ (Fo)}$	$V_{CC} = 600 \text{ V}, V_{GE} = \pm 15 \text{ V}$	—	—	8	$\mu\text{s}$

3. Module (Tc = 25°C)

Characteristics	Symbol	Test Condition	Min	Typ.	Max	Unit
Junction to case thermal resistance	$R_{th(j-c)}$	Inverter IGBT stage	—	—	0.062	°C/W
		Inverter FRD stage	—	—	0.136	
Case to fin thermal resistance	$R_{th(c-f)}$	With silicon compound	—	0.013	—	°C/W

Switching Time Test Circuit

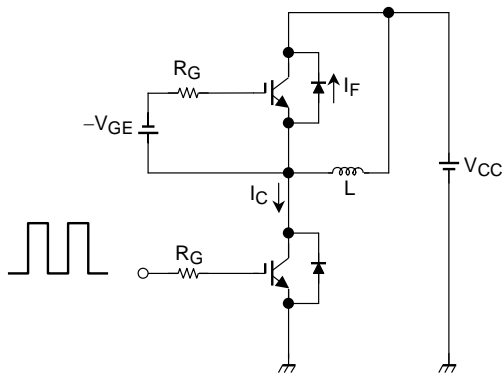

Timing Chart

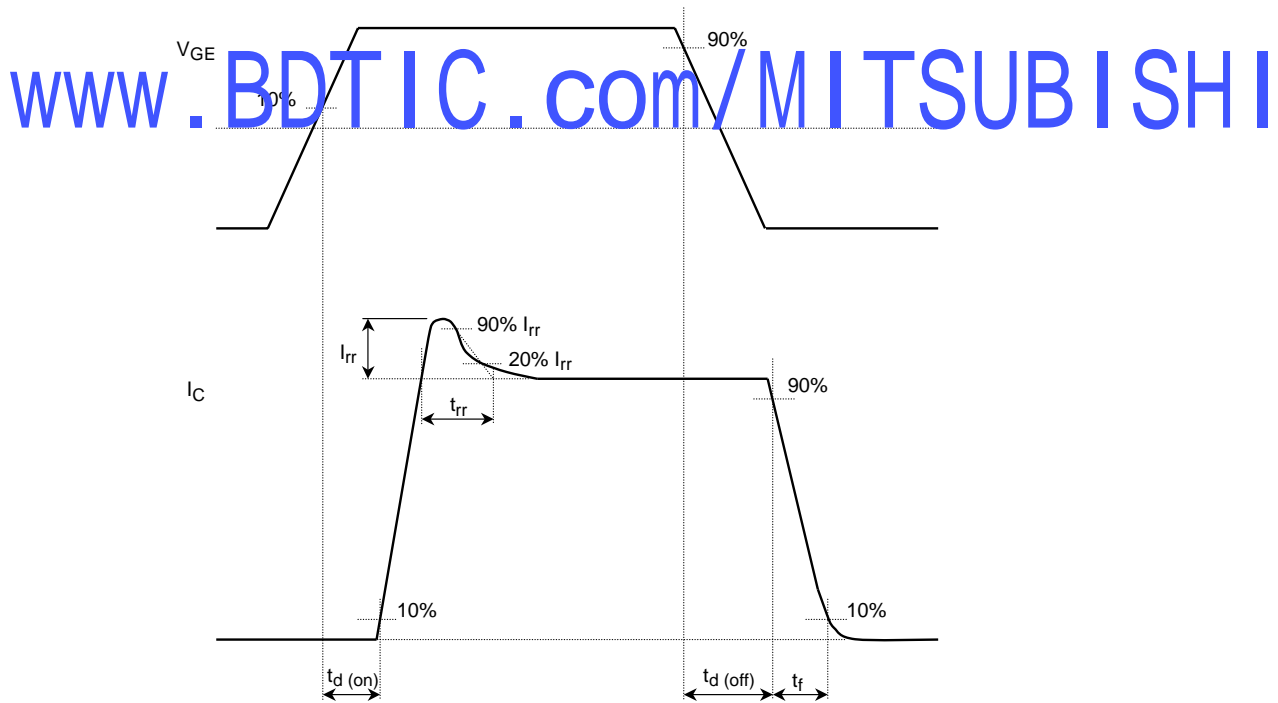

**Remark****<Short circuit capability condition>**

- Short circuit capability is 6  $\mu$ s after fault output signal.  
Please keep following condition to use fault output signal.
  - $V_{CC} \leq 750$  V
  - $14.8$  V  $\leq V_{GE} \leq 17.0$  V
  - $R_G \geq 10$   $\Omega$
  - $T_j \leq 125^\circ$ C

**<Gate voltage>**

- To use this product,  $V_{GE}$  must be provided higher than 14.8 V.  
In case  $V_{GE}$  is less than 14.8 V, fault signal FO may not be output even under error conditions.

**<Recommended conditions for application>**

Characteristics	Symbol	Min	Typ.	Max	Unit
P-N power terminal supply voltage	$V_{CC}$	—	600	750	V
Gate voltage	$V_{GE}$	14.8	15	17	V
Gate resistance	$R_G$	10	—	—	$\Omega$
Switching frequency	fc	—	—	20	kHz

[www.BDTIC.com/MITSUBISHI](http://www.BDTIC.com/MITSUBISHI)

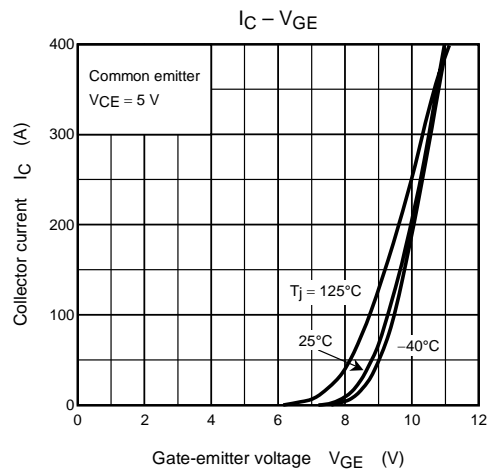
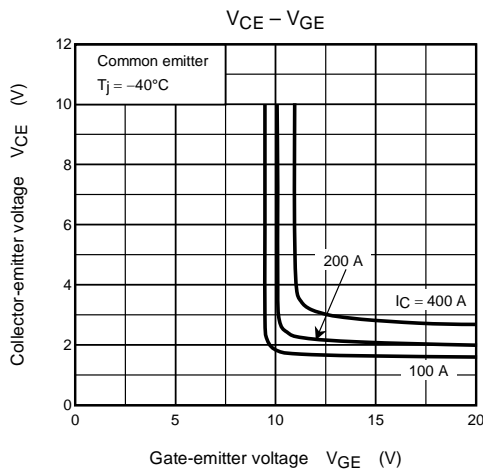
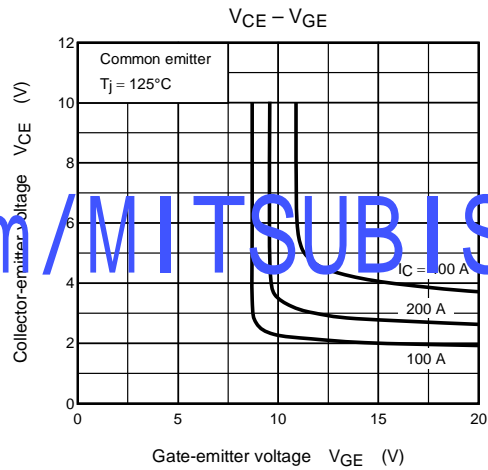
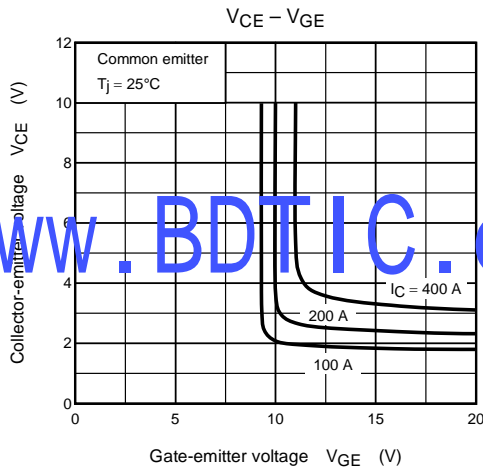
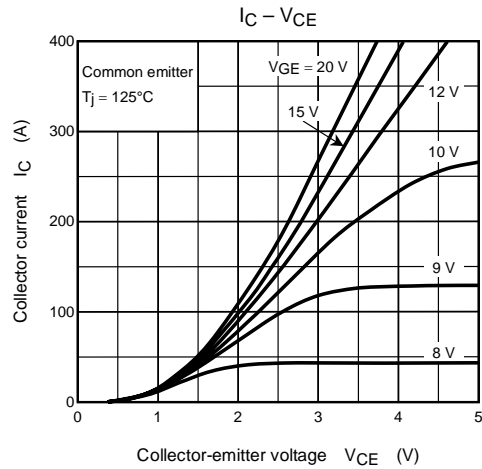
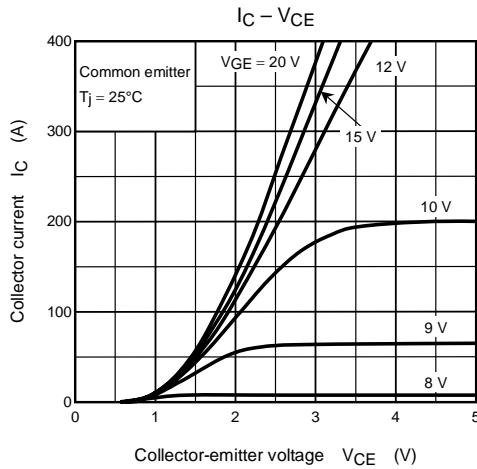

www.BDTIC.com / MITSUBISHI

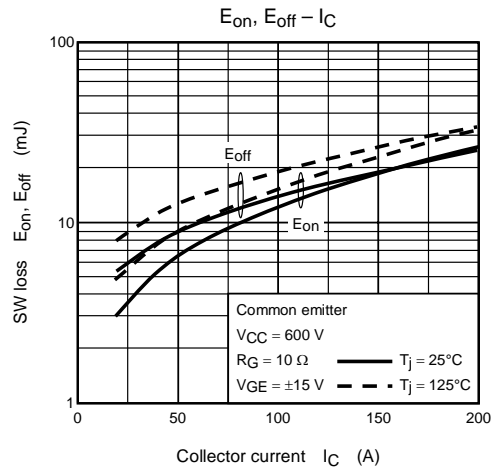
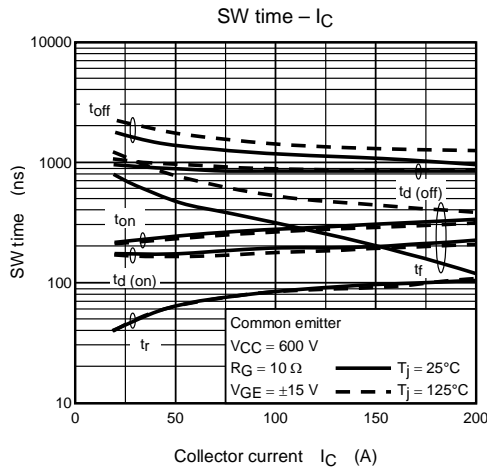
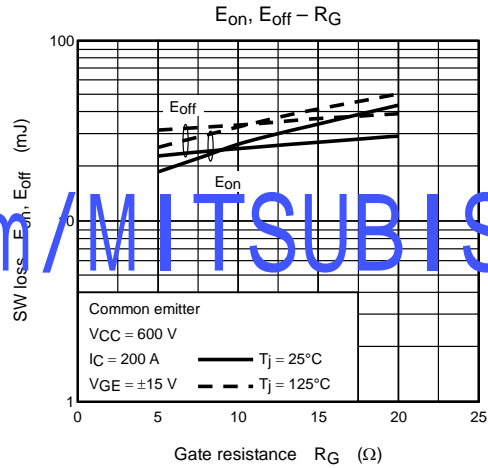
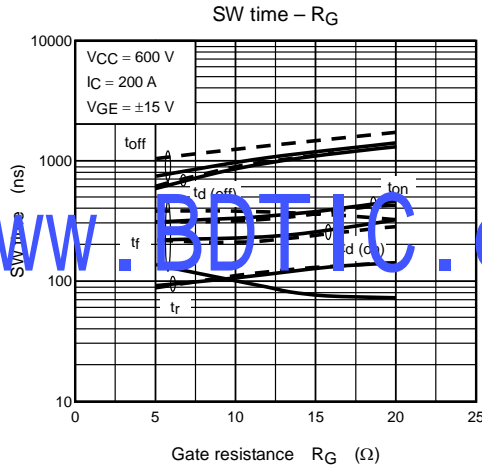
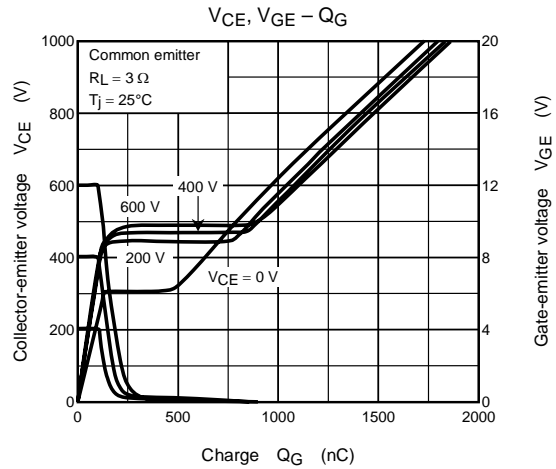
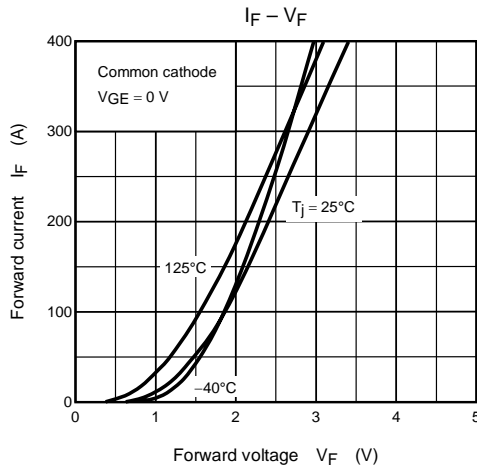

www.BDTIC.com / MITSUBISHI

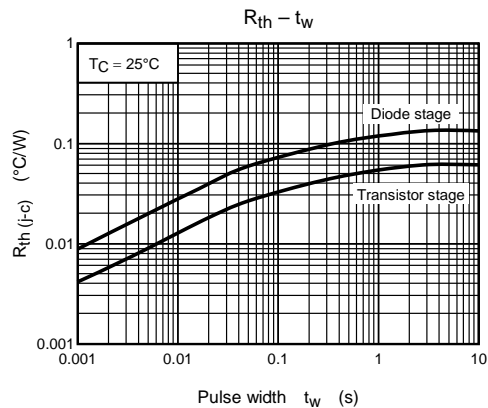
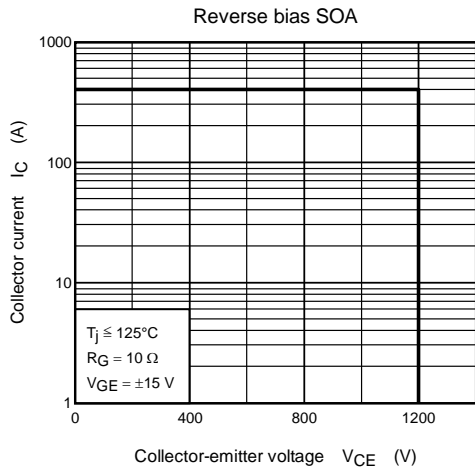
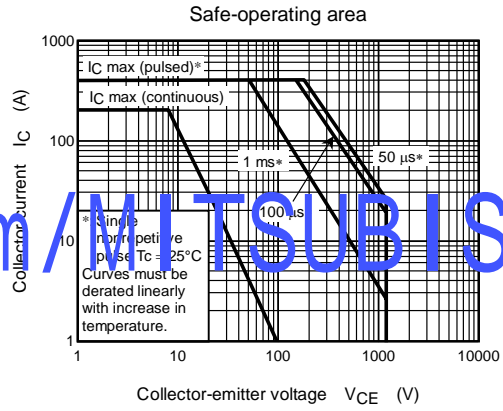
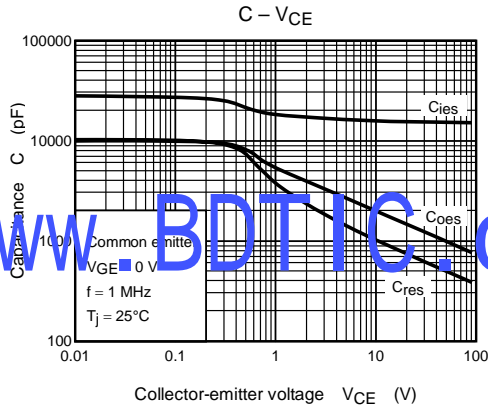
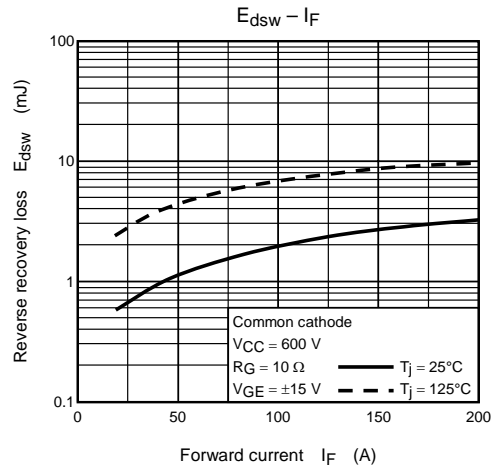
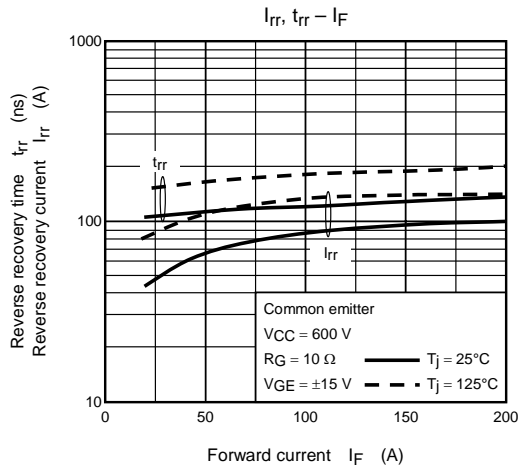

www.BDTIC.com / MITSUBISHI