

MITSUBISHI IGBT Module

MG300Q2YS60A(1200V/300A 2in1)

High Power Switching Applications

Motor Control Applications

- Integrates a complete half bridge power circuit and fault-signal output circuit in one package.
(short circuit and over temperature)
- The electrodes are isolated from case.
- Low thermal resistance
- $V_{CE(sat)} = 2.4 \text{ V (typ.)}$

Equivalent Circuit

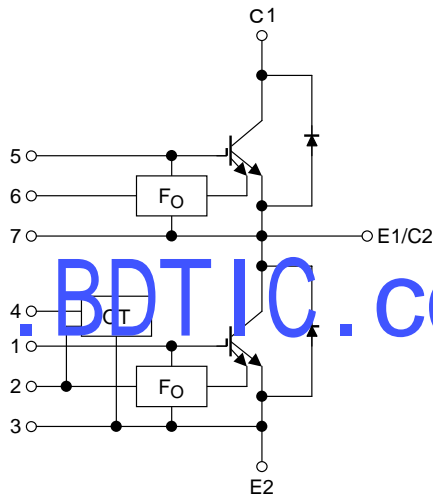

www.BDTIC.com/MITSUBISHI

Signal terminal

1.	G (L)	2.	FO (L)	3.	E (L)	4.	V _D
5.	G (H)	6.	FO (H)	7.	E (H)	8.	Open

Package Dimensions

Unit: mm

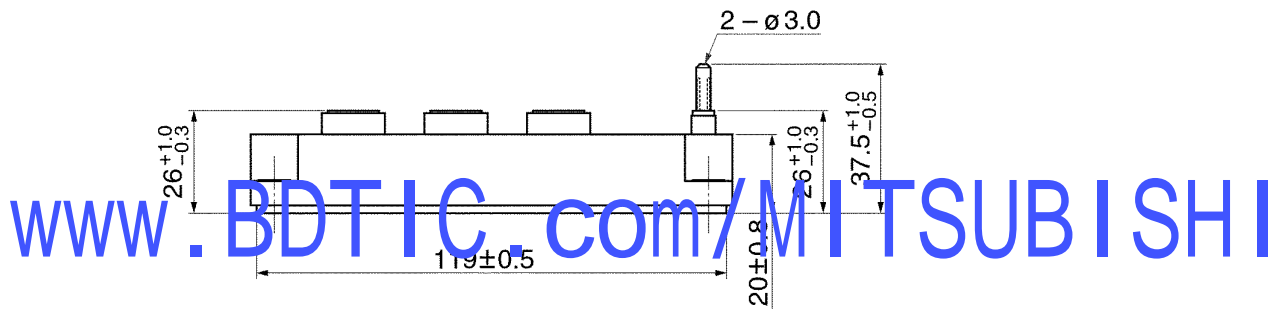
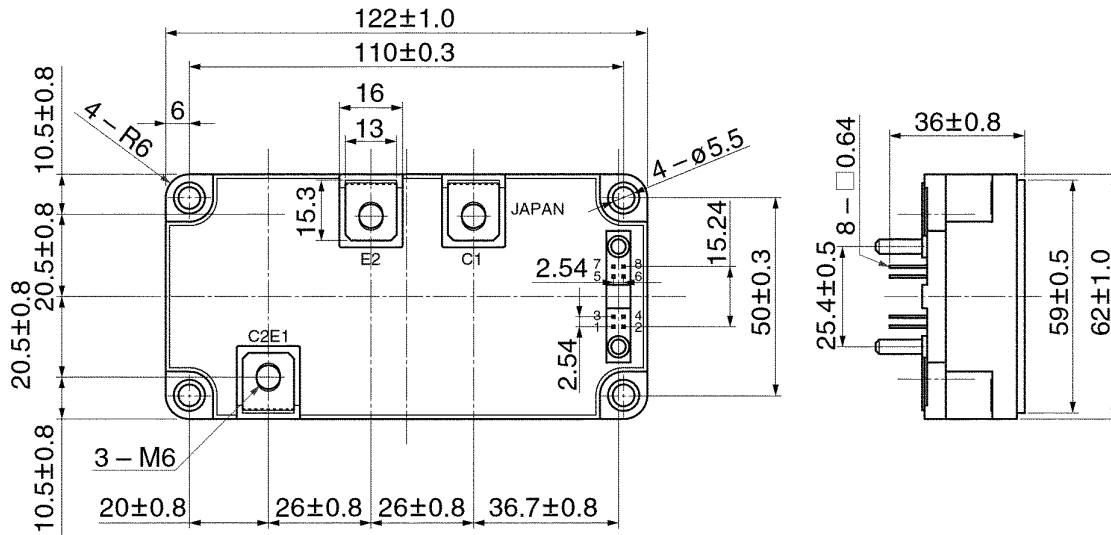

- | | | | | | | | |
|----|-------|----|--------------------|----|-------|----|----------------|
| 1. | G (L) | 2. | F _O (L) | 3. | E (L) | 4. | V _D |
| 5. | G (H) | 6. | F _O (H) | 7. | E (H) | 8. | Open |

Signal Terminal Layout

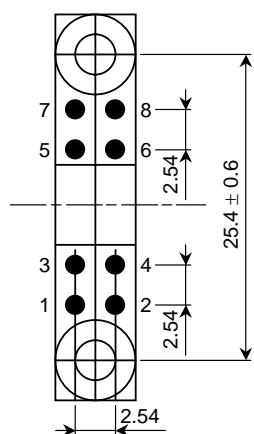

- | | | | | | | | |
|----|-------|----|--------------------|----|-------|----|----------------|
| 1. | G (L) | 2. | F _O (L) | 3. | E (L) | 4. | V _D |
| 5. | G (H) | 6. | F _O (H) | 7. | E (H) | 8. | Open |

Weight: 375 g

Maximum Ratings (Ta = 25°C)

Stage	Characteristics	Symbol	Rating	Unit	
Inverter	Collector-emitter voltage	V _{CES}	1200	V	
	Gate-emitter voltage	V _{GES}	±20	V	
	Collector current	DC	I _C	300	A
		1 ms	I _{CP}	600	
	Forward current	DC	I _F	300	A
		1 ms	I _{FM}	600	
Collector power dissipation (T _c = 25°C)		P _C	2800	W	
Control	Control voltage (OT)	V _D	20	V	
	Fault input voltage	V _{FO}	20	V	
	Fault input current	I _{FO}	20	mA	
Module	Junction temperature	T _j	150	°C	
	Storage temperature range	T _{stg}	-40~125	°C	
	Operation temperature range	T _{ope}	-20~100	°C	
	Isolation voltage	V _{isol}	2500 (AC 1 min)	V	
	Screw torque	—	3 (M5)	N·m	

Electrical Characteristics (T_j = 25°C)

1. Inverter Stage

Characteristics	Symbol	Test Condition	Min	Typ.	Max	Unit	
Gate leakage current	I _{GES}	V _{CE} = ±20 V, V _{GE} = 0	—	—	±3/4	mA	
		V _{GE} = +10 V, V _{CE} = 0	—	—	100	nA	
Collector cut-off current	I _{CES}	V _{CE} = 1200 V, V _{GE} = 0	—	—	1.0	mA	
Gate-emitter cut-off voltage	V _{GE (off)}	V _{CE} = 5 V, I _C = 300 mA	6.0	7.0	8.0	V	
Collector-emitter saturation voltage	V _{CE (sat)}	V _{GE} = 15 V, I _C = 300 A	T _j = 25°C	—	2.4	2.8	V
			T _j = 125°C	—	—	3.2	
Input capacitance	C _{ies}	V _{CE} = 10 V, V _{GE} = 0, f = 1 MHz	—	21000	—	pF	
Switching time	Turn-on delay time	t _{d (on)}	V _{CC} = 600 V, I _C = 300 A V _{GE} = ±15 V, R _G = 6.8 Ω (Note 1)	0.10	—	1.00	μs
	Turn-off time	t _{off}		—	—	2.00	
	Fall time	t _f		—	—	0.50	
Reverse recovery time	t _{rr}		—	—	0.50		
Forward voltage	V _F	I _F = 300 A	—	2.1	2.6	V	

Note 1: Switching time test circuit & timing chart

2. Control (T_c = 25°C)

Characteristics	Symbol	Test Condition	Min	Typ.	Max	Unit
Fault output current	OC	V _{GE} = 15 V	360	—	—	A
Over temperature	OT	—	100	—	125	°C
Fault output delay time	t _{d (Fo)}	V _{CC} = 600 V, V _{GE} = ±15 V	—	—	8	μs

3. Module (Tc = 25°C)

Characteristics	Symbol	Test Condition	Min	Typ.	Max	Unit
Junction to case thermal resistance	R _{th (j-c)}	Inverter IGBT stage	—	—	0.044	°C/W
		Inverter FRD stage	—	—	0.068	
Case to fin thermal resistance	R _{th (c-f)}	With silicon compound	—	0.013	—	°C/W

Switching Time Test Circuit

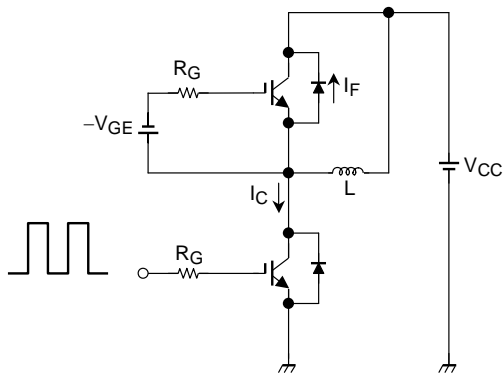

Timing Chart

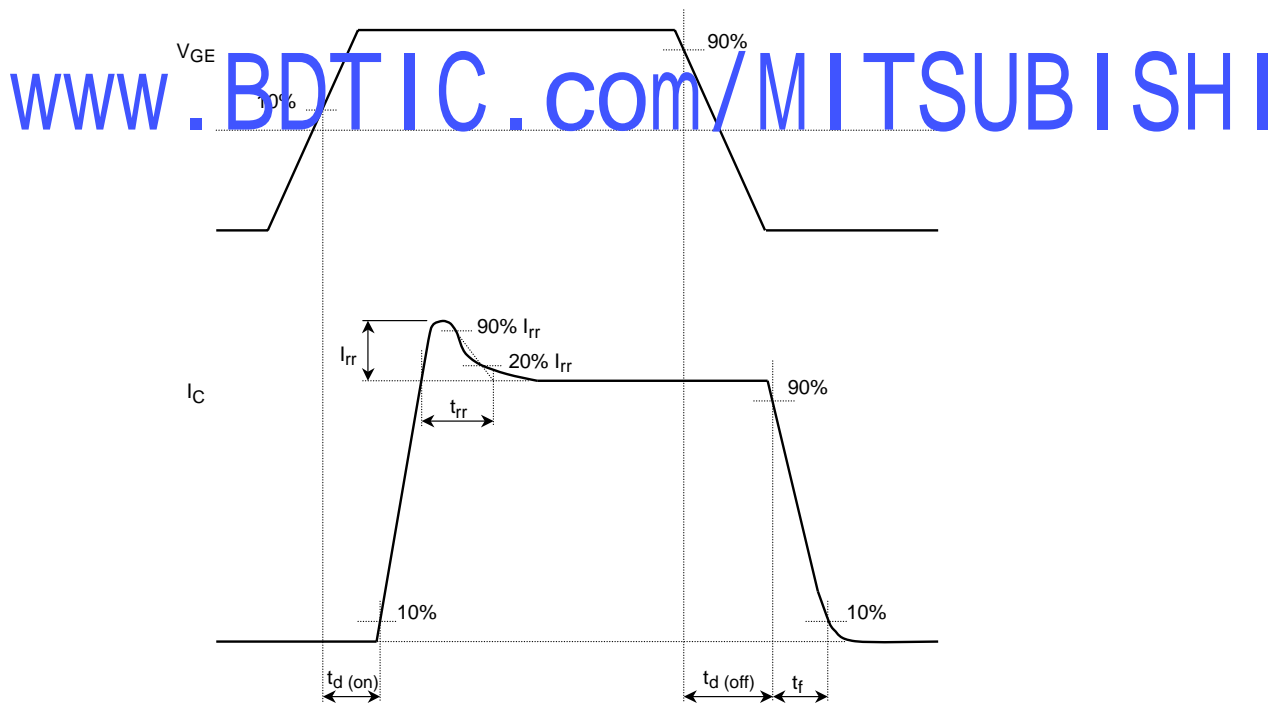

Remark**<Short circuit capability condition>**

- Short circuit capability is 6 μ s after fault output signal.
Please keep following condition to use fault output signal.
 - $V_{CC} \leq 750$ V
 - 14.8 V $\leq V_{GE} \leq 17.0$ V
 - $R_G \geq 6.8$ Ω
 - $T_j \leq 125^\circ$ C

<Gate voltage>

- To use this product, V_{GE} must be provided higher than 14.8 V.
In case V_{GE} is less than 14.8 V, fault signal FO may not be output even under error conditions.

<Recommended conditions for application>

Characteristics	Symbol	Min	Typ.	Max	Unit
P-N power terminal supply voltage	V_{CC}	—	600	750	V
Gate voltage	V_{GE}	14.8	15	17	V
Gate resistance	R_G	6.8	—	—	Ω
Switching frequency	fc	—	—	20	kHz

www.BDTIC.com/MITSUBISHI

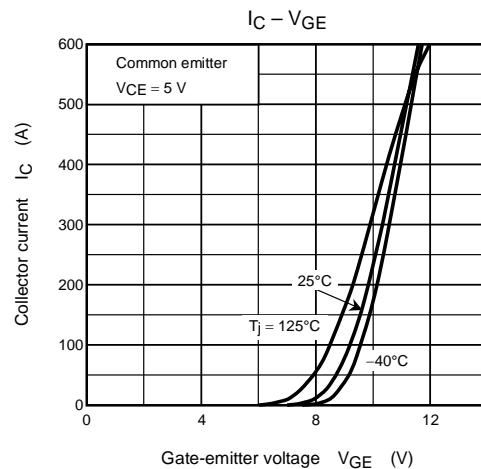
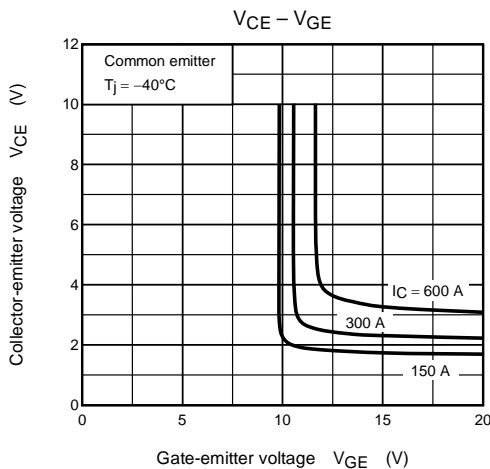
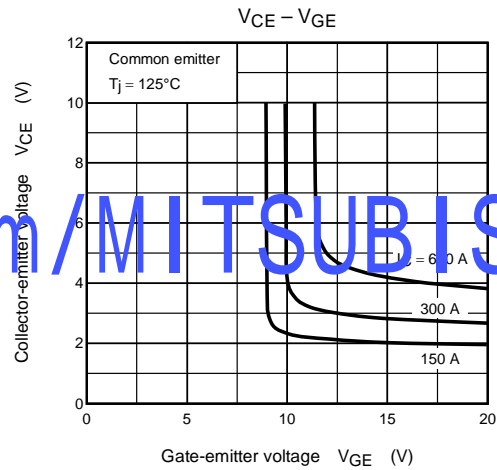
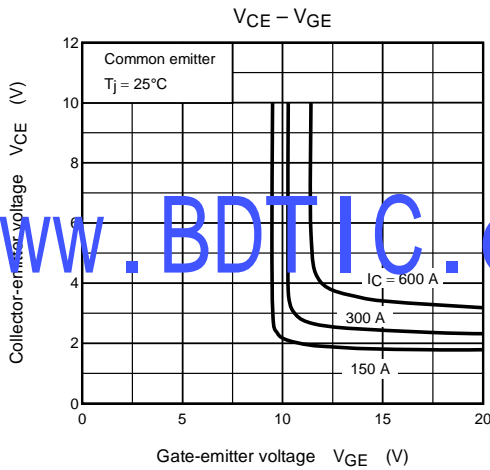
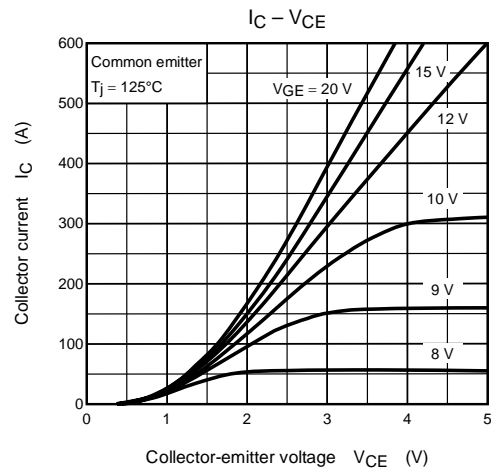
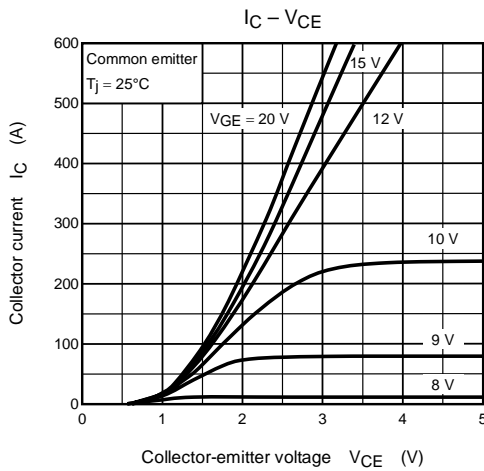

www.BDTIC.com / MITSUBISHI

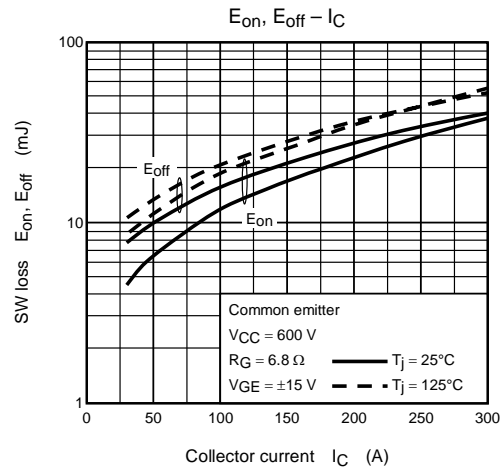
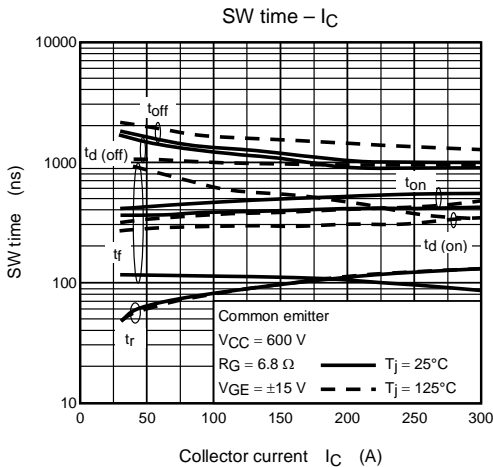
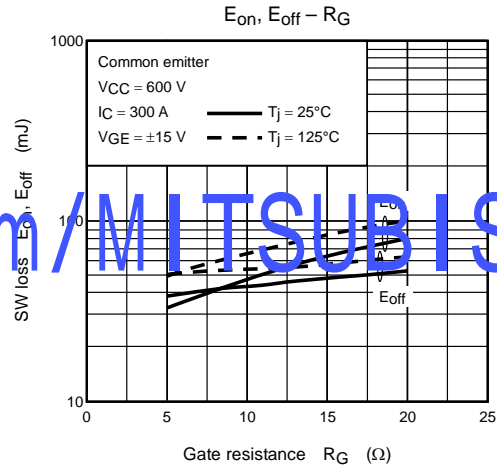
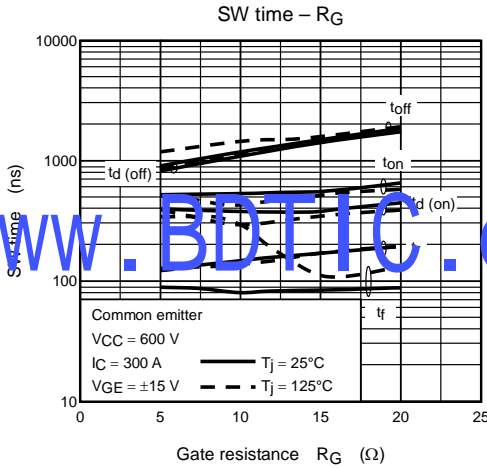
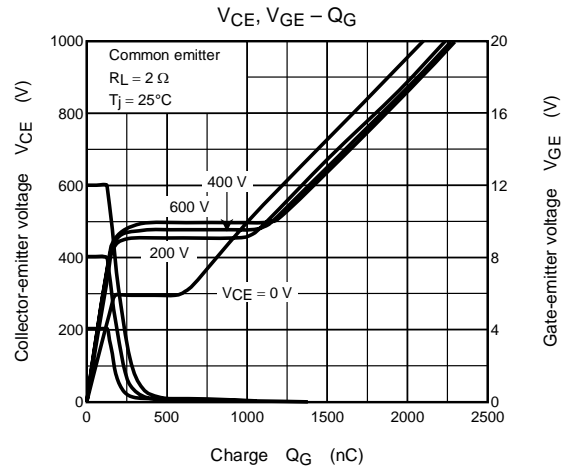
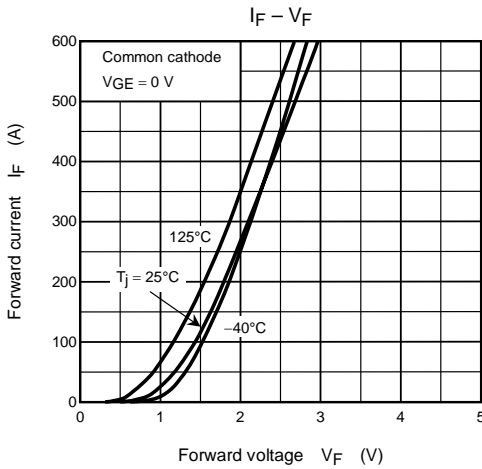

www.BDTIC.com / MITSUBISHI

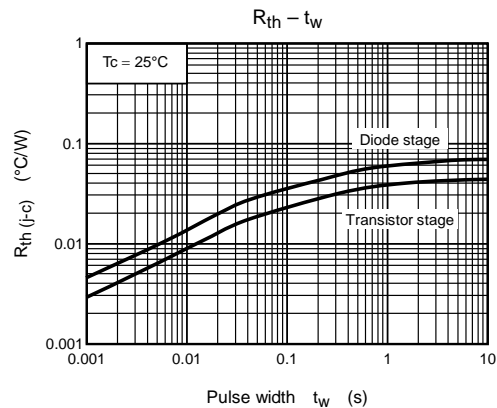
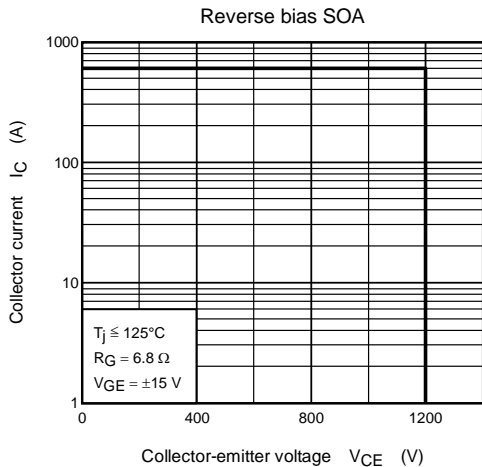
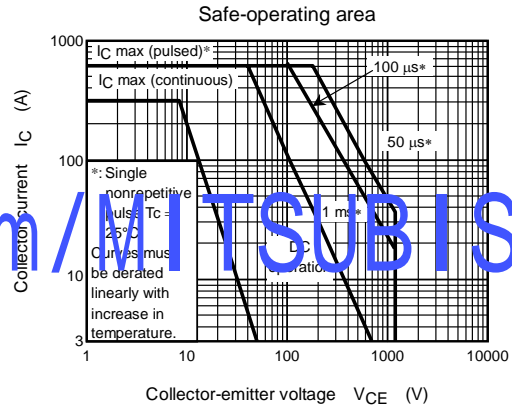
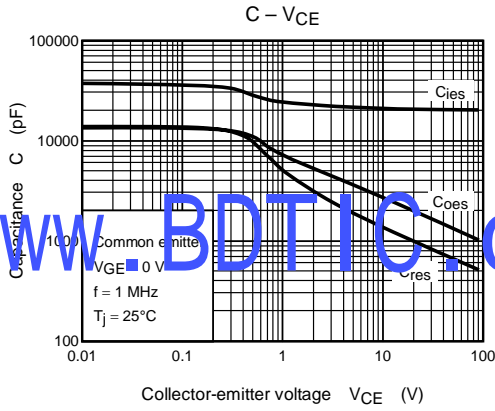
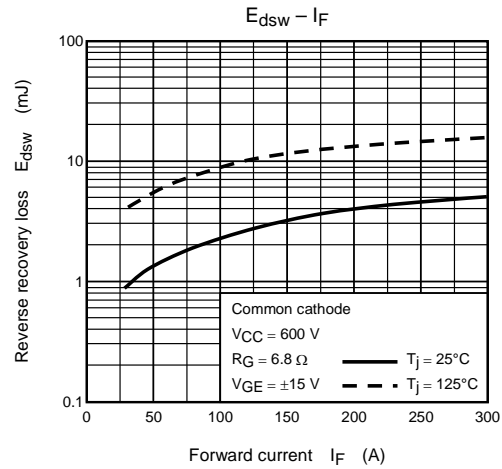
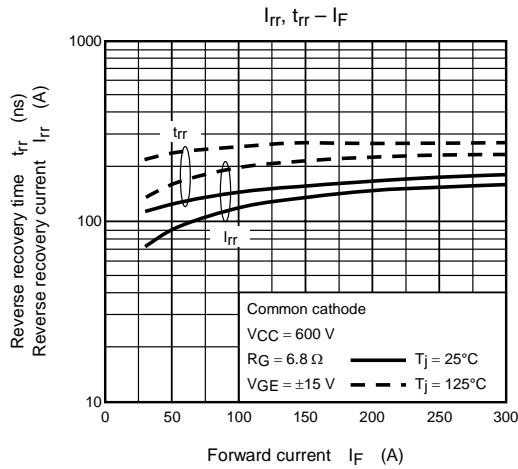

www.BDTIC.com / MITSUBISHI