

MITSUBISHI IGBT Module

# MG600J2YS61A(600V/600A 2in1)

High Power Switching Applications

Motor Control Applications

- Integrates a complete half bridge power circuit and fault-signal output circuit in one package.  
(short circuit and over temperature)
- The electrodes are isolated from case.
- Low thermal resistance
- $V_{CE(sat)} = 2.2 \text{ V (typ.)}$

## Equivalent Circuit

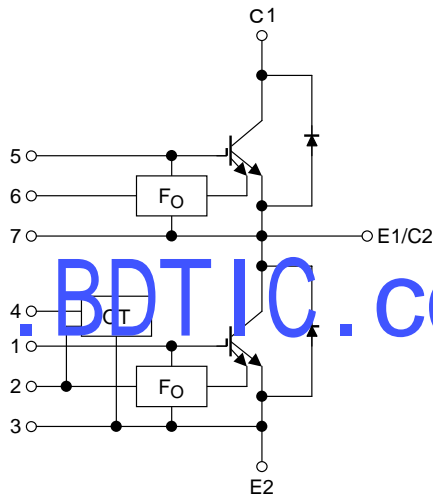

[www.BDTIC.com/MITSUBISHI](http://www.BDTIC.com/MITSUBISHI)

Signal terminal

1.	G (L)	2.	FO (L)	3.	E (L)	4.	V <sub>D</sub>
5.	G (H)	6.	FO (H)	7.	E (H)	8.	Open

Package Dimensions

Unit: mm

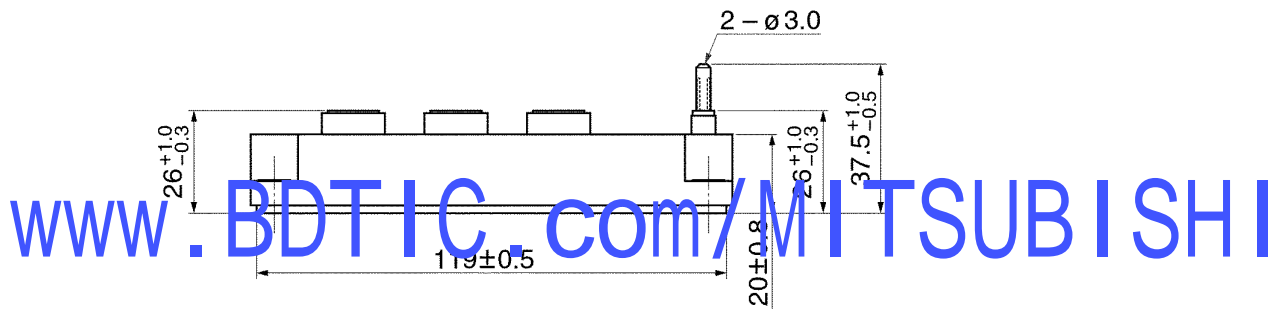
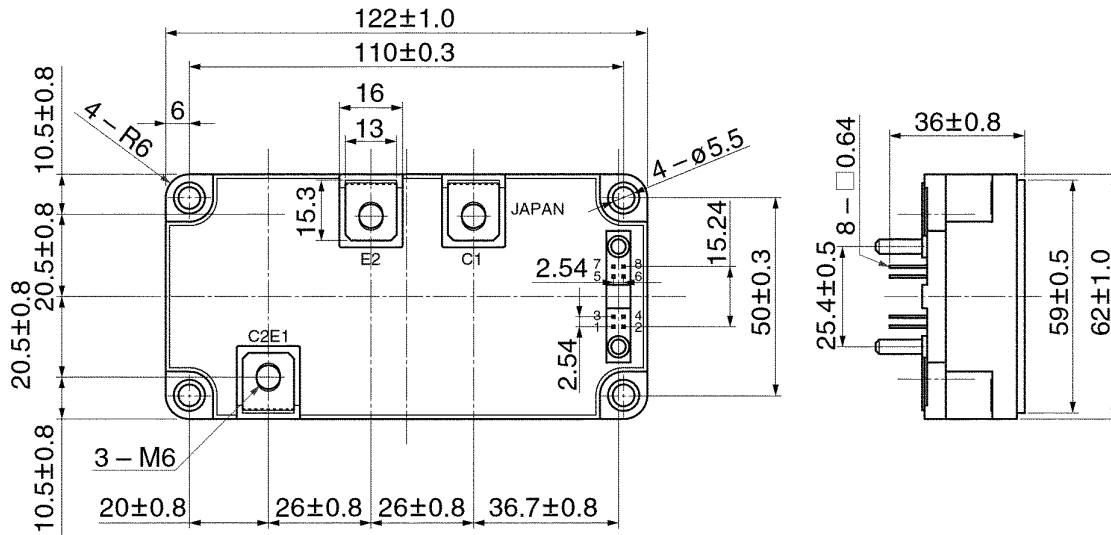

- |    |       |    |                    |    |       |    |                |
|----|-------|----|--------------------|----|-------|----|----------------|
| 1. | G (L) | 2. | F <sub>O</sub> (L) | 3. | E (L) | 4. | V <sub>D</sub> |
| 5. | G (H) | 6. | F <sub>O</sub> (H) | 7. | E (H) | 8. | Open           |

Signal Terminal Layout

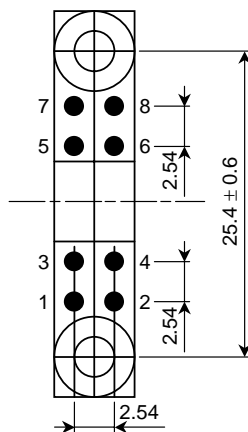

- |    |       |    |                    |    |       |    |                |
|----|-------|----|--------------------|----|-------|----|----------------|
| 1. | G (L) | 2. | F <sub>O</sub> (L) | 3. | E (L) | 4. | V <sub>D</sub> |
| 5. | G (H) | 6. | F <sub>O</sub> (H) | 7. | E (H) | 8. | Open           |

Weight: 375 g

**Maximum Ratings (Ta = 25°C)**

Stage	Characteristics	Symbol	Rating	Unit	
Inverter	Collector-emitter voltage	$V_{CES}$	600	V	
	Gate-emitter voltage	$V_{GES}$	$\pm 20$	V	
	Collector current	DC	$I_C$	600	A
		1 ms	$I_{CP}$	1200	
	Forward current	DC	$I_F$	600	A
		1 ms	$I_{FM}$	1200	
Collector power dissipation (Tc = 25°C)		$P_C$	2770	W	
Control	Control voltage (OT)	$V_D$	20	V	
	Fault input voltage	$V_{FO}$	20	V	
	Fault input current	$I_{FO}$	20	mA	
Module	Junction temperature	$T_j$	150	°C	
	Storage temperature range	$T_{stg}$	-40~125	°C	
	Operation temperature range	$T_{ope}$	-20~100	°C	
	Isolation voltage	$V_{isol}$	2500 (AC 1 min)	V	
	Screw torque	—	3 (M5)	N·m	

**Electrical Characteristics (Tj = 25°C)****1. Inverter Stage**

Characteristics		Symbol	Test Condition	Min	Typ.	Max	Unit	
Gate leakage current		$I_{GES}$	$V_{CE} = \pm 20 \text{ V}, V_{GE} = 0$	—	—	$\pm 3/4$	mA	
			$V_{GE} = +10 \text{ V}, V_{CE} = 0$	—	—	100	nA	
Collector cut-off current		$I_{CES}$	$V_{CE} = 600 \text{ V}, V_{GE} = 0$	—	—	1.0	mA	
Gate-emitter cut-off voltage		$V_{GE} \text{ (off)}$	$V_{CE} = 5 \text{ V}, I_C = 600 \text{ mA}$	6.0	7.0	8.0	V	
Collector-emitter saturation voltage		$V_{CE} \text{ (sat)}$	$V_{GE} = 15 \text{ V}, I_C = 600 \text{ A}$	$T_j = 25^\circ\text{C}$	—	2.2	2.5	V
				$T_j = 125^\circ\text{C}$	—	—	2.8	
Input capacitance		$C_{ies}$	$V_{CE} = 10 \text{ V}, V_{GE} = 0, f = 1 \text{ MHz}$	—	125	—	nF	
Switching time	Turn-on delay time	$t_d \text{ (on)}$	$V_{CC} = 300 \text{ V}, I_C = 600 \text{ A}$ $V_{GE} = \pm 15 \text{ V}, R_G = 5.1 \Omega$ (Note 1)	0.10	—	1.00	$\mu\text{s}$	
	Turn-off time	$t_{off}$		—	—	2.00		
	Fall time	$t_f$		—	—	0.50		
Reverse recovery time	$t_{rr}$	—		—	0.50			
Forward voltage		$V_F$	$I_F = 600 \text{ A}$	—	2.2	2.6	V	

Note 1: Switching time test circuit &amp; timing chart

**2. Control (Tc = 25°C)**

Characteristics	Symbol	Test Condition	Min	Typ.	Max	Unit
Fault output current	OC	$V_{GE} = 15 \text{ V}$	720	—	—	A
Over temperature	OT	—	100	—	125	°C
Fault output delay time	$t_d \text{ (Fo)}$	$V_{CC} = 300 \text{ V}, V_{GE} = \pm 15 \text{ V}$	—	—	6.5	$\mu\text{s}$

3. Module (Tc = 25°C)

Characteristics	Symbol	Test Condition	Min	Typ.	Max	Unit
Junction to case thermal resistance	R <sub>th (j-c)</sub>	Inverter IGBT stage	—	—	0.045	°C/W
		Inverter FRD stage	—	—	0.068	
Case to fin thermal resistance	R <sub>th (c-f)</sub>	With silicon compound	—	0.013	—	°C/W

Switching Time Test Circuit

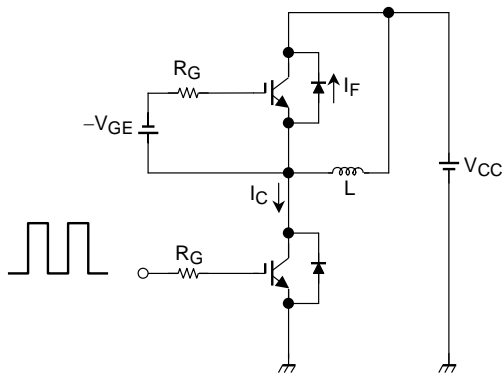

Timing Chart

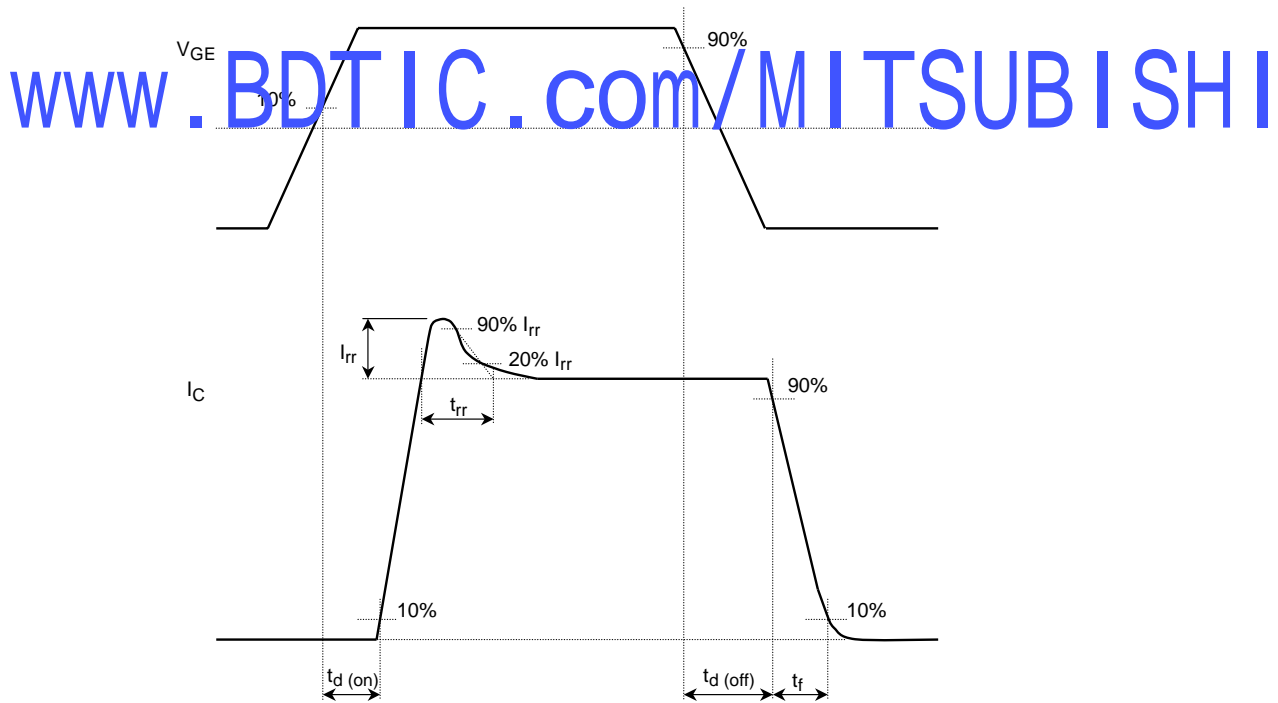

www.BDTIC.com/MITSUBISHI

**Remark****<Short circuit capability condition>**

- Short circuit capability is 6  $\mu$ s after fault output signal.  
Please keep following condition to use fault output signal.
  - $V_{CC} \leq 375$  V
  - $13.8$  V  $\leq V_{GE} \leq 16.0$  V
  - $R_G \geq 5.1$   $\Omega$
  - $T_j \leq 125^\circ$ C

**<Gate voltage>**

- To use this product,  $V_{GE}$  must be provided higher than 13.8 V.  
In case  $V_{GE}$  is less than 13.8 V, fault signal FO may not be output even under error conditions.

**<Recommended conditions for application>**

Characteristics	Symbol	Min	Typ.	Max	Unit
P-N power terminal supply voltage	$V_{CC}$	—	300	375	V
Gate voltage	$V_{GE}$	13.8	15	16	V
Gate resistance	$R_G$	5.1	—	—	$\Omega$
Switching frequency	fc	—	—	20	kHz

**<For parallel use>**

- For parallel use of this product, please use the same rank for both  $V_{CE(sat)}$  and  $V_F$  among IGBT in parallel without fail.

[www.BDTIC.com/MITSUBISHI](http://www.BDTIC.com/MITSUBISHI)

$V_{CE(sat)}$	Min	Max
20	1.8	2.0
22	1.9	2.2
24	2.1	2.4
26	2.3	2.5

$V_F$	Min	Max
D	1.9	2.2
E	2.1	2.4
F	2.3	2.6

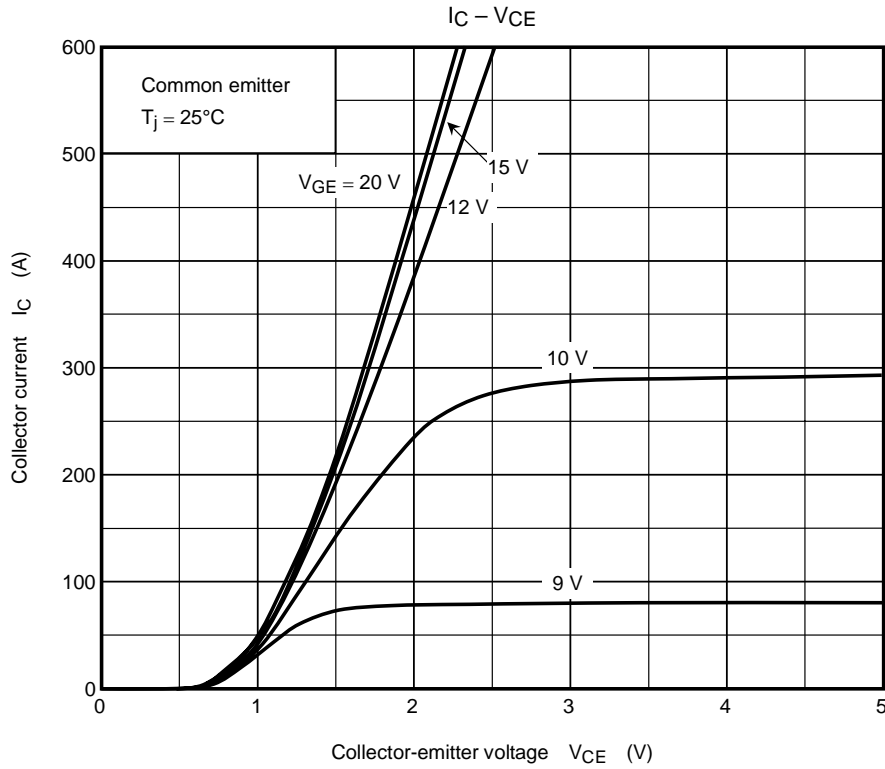

[www.BDTIC.com/MITSUBISHI](http://www.BDTIC.com/MITSUBISHI)

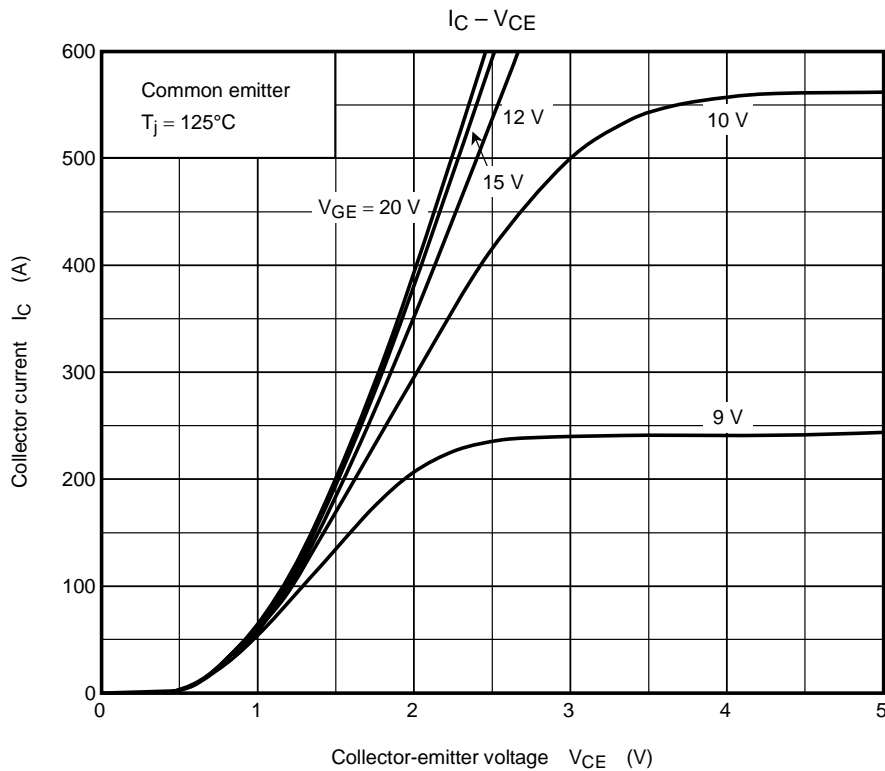

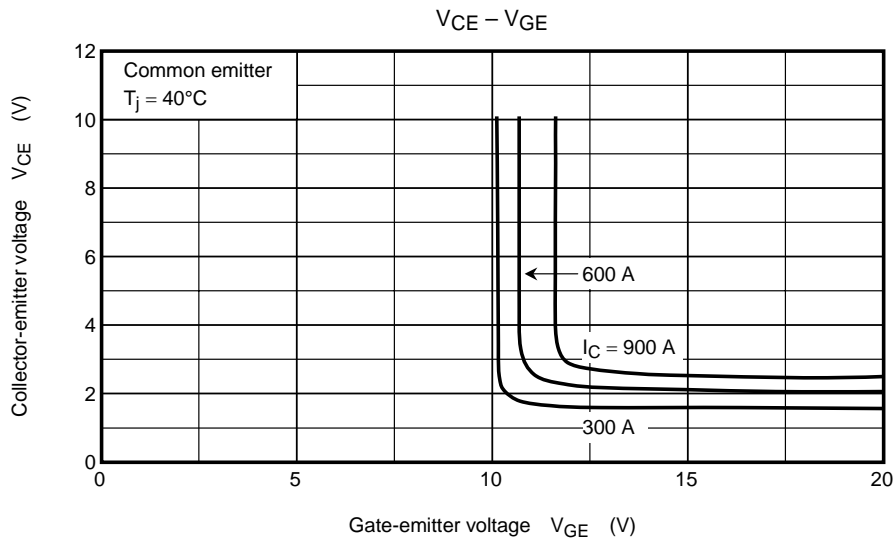
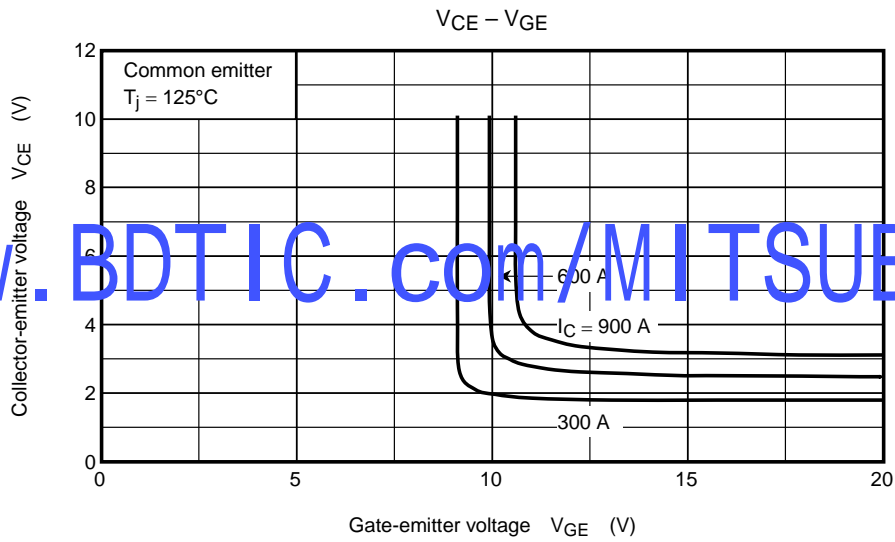
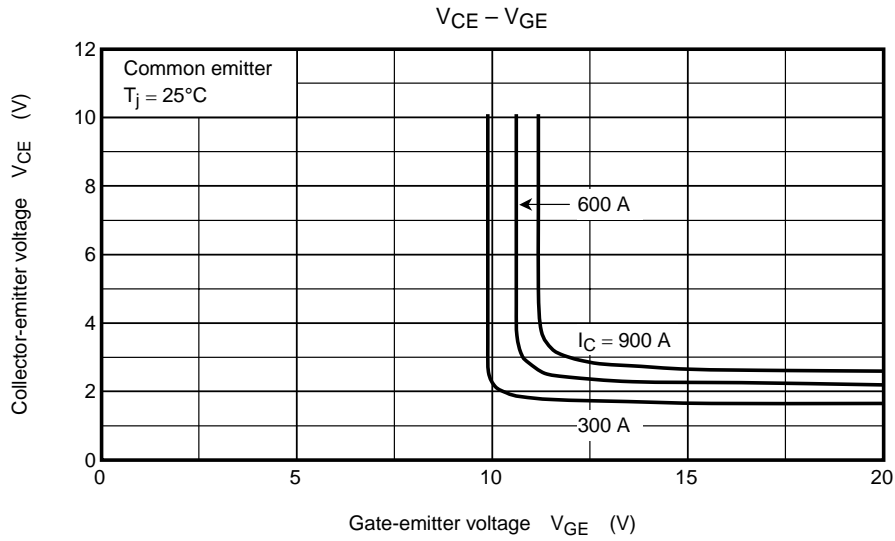

[www.BDTIC.com/MITSUBISHI](http://www.BDTIC.com/MITSUBISHI)

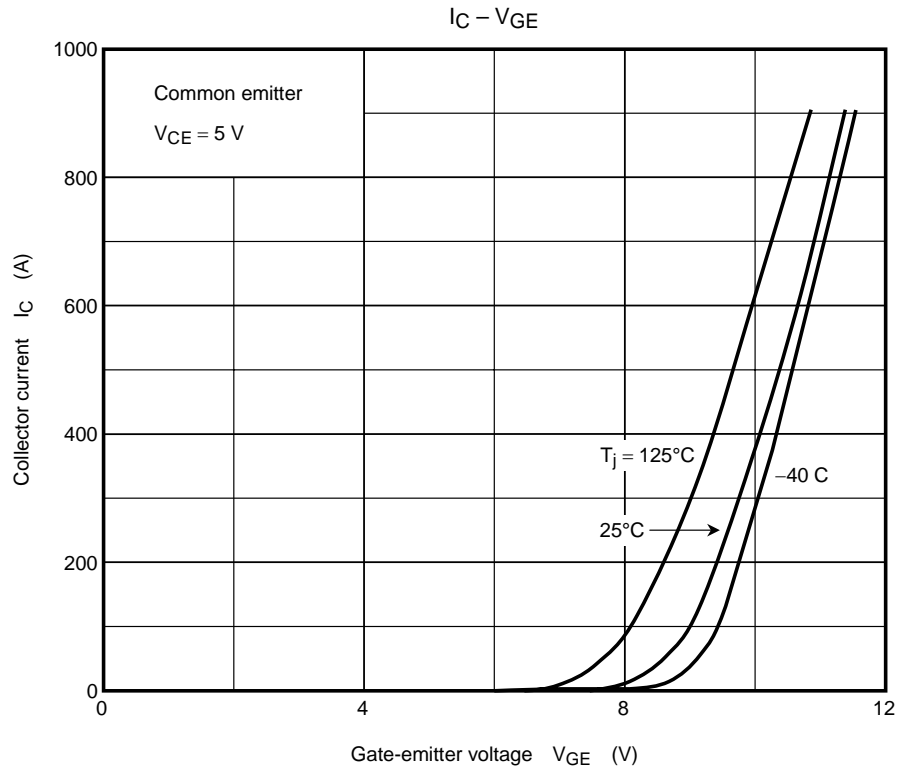

[www.BDTIC.com/MITSUBISHI](http://www.BDTIC.com/MITSUBISHI)

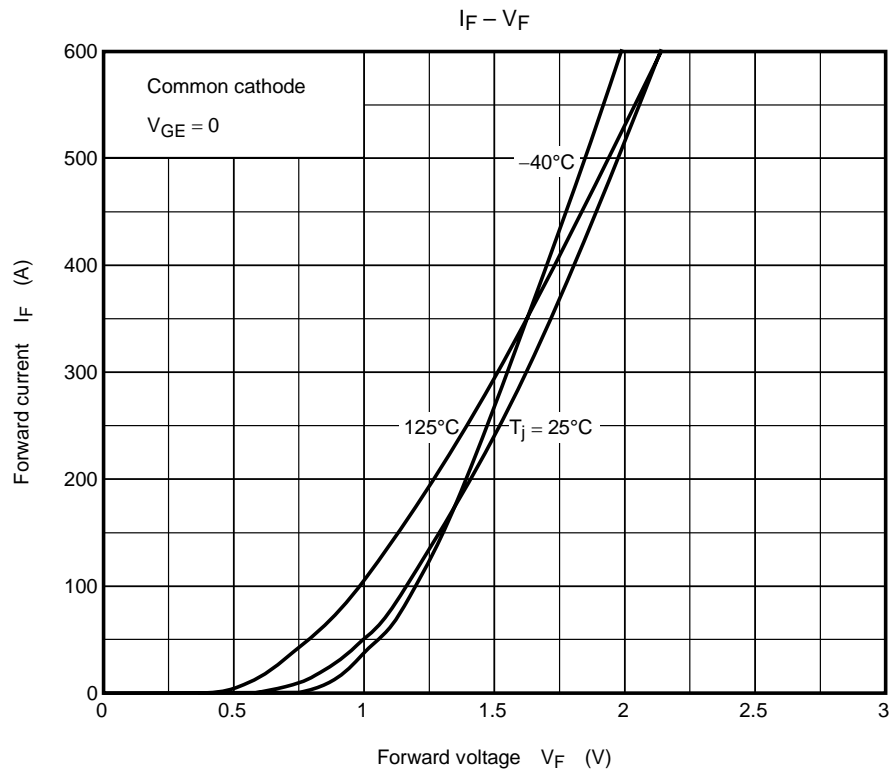



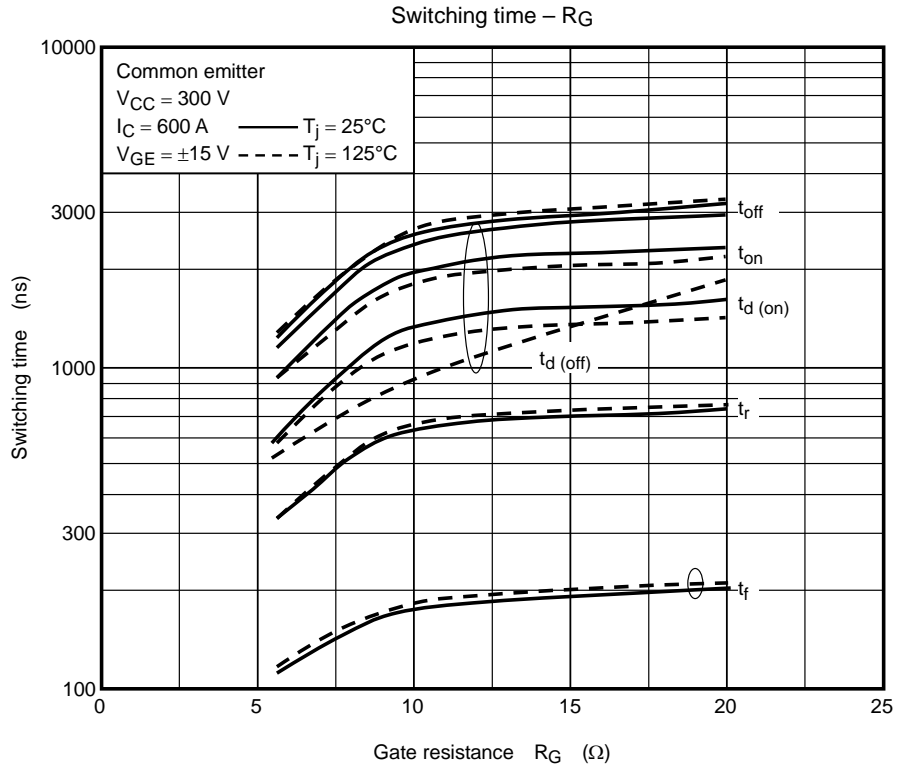

[www.BDTIC.com/MITSUBISHI](http://www.BDTIC.com/MITSUBISHI)

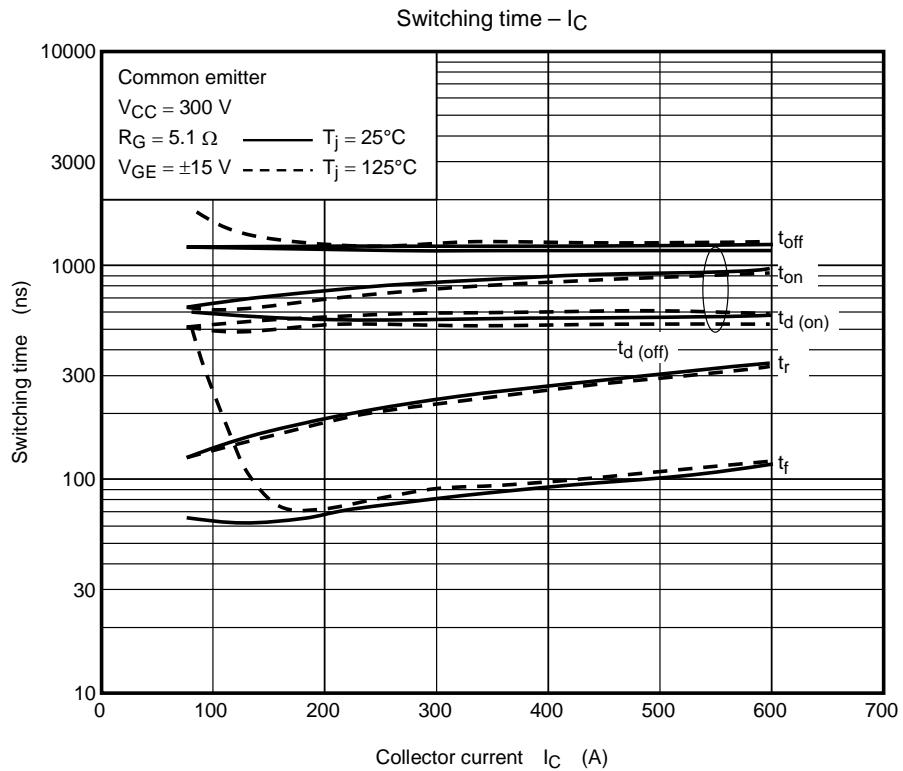

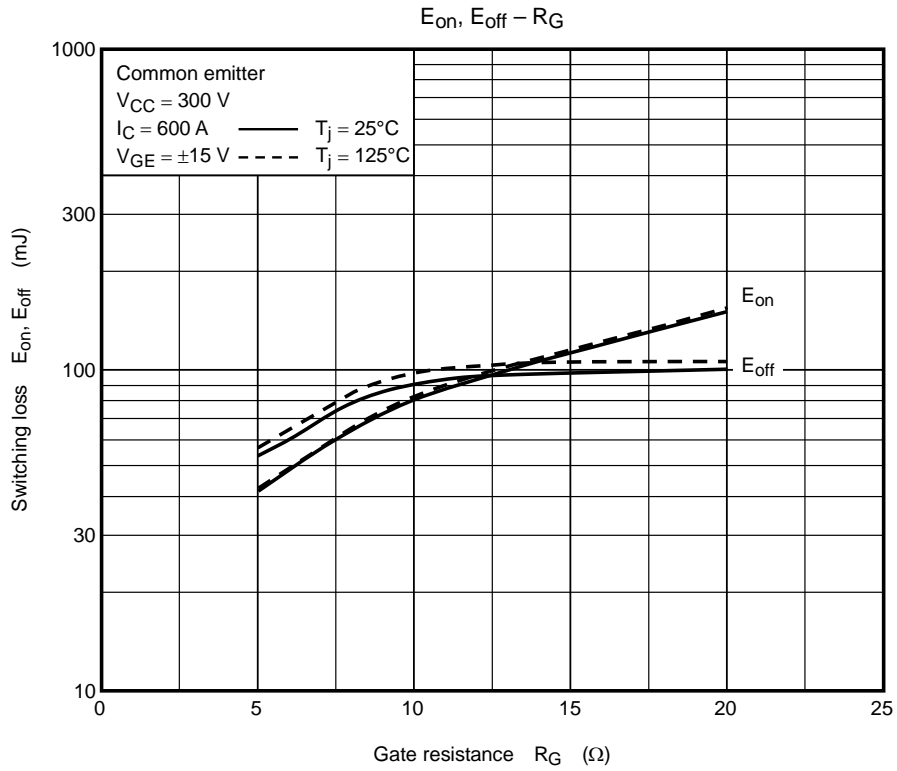

[www.BDTIC.com/MITSUBISHI](http://www.BDTIC.com/MITSUBISHI)

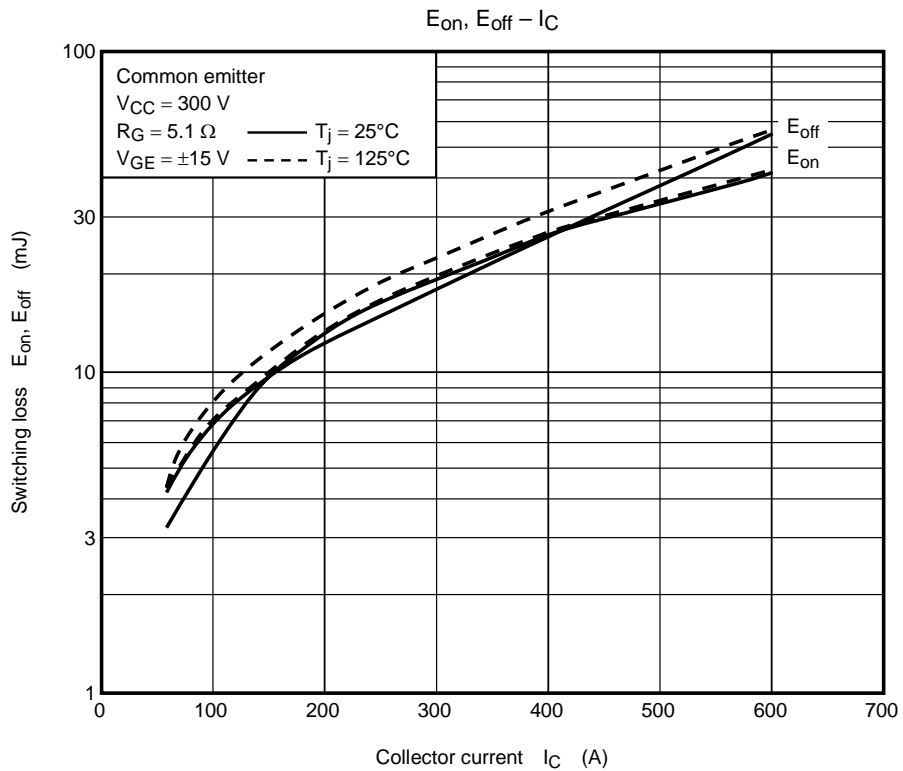

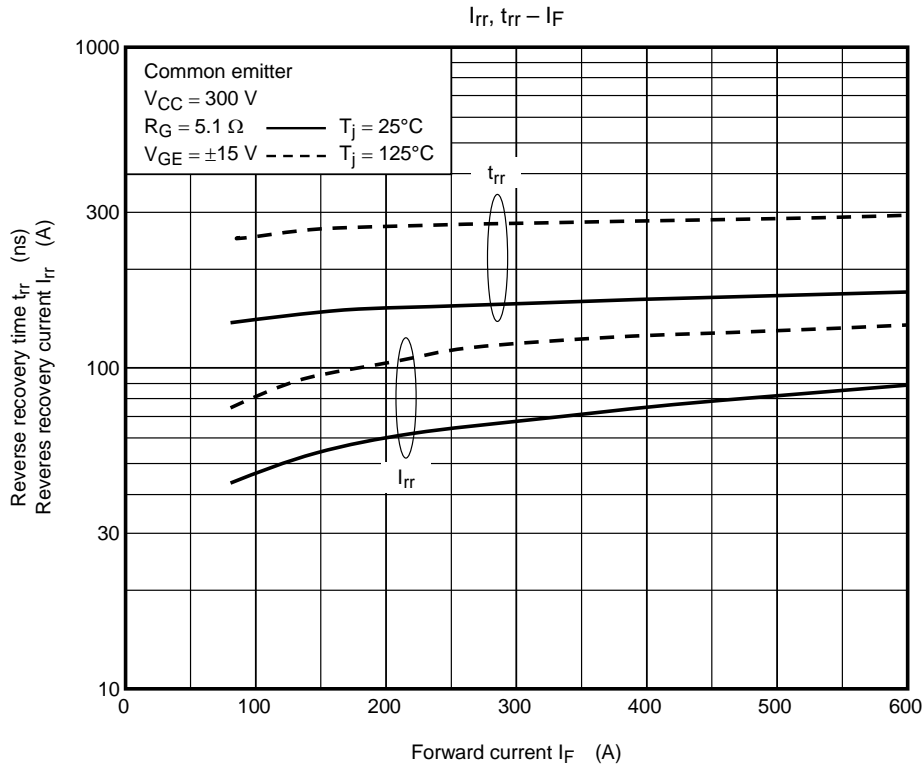

[www.BDTIC.com/MITSUBISHI](http://www.BDTIC.com/MITSUBISHI)

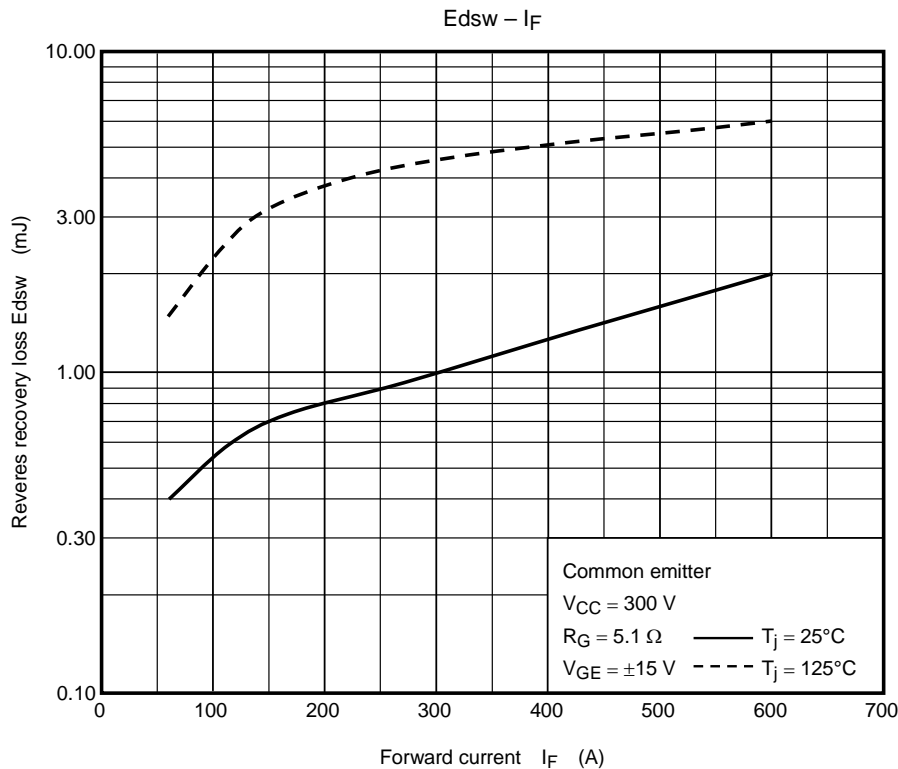

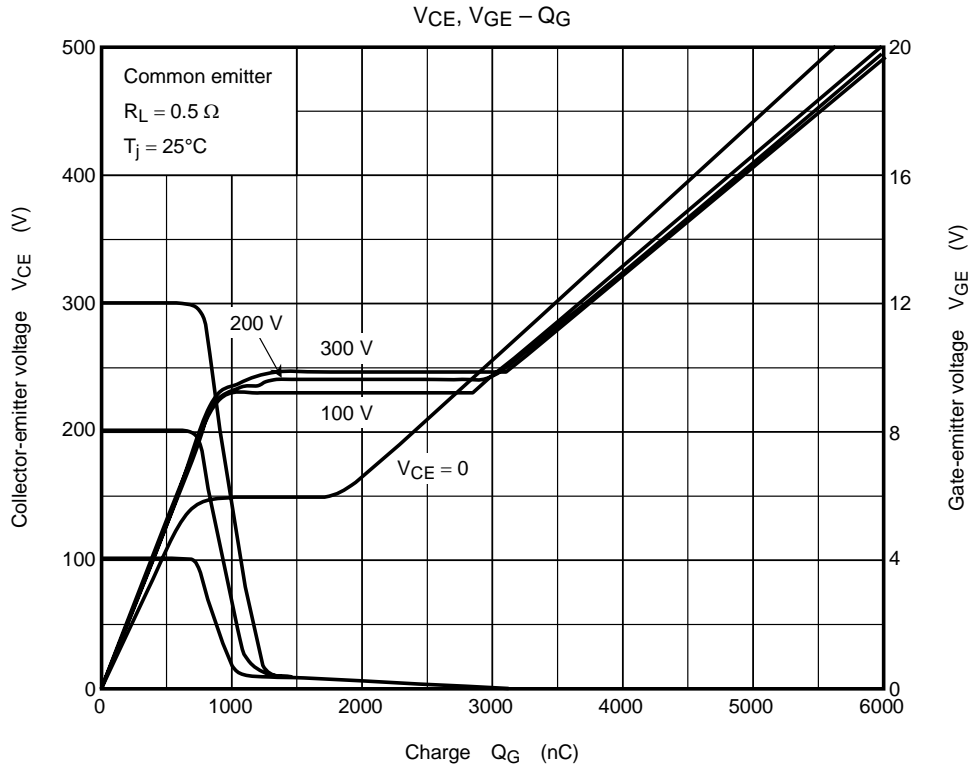

[www.BDTIC.com/MITSUBISHI](http://www.BDTIC.com/MITSUBISHI)

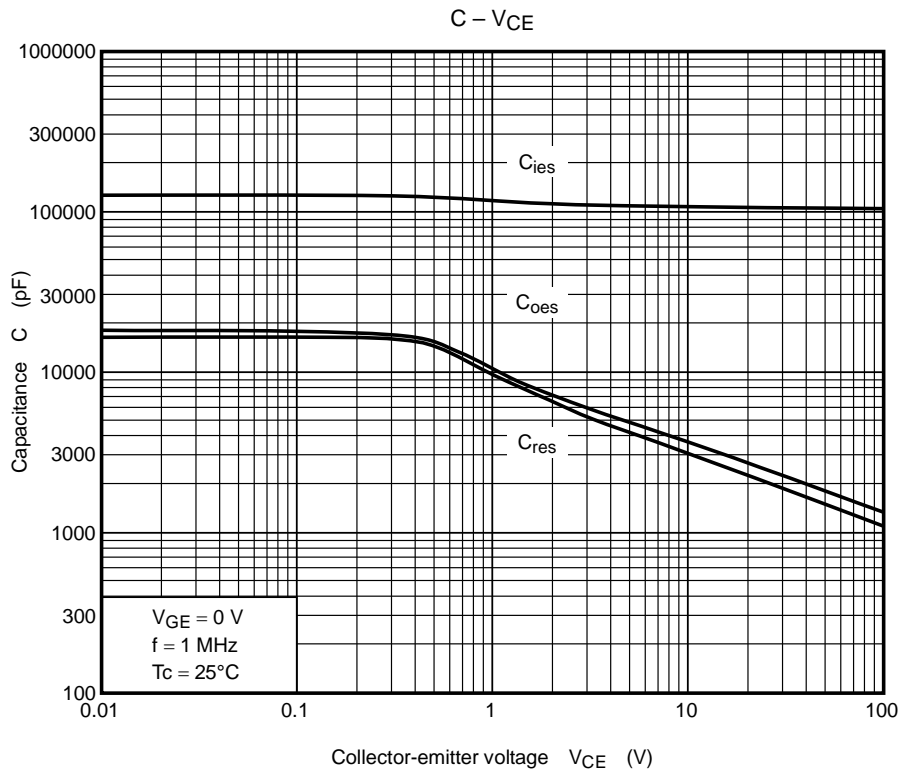

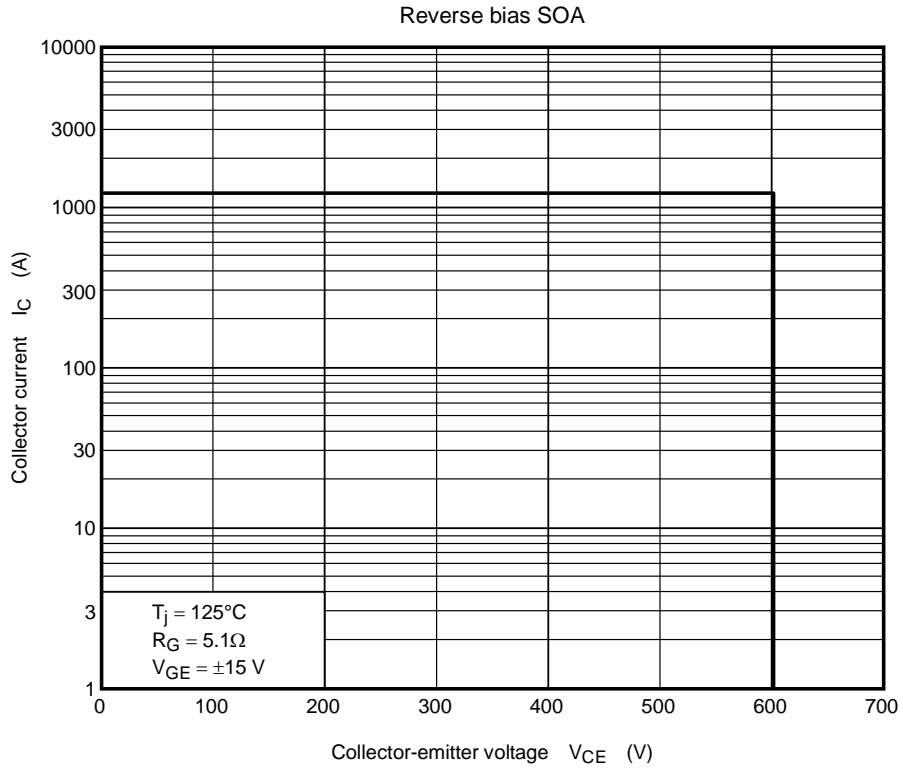

[www.BDTIC.com/MITSUBISHI](http://www.BDTIC.com/MITSUBISHI)

