

CONFIDENTIAL

(This is a RED INK Stamp)

PS21963-AST

Transfer-Mold Type
Insulated Type

Pre.	Shang T.sakai, T.Nakano	Rev.	
Apr.	T.Iwagami 28 Jul-09		

NOT TO BE REPRODUCED OR DISCLOSED WITHOUT SPECIFIC
 WRITTEN PERMISSION OF MITSUBISHI ELECTRIC CORPORATION
 (THIS IS A RED INK STAMP)

Applications : AC100V~240V (DC supply voltage 400V or (less), three phase) low power motor inverter drive.

Integrated Power Functions :

600V/10A low-loss 5th generation IGBT inverter bridge with N-side 3 phase output
DC-to-AC power conversion

Integrated drive, protection and system control functions :

- For upper-leg IGBTs : Drive circuit, High voltage high-speed level shifting, Control supply under-voltage (UV) protection.
- For lower-leg IGBTs : Drive circuit, Control supply under-voltage protection (UV), Short circuit protection (SC), Over temperature protection (OT)
- Fault signaling : Corresponding to a SC fault (Lower-leg IGBT), a UV fault (Lower-side supply) or an OT fault (LVIC temperature)
- Input interface : 3~5V line (High Active).
- UL Recognized: Yellow Card No.E80276

Fig. 1 Package Outlines

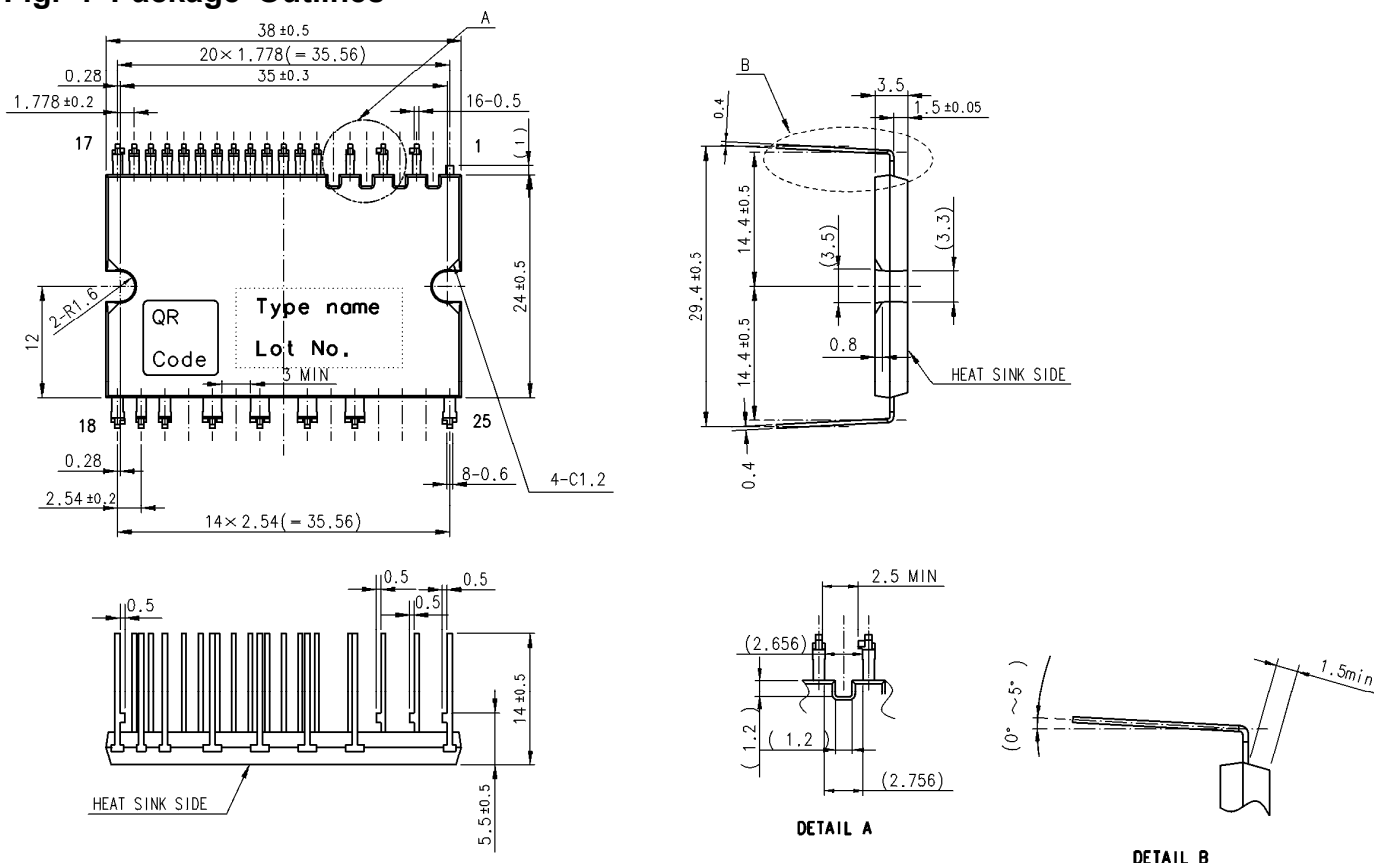

TERMINAL CODE

1	2	3	4	5	6	7	8	9	10	11	12	13
NC	V _{UFB}	V _{VFB}	V _{WFB}	U _P	V _P	W _P	V _{P1}	V _{NC} *	U _N	V _N	W _N	V _{N1}
Fo	CIN	V _{NC} *	NC	NW	NV	NU	W	V	U	P	NC	

*) Please use either one only of the two VNC pins (No.9, 16) for the ground connection and leave another one open.
QR Code is registered trademark of DENSO WAVE INCORPORATED in JAPAN and other countries.

Note: DIIPM is registered trademark of MITSUBISHI ELECTRIC CORPORATION.

CONFIDENTIAL

(This is a RED INK Stamp)

PS21963-ASTTransfer-Mold Type
Insulated TypeMaximum Ratings (T_j=25°C, unless otherwise noted)

Inverter Part

Item	Symbol	Condition	Rating	Unit
Supply voltage	V _{CC}	Applied between P-NU,NV,NW	450	V
Supply voltage (surge)	V _{CC(surge)}	Applied between P-NU,NV,NW	500	V
Collector-emitter voltage	V _{CES}		600	V
Each IGBT collector current	±I _C	T _c =25°C	10	A
Each IGBT collector current (peak)	±I _{CP}	T _c =25°C, less than 1ms	20	A
Collector dissipation	P _C	T _c =25°C, per 1 chip	27.0	W
Junction temperature	T _j	(Note 1)	-20~+125	°C

(Note1) The maximum junction temperature rating of the power chips integrated within the DIPIPM is 150°C(@T_c≤100°C). However, to ensure safe operation of the DIPIPM, the average junction temperature should be limited to T_{j(ave)} ≤125°C (@T_c≤100°C).

Control (Protection) Part

Item	Symbol	Condition	Rating	Unit
Control supply voltage	V _D	Applied between V _{P1} -V _{NC} , V _{N1} -V _{NC}	20	V
Control supply voltage	V _{DB}	Applied between V _{UFB-U} , V _{VFB-V} , V _{WFB-W}	20	V
Input voltage	V _{IN}	Applied between U _P , V _P , W _P -V _{NC} , U _N , V _N , W _N -V _{NC}	-0.5~V _D +0.5	V
Fault output supply voltage	V _{FO}	Applied between FO-V _{NC}	-0.5~V _D +0.5	V
Fault output current	I _{FO}	FO terminal sink current	1	mA
Current sensing input voltage	V _{SC}	Applied between CIN-V _{NC}	-0.5~V _D +0.5	V

Total System

Item	Symbol	Condition	Rating	Unit
Supply voltage self protection limit (short circuit protection capability)	V _{CC(PROT)}	V _D =13.5~16.5V, Inverter part T _j =125°C, non-repetitive less than 2μs	400	V
Module case operation temperature	T _c	(Note2)	-20~+100	°C
Storage temperature	T _{stg}		-40~+125	°C
Isolation voltage	Viso	60Hz, Sinusoidal 1 minute, All connected pins to heat-sink plate	1500	Vrms

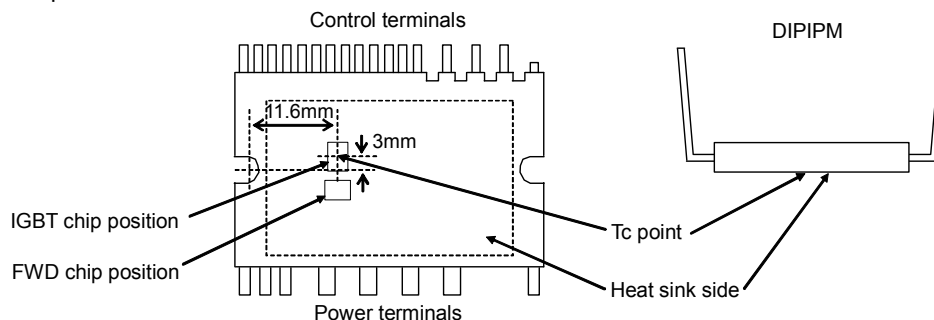
(Note2) T_c measurement position

Thermal Resistance

Item	Symbol	Condition	Min.	Typ.	Max.	Unit
Junction to case thermal resistance (Note3)	R _{th(j-c)Q}	Inverter IGBT part (per 1/6 module)	-	-	3.7	°C/W
	R _{th(j-c)F}	Inverter FWD part (per 1/6 module)	-	-	4.5	

(Note3) Grease with good thermal conductivity and long-term quality should be applied evenly with +100μm~+200μm on the contacting surface of DIPIPM and heat-sink. The contacting thermal resistance between DIPIPM case and heat sink (R_{th(c-f)}) is determined by the thickness and the thermal conductivity of the applied grease. For reference, R_{th(c-f)} (per 1/6 module) is about 0.3°C/W when the grease thickness is 20μm and the thermal conductivity is 1.0W/m·k

DIPIPM	DPH-7153e	http://www.BDTIC.com/MITSUBISHI
--------	-----------	-------------------------------------------------------------------------------

CONFIDENTIAL

(This is a RED INK Stamp)

PS21963-ASTTransfer-Mold Type
Insulated Type

Electrical Characteristics (Tj=25°C, unless otherwise noted.)

Inverter Part

Item	Symbol	Condition	Min.	Typ.	Max.	Unit	
Collector-emitter saturation voltage	V _{CE(sat)}	V _D =V _{DB} =15V	Tj=25°C	-	1.70	2.20	V
		I _C =10A, V _{IN} =5V	Tj=125°C	-	1.80	2.30	
FWD forward voltage	V _{EC}	-I _C =10A, V _{IN} =0V	-	1.70	2.20	V	
Switching times	t _{on}	V _{CC} =300V, V _D =V _{DB} =15V	0.60	1.10	1.70	μs	
	t _{rr}	I _C =10A, Tj=125°C	-	0.30	-		
	t _{c(on)}	V _{IN} =0-5V	-	0.40	0.60		
	t _{off}	Inductive load	-	1.50	2.10		
	t _{c(off)}		-	0.50	0.80		
Collector-emitter cut-off current	I _{CES}	V _{CE} =V _{CES}	Tj=25°C	-	-	1	mA
			Tj=125°C	-	-	10	

Control (Protection) Part

Item	Symbol	Condition	Min.	Typ.	Max.	Unit	
Circuit current	I _D	V _D =V _{DB} =15V	Total of V _{P1} -V _{NC} , V _{N1} -V _{NC}	-	-	2.80	mA
		V _{IN} =5V	V _{UFB} -U, V _{VFB} -V, V _{WFB} -W	-	-	0.55	
		V _D =V _{DB} =15V	Total of V _{P1} -V _{NC} , V _{N1} -V _{NC}	-	-	2.80	
		V _{IN} =0V	V _{UFB} -U, V _{VFB} -V, V _{WFB} -W	-	-	0.55	
Fault output voltage	V _{FOH}	V _{SC} =0V, Fo terminal pull-up to 5V by 10kΩ	4.9	-	-	V	
	V _{FOL}	V _{SC} =1V, I _{FO} =1mA	-	-	0.95		
Input current	I _{IN}	V _{IN} =5V	0.70	1.00	1.50	mA	
Short circuit trip level	V _{SC(ref)}	V _D =15V (Note4)	0.43	0.48	0.53	V	
Over temperature protection (Note5)	OT _i	V _D =15V, Trip level	100	120	140	°C	
	OT _{rh}	At temperature of LVIC Trip/reset hysteresis	-	10	-		
Control supply under-voltage protection	UV _{DBt}	Tj≤125°C	Trip level	10.0	-	12.0	V
	UV _{DBr}		Reset level	10.5	-	12.5	
	UV _{Dt}		Trip level	10.3	-	12.5	
	UV _{Dr}		Reset level	10.8	-	13.0	
Fault output pulse width	t _{FO}	(Note6)	20	-	-	μs	
ON threshold voltage	V _{th(on)}	Applied between U _P , V _P , W _P , U _N , V _N , W _N -V _{NC}	-	2.1	2.6	V	
OFF threshold voltage	V _{th(off)}		0.8	1.3	-		
ON/OFF threshold hysteresis voltage	V _{th(hys)}		0.35	0.65	-		

(Note4) Short circuit protection is functioning only for the lower-arms. Please select the external shunt resistance such that the SC trip-level is less than 1.7 times of the current rating.

(Note5) Over temperature protection(OT) outputs fault signal, when the LVIC temperature exceeds OT trip temperature level(OT_i). In that case if the heat sink comes off DIPIPM or fixed loosely, don't reuse that DIPIPM. (There is a possibility that junction temperature of power chips exceeded maximum Tj(150°C).

(Note6) Fault signal is asserted only corresponding to a SC, a UV or an OT failure at lower side, and the Fo pulse width is different for each failure modes. For SC failure, Fo output is with a fixed width of 20μsec(min), but for UV or OT failure, Fo output continuously during the whole UV or OT period, however, the minimum Fo pulse width is 20μsec(min) for very short UV or OT period less than 20μsec.

CONFIDENTIAL

(This is a RED INK Stamp)

PS21963-ASTTransfer-Mold Type
Insulated Type

Mechanical Characteristics and Ratings

Item	Condition	Min.	Typ.	Max.	Unit
Mounting torque	Mounting screw: M3 (Note 7) Recommended: 0.69N·m	0.59	-	0.78	N·m
Weight		-	10	-	g
Heat-sink flatness	(Note 8)	-50	-	+100	μm

(Note 7) Plain washers (ISO 7089~7094) are recommended.

(Note 8) Flatness measurement position:

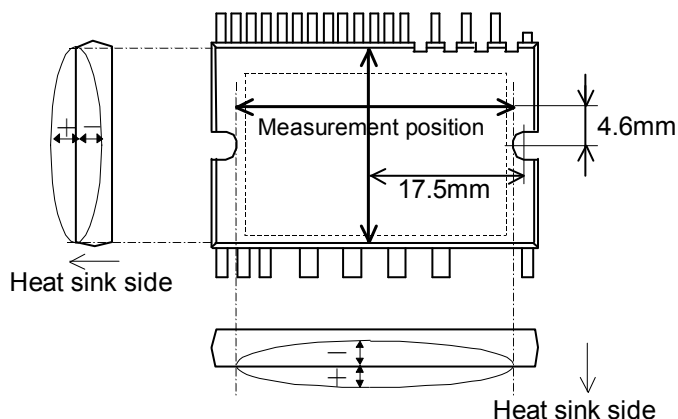

Recommended Operation Conditions

Item	Symbol	Condition	Recommended			Unit	
			Min.	Typ.	Max.		
Supply voltage	V_{CC}	Applied between P-NU,NV,NW	0	300	400	V	
Control supply voltage	V_D	Applied between $V_{P1}-V_{NC}, V_{N1}-V_{NC}$	13.5	15.0	16.5	V	
Control supply voltage	V_{DB}	Applied between $V_{UFB-U}, V_{VFB-V}, V_{WFB-W}$	13.0	15.0	18.5	V	
Control supply variation	$\Delta V_D, \Delta V_{DB}$		-1	-	1	V/μs	
Arm-shoot-through blocking time	t_{dead}	For each input signal, $T_c \leq 100^\circ\text{C}$	1.5	-	-	μs	
Allowable r.m.s. current	I_o	$V_{CC}=300\text{V}, V_D=V_{DB}=15\text{V},$ P.F=0.8, sinusoidal PWM, $T_j \leq 125^\circ\text{C}, T_c \leq 100^\circ\text{C}$ (Note 9)	$f_{PWM}=5\text{kHz}$	-	-	5.0	Arms
			$f_{PWM}=15\text{kHz}$	-	-	3.0	
Allowable minimum input pulse width	PWIN(on)	(Note 10)	0.5	-	-	μs	
	PWIN(off)		0.5	-	-		
V_{NC} variation	V_{NC}	Between $V_{NC}-\text{NU}, \text{NV}, \text{NW}$ (including surge)	-5.0	-	5.0	V	

(Note 9) The allowable r.m.s. current also depends on the actual application conditions.

(Note 10) DIPIPM might not make response or work properly if the input signal pulse width is less than the recommended minimum value.

CONFIDENTIAL

(This is a RED INK Stamp)

PS21963-AST

Transfer-Mold Type
Insulated Type

Fig.2 DIIPM Internal Circuit:

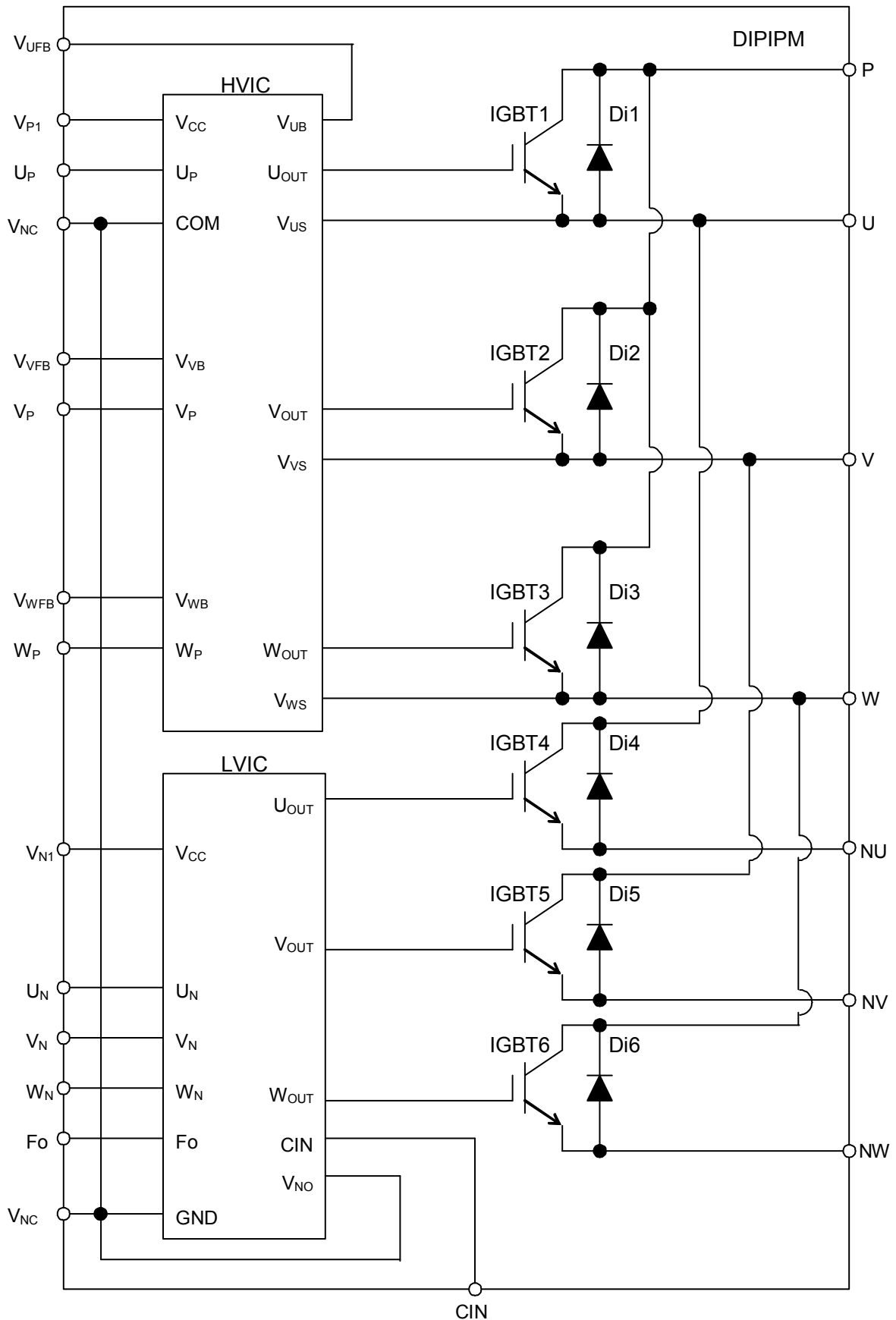

CONFIDENTIAL

(This is a RED INK Stamp)

PS21963-ASTTransfer-Mold Type
Insulated Type**Fig.3 Timing Chart of the DIIPM Protective Functions**

[A] Short-Circuit Protection (Lower-arms only with the external shunt resistor and RC filter)

- a1. Normal operation: IGBT ON and carrying current.
- a2. Short circuit detection (SC trigger).
- a3. IGBT gate hard interruption.
- a4. IGBT turns OFF.
- a5. Fo outputs ($t_{FO(min)}=20\mu s$).
- a6. Input = "L". IGBT OFF.
- a7. Input = "H".
- a8. IGBT OFF in spite of "H" input.

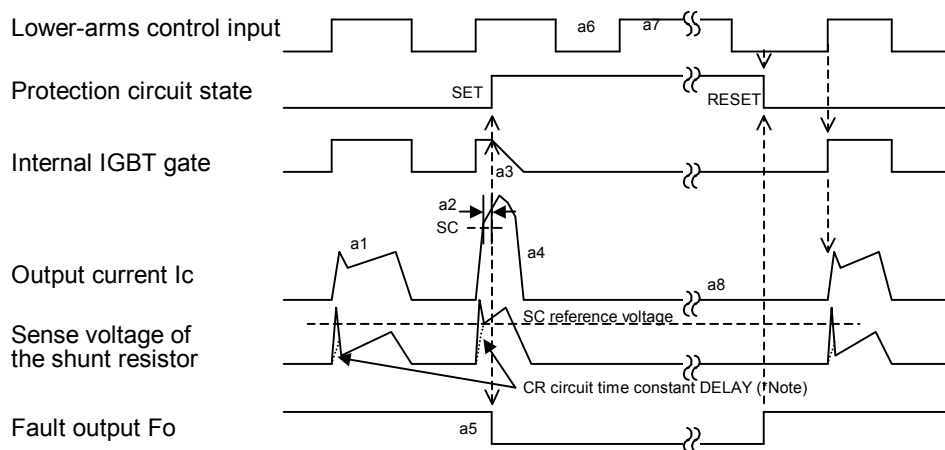
[B] Under Voltage Protection (Lower-side, UV_D)

- b1. Control supply voltage rising: After the voltage level reaches UV_{Dr} , the circuits start to operate when next input is applied.
- b2. Normal operation : IGBT ON and carrying current.
- b3. Under voltage trip (UV_{Dt}).
- b4. IGBT OFF in spite of control input condition.
- b5. Fo outputs($t_{FO} \geq 20\mu s$ and Fo outputs continuously during UV period.)
- b6. Under voltage reset (UV_{Dr}).
- b7. Normal operation : IGBT ON and carrying current.

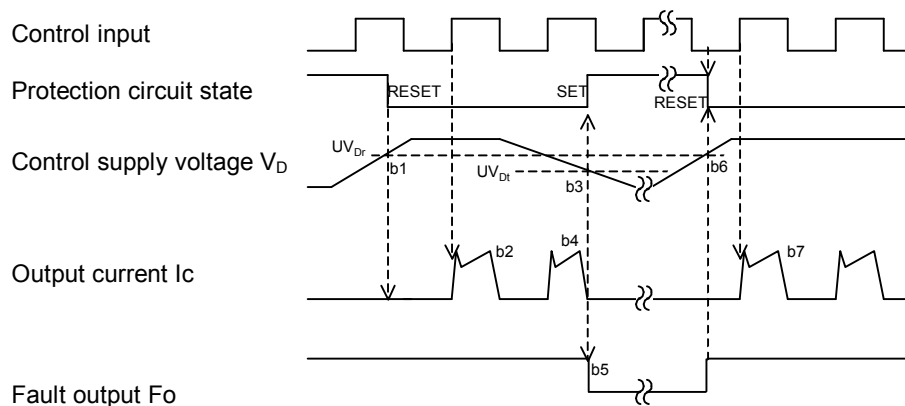

CONFIDENTIAL

(This is a RED INK Stamp)

PS21963-ASTTransfer-Mold Type
Insulated Type**[C] Under- Voltage Protection (Upper-side, UV_{DB})**

- c1. Control supply voltage rises : After the voltage reaches UV_{DBr} , the circuits start to operate when next input is applied.
- c2. Normal operation : IGBT ON and carrying current.
- c3. Under voltage trip (UV_{DBt}).
- c4. IGBT OFF in spite of control input signal level, but there is no F_o signal outputs.
- c5. Under voltage reset (UV_{DBr}).
- c6. Normal operation : IGBT ON and carrying current.

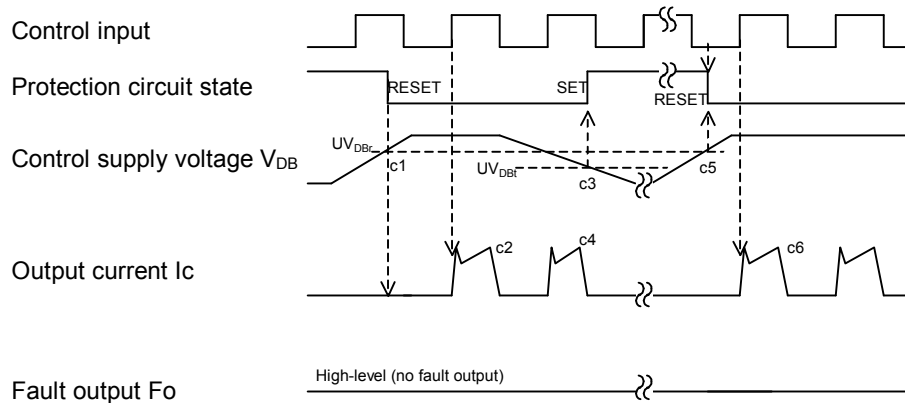
**[D] Over Temperature Protection (Lower-side, OT)**

- d1. Normal operation : IGBT ON and carrying current
- d2. LVIC temperature exceeds over temperature trip level(OT_t).
- d3. IGBT OFF in spite of control input condition.
- d4. F_o outputs during over temperature period, however, the minimum pulse width is $20\mu s$.
- d5. LVIC temperature becomes under over temperature reset level.
- d6. Circuits start to operate normally when next input is applied.

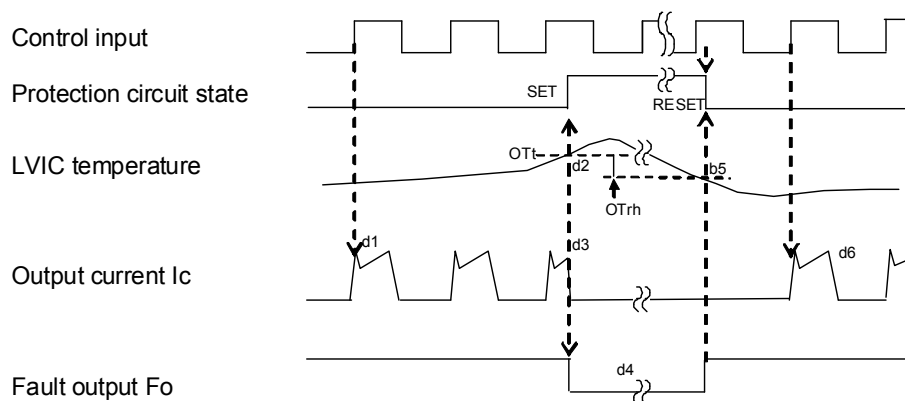

CONFIDENTIAL

(This is a RED INK Stamp)

PS21963-AST

Transfer-Mold Type
Insulated Type

Fig.4 A Instance of Interface Circuit

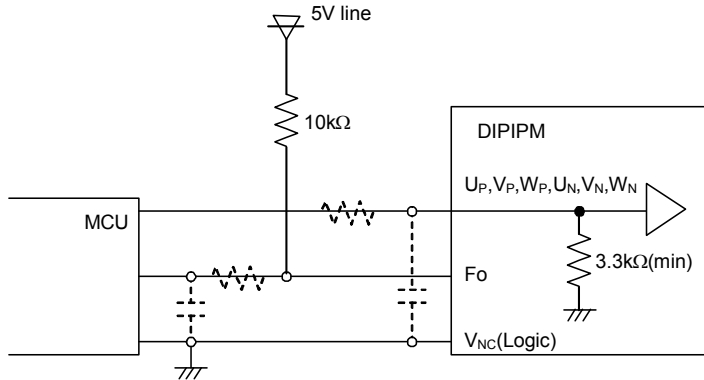

Note:

1. The setting of RC coupling at each input (parts shown dotted) depends on the PWM control scheme and the wiring impedance of the printed circuit board.
2. The DIP-IPM input section integrates a 3.3kΩ(min) pull-down resistor. Therefore, when using an external filtering resistor, pay attention to the turn-on threshold voltage.

Fig.5 Pattern Wiring Around the Shunt Resistor

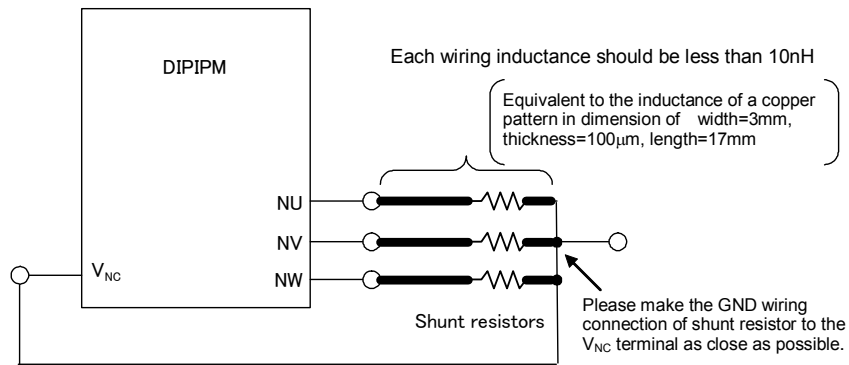

CONFIDENTIAL

(This is a RED INK Stamp)

PS21963-AST

Transfer-Mold Type
Insulated Type

Fig.6 Example of Application Circuit

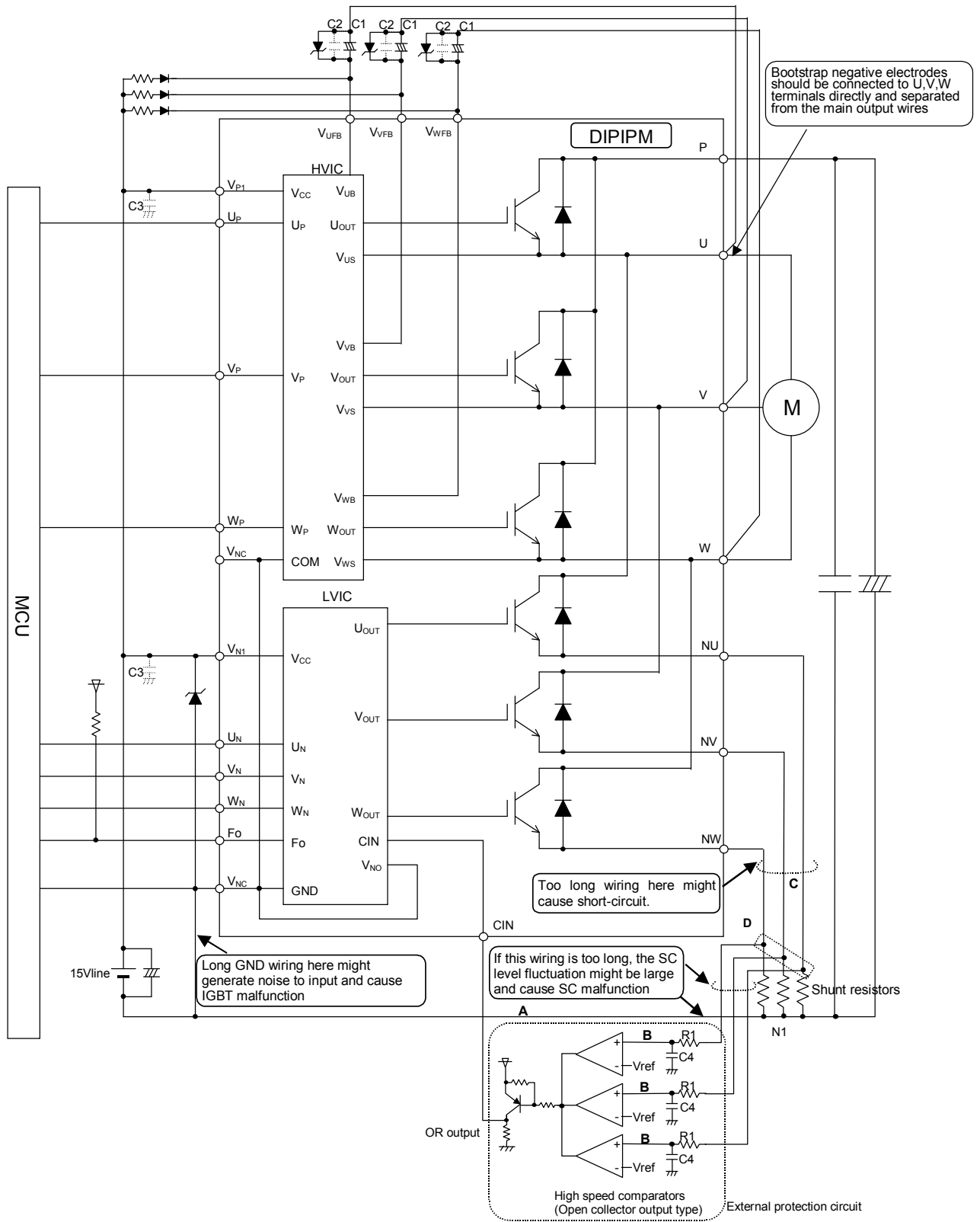

CONFIDENTIAL

(This is a RED INK Stamp)

PS21963-AST**Transfer-Mold Type
Insulated Type****Note:**

- (1) If control GND is connected with power GND by common broad pattern, it may cause malfunction by power GND fluctuation. It is recommended to connect control GND and power GND at only a point N1 (near the terminal of shunt resistor).
- (2) It is recommended to insert a Zener diode (24V/1W) between each pair of control supply terminals to prevent surge destruction.
- (3) To prevent surge destruction, the wiring between the smoothing capacitor and the P, N1 terminals should be as short as possible. Generally a 0.1 μ -0.22 μ F snubber between the P-N1 terminals is recommended.
- (4) If high frequency noise superimposed to the control supply line, IC malfunction might happen and cause DIPIPM erroneous operation. To avoid such problem happens, line ripple voltage should meet the following specifications: $dV/dt \leq \pm 1V/\mu s$, $V_{ripple} \leq 2V_{p-p}$.
- (5) Select the time constant R1C4 in the range of 1.5 μ -2 μ s and high speed comparators for the external protection circuit. SC interrupting time might vary with the wiring pattern. Tight tolerance, temp-compensated type is recommended for R1, C4.
- (6) The threshold voltage Vref of comparators should be set up the same rating of short circuit trip level (Vsc(ref): min.0.43V to max.0.53V).
- (7) OR output high level should be over 0.53V (=maximum Vsc(ref)).
- (8) Select the shunt resistance such that the SC trip-level is less than specified value. (The rating current x1.7)
- (9) All capacitors should be mounted as close to the terminals of DIPIPM as possible. (C1: good temperature, frequency characteristic electrolytic type, and C2, C3 : 0.22 μ -2 μ F, good temperature, frequency and DC bias characteristic ceramic type are recommended.)
- (10) To prevent malfunction, the wiring of A, B, C should be as short as possible.
- (11) The point D at which the wiring to comparator is divided should be at near the terminal of shunt resistor.
- (12) High voltage (VRRM =600V or more) and fast recovery type (t_{rr} =100ns or less) diodes should be used in the bootstrap circuit.
- (13) Fo output is open drain type. It should be pulled up to the MCU or control power supply (e.g. 5V, 15V) by a resistor that makes I_{F0} up to 1mA.
- (14) Thanks to HVIC inside the module, direct coupling to MCU without any opto-coupler or transformer isolation is possible.
- (15) Input drive is High-active type. There is a 3.3k Ω (Min.) pull-down resistor in the input circuit of IC. To prevent malfunction, the wiring of each input should be as short as possible. When using RC coupling circuit, make sure the input signal level meet the turn-on and turn-off threshold voltage.
- (16) Two VNC terminals (9 & 16 pin) are connected inside DIPIPM, please connect either one to the 15V power supply GND outside and leave another one open.

CONFIDENTIAL

(This is a RED INK Stamp)

PS21963-ASTTransfer-Mold Type
Insulated Type**Keep safety first in your circuit designs!**

Mitsubishi Electric Corporation puts the maximum effort into making semiconductor products better and more reliable, but these are always the possibility that trouble may occur with them. Trouble with semiconductors may lead to personal injury, fire or property damage. Remember to give due consideration to safety when making your circuit designs, with appropriate measures such as (1) placement of substitutive, auxiliary circuits, (2) use of non-flammable material or (3) prevention against any malfunction or mishap.

Notice regarding these materials

These materials are intended as reference to assist our customers in the selection of the Mitsubishi semiconductor product best suited to the customer's application; they do not convey any license under any intellectual property rights, or any other rights, belonging to Mitsubishi Electric Corporation or third party.

Mitsubishi Electric Corporation assumes no responsibility for any damage, or infringement of any third-party's rights, originating in the use of any product data, diagrams, chart, programs, algorithms, or circuit application examples contained in these materials.

All information contained in these materials, including product data, diagrams, charts, programs and algorithms represents information on products at the time of publication of these materials, and are subject to change by Mitsubishi Electric Corporation without notice due to product improvements or other reasons.

It is therefore recommended that customers contact Mitsubishi Electric Corporation or an authorized Mitsubishi Semiconductor product distributor for the latest product information before purchasing a product listed herein.

The information described here may contain inaccuracies or typographical errors. Mitsubishi Electric Corporation assumes no responsibility for any damage, liability, or other loss rising from these inaccuracies or errors.

Please also pay attention to information published by Mitsubishi Electric Corporation by various means, including the Mitsubishi Semiconductor home page (<http://www.mitsubishichips.com>)

When using any or all of the information contained in these materials, including product data, diagrams, charts, programs and algorithms, please be sure to evaluate all information as a total system before making a final decision on the applicability of the information and products. Mitsubishi Electric Corporation assumes no responsibility for any damage, liability or other loss resulting from the information contained herein.

Mitsubishi Electric Corporation semiconductors are not designed or manufactured for use in a device or system that is used under circumstances in which human life is potentially at stake. Please contact Mitsubishi Electric Corporation or an authorized Mitsubishi Semiconductor product distributor when considering the use of a product contained herein for any specific purposes, such as apparatus or systems for transportation, vehicular, medical, aerospace, nuclear, or undersea repeater use.

The prior written approval of Mitsubishi Electric Corporation is necessary to reprint or reproduce in whole or in part these materials.

If these products or technologies are subject to the Japanese export control restrictions, they must be exported under a license from the Japanese government and cannot be imported into a country other than the approved destination. Any diversion or reexport contrary to the export control laws and regulations of Japan and/or the country of destination is prohibited.

Please contact Mitsubishi Electric Corporation or an authorized Mitsubishi Semiconductor product distributor for further details on these materials or the products contained therein.