



Features

- Excellent Linearity
- Superior Return Loss Performance
- Extremely Low Distortion
- Optimal Reliability
- Low Noise
- Unconditionally Stable Under All Terminations
- 28.3dB Typical Gain at 200MHz
- 140mA Maximum at 24V_{DC}

Applications

- 5 MHz to 200MHz CATV Amplifier For Reverse Channel Systems

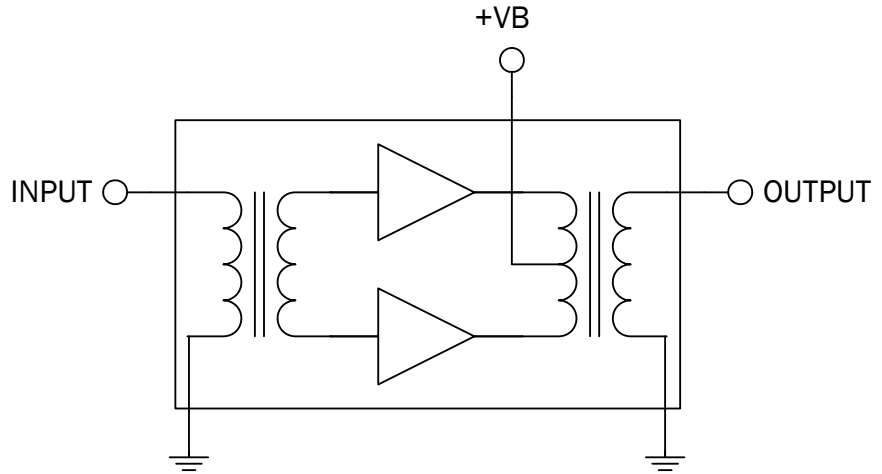

Functional Block Diagram

Product Description

The R2005280L is a hybrid reverse amplifier. The part employs a silicon die. It has extremely low distortion and superior return loss performance. The part also provides optimal reliability with low noise and is well suited for 5 MHz to 200MHz CATV amplifiers for reverse channel systems.

Optimum Technology Matching® Applied

- | | | | |
|--------------------------------------|--------------------------------------|--------------------------------------------|------------------------------------|
| <input type="checkbox"/> GaAs HBT | <input type="checkbox"/> SiGe BiCMOS | <input type="checkbox"/> GaAs pHEMT | <input type="checkbox"/> GaN HEMT |
| <input type="checkbox"/> GaAs MESFET | <input type="checkbox"/> Si BiCMOS | <input type="checkbox"/> Si CMOS | <input type="checkbox"/> BiFET HBT |
| <input type="checkbox"/> InGaP HBT | <input type="checkbox"/> SiGe HBT | <input checked="" type="checkbox"/> Si BJT | <input type="checkbox"/> LDMOS |

RF MICRO DEVICES®, RFMD®, Optimum Technology Matching®, Enabling Wireless Connectivity™, PowerStar®, POLARIS™ TOTAL RADIO™ and UltimateBlue™ are trademarks of RFMD, LLC. BLUETOOTH is a trademark owned by Bluetooth SIG, Inc., U.S.A. and licensed for use by RFMD. All other trade names, trademarks and registered trademarks are the property of their respective owners. ©2006, RF Micro Devices, Inc.

Absolute Maximum Ratings

Parameter	Rating	Unit
RF Input Voltage (single tone)	65	dBmV
DC Supply Over-Voltage (5 minutes)	30	V
Storage Temperature	-40 to +100	°C
Operating Mounting Base Temperature	-30 to +100	°C



Caution! ESD sensitive device.

Exceeding any one or a combination of the Absolute Maximum Rating conditions may cause permanent damage to the device. Extended application of Absolute Maximum Rating conditions to the device may reduce device reliability. Specified typical performance or functional operation of the device under Absolute Maximum Rating conditions is not implied.

The information in this publication is believed to be accurate and reliable. However, no responsibility is assumed by RF Micro Devices, Inc. ("RFMD") for its use, nor for any infringement of patents, or other rights of third parties, resulting from its use. No license is granted by implication or otherwise under any patent or patent rights of RFMD. RFMD reserves the right to change component circuitry, recommended application circuitry and specifications at any time without prior notice.



RoHS (Restriction of Hazardous Substances): Compliant per EU Directive 2002/95/EC.

Parameter	Specification			Unit	Condition
	Min.	Typ.	Max.		
Overall					$V_B = 24V; T_{MB} = 30^\circ C; Z_S = Z_L = 75\Omega$
Power Gain	27.5	28.2	28.5	dB	f = 5 MHz
	27.3	28.3		dB	f = 200 MHz
Slope ^[1]	-0.2	0.1	0.5	dB	f = 5 MHz to 200 MHz
Flatness of Frequency Response			±0.3	dB	f = 5 MHz to 200 MHz
Input Return Loss	20.0			dB	f = 5 MHz to 200 MHz
Output Return Loss	20.0			dB	f = 5 MHz to 200 MHz
Noise Figure		4.9	5.2	dB	f = 200 MHz
Total Current Consumption (DC)	130.0	135.0	140.0	mA	
Distortion data 5 MHz to 200 MHz					
CTB			-69	dBc	7 ch flat; $V_O = 50\text{dBmV}^{[2]}$
XMOD			-65	dBc	7 ch flat; $V_O = 50\text{dBmV}^{[2]}$
CSO			-70	dBc	7 ch flat; $V_O = 50\text{dBmV}^{[2]}$
d_2			-60	dBc	^[3]
V_O	61.0			dBmV	$D_{IM} = -60\text{dB}^{[4]}$

- The slope is defined as the difference between the gain at the start frequency and the gain at the stop frequency.
- 7 channels, NTSC frequency raster: T7-T13(7.0MHz to 43.0MHz), 2-6 (55.25MHz - 83.25MHz), A-7 (121.25MHz - 175.25MHz), +50dBmV flat output level.
- $f_1 = 83.25\text{MHz}; V_1 = 50\text{dBmV}; f_2 = 109.25\text{MHz}; V_2 = 50\text{dBmV}; f_{TEST} = f_1 + f_2 = 192.5\text{MHz}.$
- $f_1 = 187.25\text{MHz}; V_1 = 50\text{dBmV}; f_2 = 194.25\text{MHz}; V_2 = V_1 - 6\text{dB}; f_3 = 196.25\text{MHz}; V_3 = V_1 - 6\text{dB}; f_{TEST} = f_1 + f_2 - f_3 = 185.25\text{MHz},$ according to DIN45004B.

Composite Second Order (CSO) - The CSO parameter (both sum and difference products) is defined by the NCTA.

Composite Triple Beat (CTB) - The CTB parameter is defined by the NCTA.

Cross Modulation (XMOD) - Cross modulation (XMOD) is measured at baseband (selective voltmeter method), referenced to 100% modulation of the carrier being tested.

Package Drawing

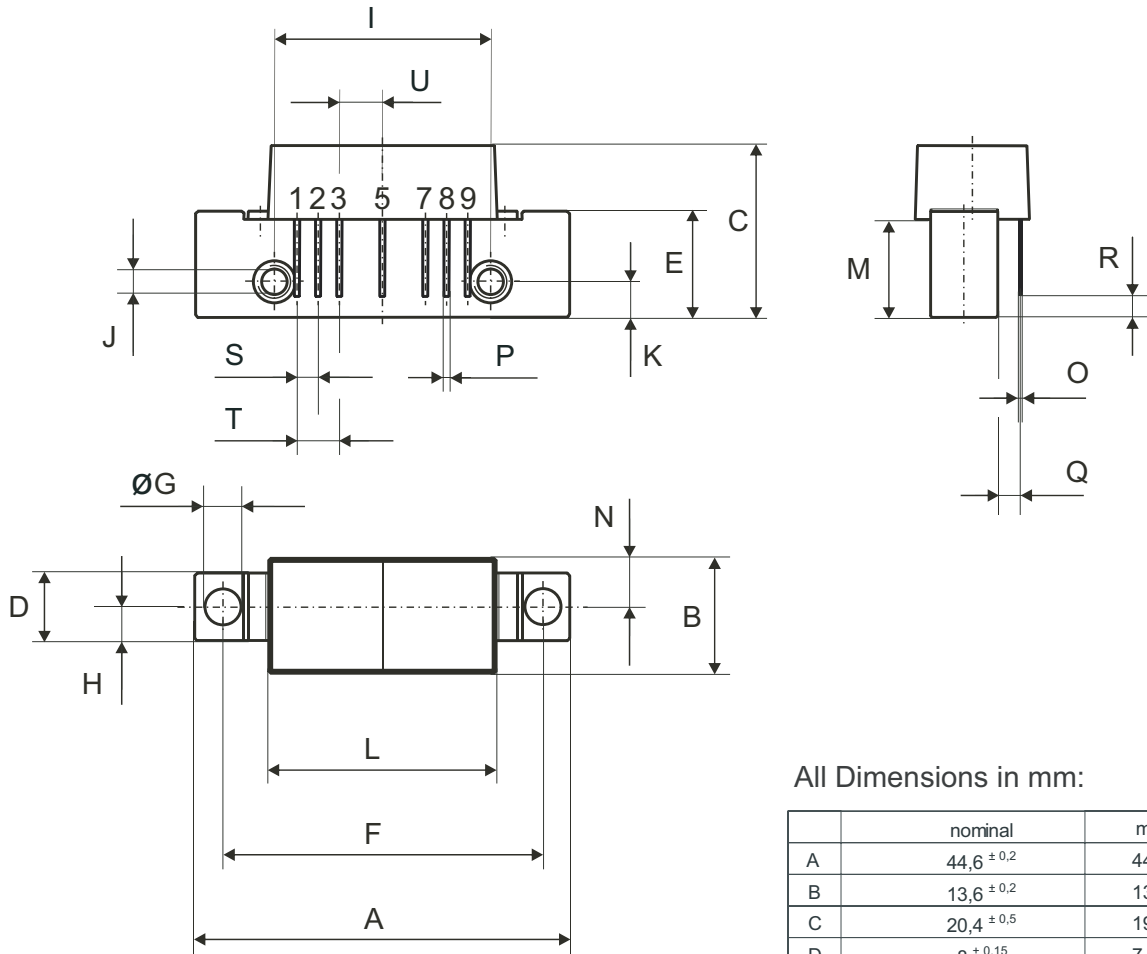

All Dimensions in mm:

	nominal	min	max
A	44,6 ± 0,2	44,4	44,8
B	13,6 ± 0,2	13,4	13,8
C	20,4 ± 0,5	19,9	20,9
D	8 ± 0,15	7,85	8,15
E	12,6 ± 0,15	12,45	12,75
F	38,1 ± 0,2	37,9	38,3
G	4 ^{+0,2 / -0,05}	3,95	4,2
H	4 ± 0,2	3,8	4,2
I	25,4 ± 0,2	25,2	25,6
J	UNC 6-32	-	-
K	4,2 ± 0,2	4,0	4,4
L	27,2 ± 0,2	27,0	27,4
M	11,6 ± 0,5	11,1	12,1
N	5,8 ± 0,4	5,4	6,2
O	0,25 ± 0,02	0,23	0,27
P	0,45 ± 0,03	0,42	0,48
Q	2,54 ± 0,3	2,24	2,84
R	2,54 ± 0,5	2,04	3,04
S	2,54 ± 0,25	2,29	2,79
T	5,08 ± 0,25	4,83	5,33
U	5,08 ± 0,25	4,83	5,33

Pinning:

	1	2	3	4	5	6	7	8	9
	INPUT	GND	GND		+VB		GND	GND	OUTPUT

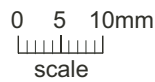

Notes:

