



Features

- Low Frequency - 3.5GHz Operations
- Very Low Insertion Loss:
Cell Band 0.25dB
PCS Band 0.30dB
- High Isolation:
Cell Band 28dB
PCS Band 22dB
- Compatible with Low Voltage Logic: ($V_{HIGH} = 1.8V$)
- Excellent Linearity Performance(IIP2):
Cell Band 110dBm
PCS Band 110dBm
- Lowest BOM Cost and Small Solution Size: No DC Blocking Capacitors Required on the RF Paths

Applications

- Cellular Handset Applications
- Cellular Infrastructure Applications

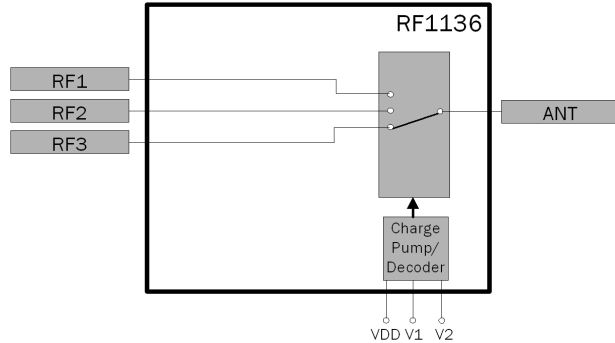

Functional Block Diagram

Product Description

The RF1136 is a single-pole three-throw (SP3T) switch designed for general purpose switching applications which require very low insertion loss and low power handling capability.

The RF1136 is ideally suited for battery operated applications requiring high performance switching with very low DC power consumption. The RF1136 features very low insertion loss with excellent linearity performance down to 1.8V control voltage. Additionally, RF1136 includes integrated decoding logic, allowing just two control lines needed for switch control. The RF1136 is packaged in a very compact 2.5mmx2.5mmx0.6mm, 12-pin, leadless QFN package.

Ordering Information

- RF1136 Broadband Low Power SP3T Switch
- RF1136PCBA-410 Fully Assembled Evaluation Board

Optimum Technology Matching® Applied

- | | | | |
|--------------------------------------|--------------------------------------|--|-----------------------------------|
| <input type="checkbox"/> GaAs HBT | <input type="checkbox"/> SiGe BiCMOS | <input checked="" type="checkbox"/> GaAs pHEMT | <input type="checkbox"/> GaN HEMT |
| <input type="checkbox"/> GaAs MESFET | <input type="checkbox"/> Si BiCMOS | <input checked="" type="checkbox"/> Si CMOS | <input type="checkbox"/> RF MEMS |
| <input type="checkbox"/> InGaP HBT | <input type="checkbox"/> SiGe HBT | <input type="checkbox"/> Si BJT | <input type="checkbox"/> LDMOS |

RF MICRO DEVICES®, RFMD®, Optimum Technology Matching®, Enabling Wireless Connectivity™, PowerStar®, POLARIS™ TOTAL RADIO™ and UltimateBlue™ are trademarks of RFMD, LLC. BLUETOOTH is a trademark owned by Bluetooth SIG, Inc., U.S.A. and licensed for use by RFMD. All other trade names, trademarks and registered trademarks are the property of their respective owners. ©2006, RF Micro Devices, Inc.

Absolute Maximum Ratings

Parameter	Rating	Unit
V _{DD} , V1, V2	6.0	V
Maximum Input Power (DC to 3.5GHz, 1.8V Control)	31	dBm
Operating Temperature	-30 to +85	°C
Storage Temperature	-65 to +100	°C



Caution! ESD sensitive device.

Exceeding any one or a combination of the Absolute Maximum Rating conditions may cause permanent damage to the device. Extended application of Absolute Maximum Rating conditions to the device may reduce device reliability. Specified typical performance or functional operation of the device under Absolute Maximum Rating conditions is not implied.

RoHS status based on EU Directive 2002/95/EC (at time of this document revision).

The information in this publication is believed to be accurate and reliable. However, no responsibility is assumed by RF Micro Devices, Inc. ("RFMD") for its use, nor for any infringement of patents, or other rights of third parties, resulting from its use. No license is granted by implication or otherwise under any patent or patent rights of RFMD. RFMD reserves the right to change component circuitry, recommended application circuitry and specifications at any time without prior notice.

Parameter	Specification			Unit	Condition
	Min.	Typ.	Max.		
					VDD=2.6V, V1, V2=High=1.8V, V1=V2=Low=0V. Temp=25°C.
Operating Frequency	600		3500	MHz	
Insertion Loss					
RFC-RF1, RF2, RF3		0.25	0.35	dB	RF ON, 50MHz to 450MHz
		0.25	0.40	dB	RF ON, 824MHz to 960MHz
		0.30	0.50	dB	RF ON, 1850MHz to 1990MHz
		0.40	0.55	dB	RF ON, 2170MHz to 2500MHz
		0.50	0.65	dB	RF ON, 3500MHz
Isolation					
RF1-RF2, RF3	27	29		dB	RF ON, 600MHz
	26	28		dB	RF ON, 824MHz to 960MHz
	20	22		dB	RF ON, 1850MHz to 1990MHz
	19	21		dB	RF ON, 2170MHz to 2500MHz
	16	18		dB	RF ON, 3500MHz
RFC-RF1, RF2, RF3	27	29		dB	RF ON, 600MHz
	26	28		dB	RF ON, 824MHz to 960MHz
	20	22		dB	RF ON, 1850MHz to 1990MHz
	19	21		dB	RF ON, 2170MHz to 2500MHz
RF Port Return Loss					
VSWR			1.5:1		
880MHz Harmonics					
Second Harmonic	75	90		dBc	P _{IN} = 16dBm; F ₀ = 880MHz
Third Harmonic	81	97		dBc	P _{IN} = 16dBm; F ₀ = 880MHz
1880MHz Harmonics					
Second Harmonic	85	96		dBc	P _{IN} = 16dBm; F ₀ = 1880MHz
Third Harmonic	79	93		dBc	P _{IN} = 16dBm; F ₀ = 1880MHz
2500MHz Harmonics					
Second Harmonic	85	96		dBc	P _{IN} = 16dBm; F ₀ = 2500MHz
Third Harmonic	79	93		dBc	P _{IN} = 16dBm; F ₀ = 2500MHz
IIP2					
RF1, RF2, RF3-ANT Cell	107	110		dBm	Tone 1: 836.5MHz at 16dBm, Tone 2: 1718MHz at -20dBm, Receive Freq: 881.5MHz
RF1, RF2, RF3-ANT AWS	108	110		dBm	Tone 1: 1732.5MHz at 16dBm, Tone 2: 3865MHz at -20dBm, Receive Freq: 2132.5MHz
RF1, RF2, RF3-ANT PCS	108	110		dBm	Tone 1: 1880MHz at 16dBm, Tone 2: 3840MHz at -20dBm, Receive Freq: 1960MHz

Parameter	Specification			Unit	Condition
	Min.	Typ.	Max.		
IIP3					
RF1, RF2, RF3-ANT Cell	62	64		dBm	Tone 1: 836.5 MHz at 16dBm, Tone 2: 791.5MHz at -20dBm, Receive Freq: 881.5MHz
RF1, RF2, RF3-ANT IMT	61	63		dBm	Tone 1: 1950MHz at 16 dBm, Tone 2: 1760MHz at -20dBm, Receive Freq: 2140MHz
Input Power at 0.1dB Compression Point					
	27			dBm	
Switching Speed					
		0.5	2	us	10% to 90% RFin, 90% to 10% RFin.
DC Supply					
VDD	2.50	2.6	3.30	V	
V1 and V2 (H)	1.30	1.80	2.90	V	
V1 and V2 (L)	0.00		0.40	V	
Supply Current		650	800	uA	
Control Current			40	uA	

Pin	Function	Description
1	VDD	Supply
2	V2	Control Signal 2
3	V1	Control Signal 1
4	GND	Ground
5	RF3	RF Output 3
6	GND	Ground
7	ANT	RF input. Connected to antenna.
8	GND	Ground
9	RF1	RF Output 1
10	GND	Ground
11	RF2	RF Output 2
12	GND	Ground
PKG BASE	GND	Ground

Pin Out

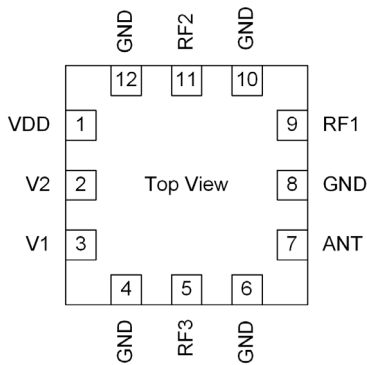

Package Drawing

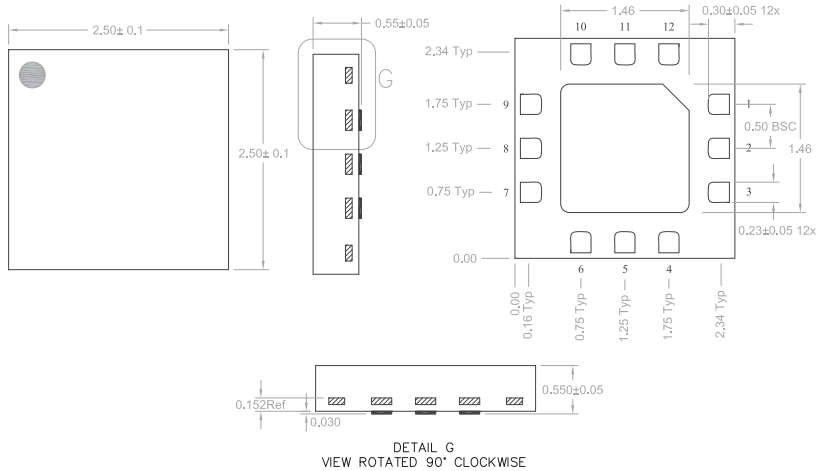

- 1) PIN 1 INDICATOR SHADED AREA
- 2) CHAMFERED AREA IS PIN 1 INDICATOR

General Information

Control Logic

The switch is operable in three states (see Truth table, below). The switch is designed for two modes: Active and Stand-by. These modes are controlled by the V_{DD} signal. When V_{DD} is high, the switch is active.

Control Logic

Mode	V1	V2	S1	S2	S3
ANT-RF1	High	Low	ON	OFF	OFF
ANT-RF2	Low	High	OFF	ON	OFF
ANT-RF3	Low	Low	OFF	OFF	ON

Electrical Test Methods

The electrical parameters for the switch were measured on test Evaluation Board provided by the switch supplier. The test Evaluation Board includes means for decoupling RF signals from control signal port (shunt capacitor at control signal ports).

All measurements are done with calibration plane at switch pins. The effect of test board losses and phase delay has been removed from the results.

Application Schematic

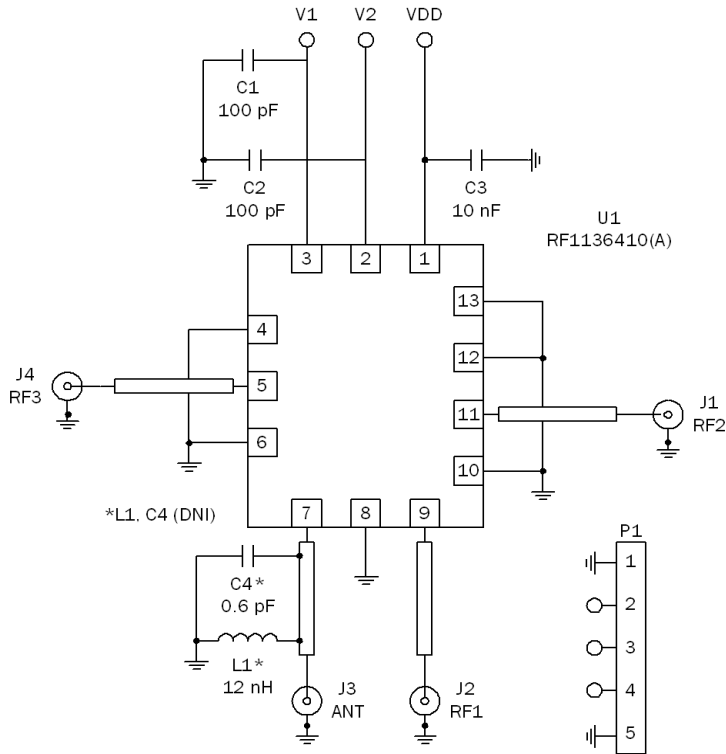

Application Diagram and Guidelines

The decoupling capacitors are optional and, if necessary, may be used for noise reduction. Decoupling capacitors on the control pins protect the control circuitry from possible RF leakage. DC Blocking capacitors are not needed on the RF paths as there is no DC on the RF paths, however care should be taken to ensure that DC is not injected into the switch from external circuitry. An ESD filter is needed to protect the switch from antenna ESD events. The filter is formed by LESD inductor and CESD capacitor. The switch has a supply input to feed the built-in logic decoding.

*LESD value will depend on the level of ESD protection and the loss acceptable in a given application.

Pin 13 is the package base and should be grounded as shown on the evaluation board for best performance.

Evaluation Board Layout

Board Thickness 0.0658", Board Material FR-4

Component Layer

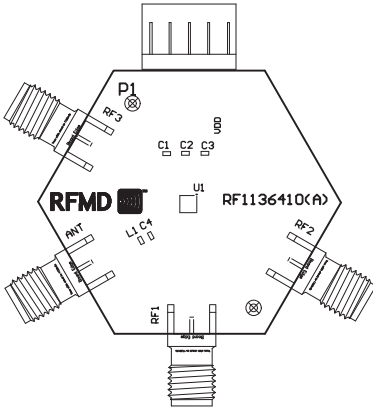

Topside RF Layer

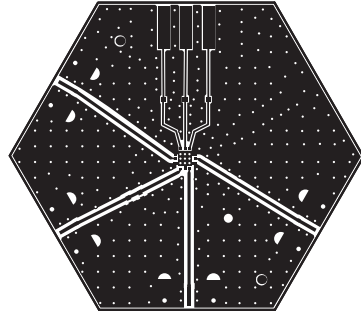

Typical Performance Data on Evaluation Board:

Fixture losses have been de-embedded (Temp=25 °C, VDD=2.6V, V1=V2=High=1.8V, V1=V2=Low=0V).

Insertion Loss

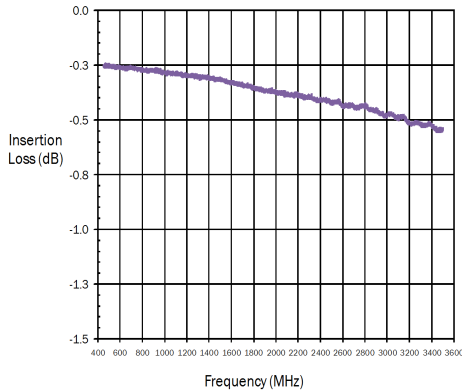

Output Power versus Input Power
(Frequency=1880MHz)

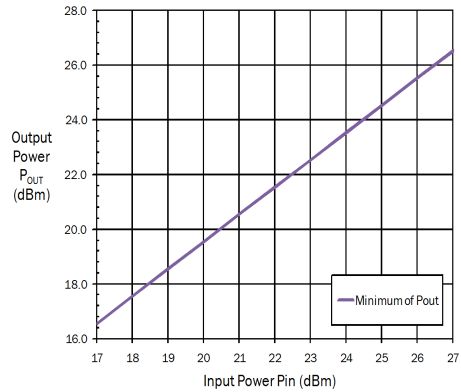

Output Power versus Input Power
(Frequency=1880MHz)

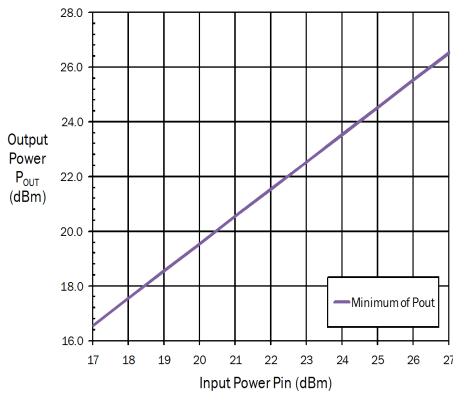

Harmonics
(Frequency=880MHz)

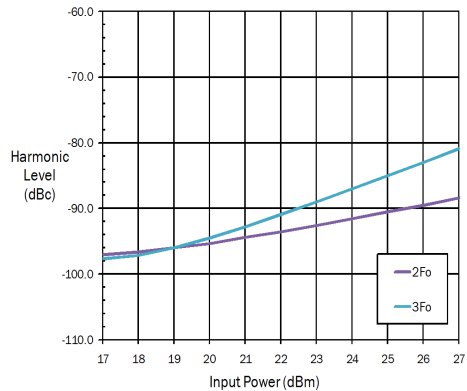

Output Power versus Input Power
(Frequency=1880MHz)

