



Features

- 450MHz to 2.69GHz Operation
- Very Low Insertion Loss:
Cell Band 0.40dB
PCS Band 0.55dB
- High Isolation:
Cell Band 30dB
PCS Band 22dB
- Compatible With Low Voltage Logic: ($V_{HIGH} = 1.8V$)
- Excellent Linearity Performance:
Cell Band 106dBm
PCS Band 108dBm
- Small Solution Size

Applications

- Cellular Handset Applications
- Cellular Infrastructure Applications

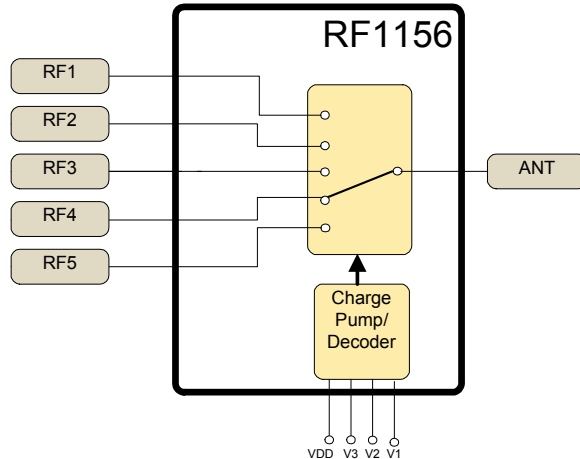

Functional Block Diagram

Product Description

The RF1156 is a single-pole five-throw (SP5T) switch designed for general purpose switching applications which require very low insertion loss and moderate power handling capability.

The RF1156 is ideally suited for battery operated applications requiring high performance switching with very low DC power consumption. The RF1156 features very low insertion loss with excellent linearity performance down to 1.8V control voltage. Additionally, RF1156 includes integrated decoding logic, allowing just three control lines needed for switch control. The RF1156 is packaged in a very compact 3mmx3mmx0.85mm, 16-pin, leadless QFN package. No DC-blocking capacitors are required on RF paths, unless DC is applied external to the device ports.

Ordering Information

RF1156	Broadband LOW Power SP5T Switch
RF1156PCBA-410	Fully Assembled Evaluation Board

Optimum Technology Matching® Applied

- | | | | |
|--------------------------------------|--------------------------------------|--|-----------------------------------|
| <input type="checkbox"/> GaAs HBT | <input type="checkbox"/> SiGe BiCMOS | <input checked="" type="checkbox"/> GaAs pHEMT | <input type="checkbox"/> GaN HEMT |
| <input type="checkbox"/> GaAs MESFET | <input type="checkbox"/> Si BiCMOS | <input checked="" type="checkbox"/> Si CMOS | <input type="checkbox"/> RF MEMS |
| <input type="checkbox"/> InGaP HBT | <input type="checkbox"/> SiGe HBT | <input type="checkbox"/> Si BJT | |

Absolute Maximum Ratings

Parameter	Rating	Unit
V _{DD} , V1, V2, V3	6.0	V
Maximum Input Peak Power Momentary Infrequent Occurrence	27 at 1:1 VSWR 24 at 6:1 VSWR	dBm
Maximum Continuous Power (PAR < 4)	23 at 1:1 VSWR 20 at 6:1 VSWR	dBm
Operating Temperature	-30 to +90	°C
Storage Temperature	-65 to +125	°C



Caution! ESD sensitive device.

Exceeding any one or a combination of the Absolute Maximum Rating conditions may cause permanent damage to the device. Extended application of Absolute Maximum Rating conditions to the device may reduce device reliability. Specified typical performance or functional operation of the device under Absolute Maximum Rating conditions is not implied.

RoHS status based on EU Directive 2002/95/EC (at time of this document revision).

The information in this publication is believed to be accurate and reliable. However, no responsibility is assumed by RF Micro Devices, Inc. ("RFMD") for its use, nor for any infringement of patents, or other rights of third parties, resulting from its use. No license is granted by implication or otherwise under any patent or patent rights of RFMD. RFMD reserves the right to change component circuitry, recommended application circuitry and specifications at any time without prior notice.

Parameter	Specification			Unit	Condition
	Min.	Typ.	Max.		
Operating Characteristics					Active Mode: V _{HIGH} ≥ 1.8V, V _{LOW} ≤ 0.4V; V _{DD} = 2.75V; Temp = 25 °C; P _{IN} = 16dBm unless otherwise specified.
Insertion Loss					
RF1-ANT, RF2-ANT, RF3-ANT, RF4-ANT, RF5-ANT		0.40	0.55	dB	450MHz to 960MHz
		0.45	0.60	dB	960 MHz to 1710 MHz
		0.55	0.75	dB	1710 MHz to 1990 MHz
		0.65	0.85	dB	1990 MHz to 2500 MHz
		0.65	0.95	dB	2500 MHz to 2690 MHz
Isolation					
RF1-ANT, RF2-ANT, RF3-ANT, RF4-ANT, RF5-ANT	26	30		dB	450MHz to 960MHz
	21	24		dB	960 MHz to 1710 MHz
	20	22		dB	1710 MHz to 1990 MHz
	19	21		dB	1990 MHz to 2500 MHz
	18	21		dB	2500 MHz to 2690 MHz
Return Loss					
RF1-ANT, RF2-ANT, RF3-ANT, RF4-ANT, RF5-ANT	18	20		dB	450MHz to 2690MHz, All RF ports in Insertion Loss state.s
Harmonics					
Second Harmonic (2F ₀)	70	83		dBc	F ₀ =880MHz
	70	84		dBc	F ₀ =1880MHz
Third Harmonic (3F ₀)	70	79		dBc	F ₀ =880MHz
	70	75		dBc	F ₀ =1880MHz
IIP2					
RF1-ANT, RF2-ANT, RF3-ANT, RF4-ANT, RF5-ANT (Cell)	103.5	106		dBm	Tone 1: 824MHz @ 16dBm, Tone 2: 1693MHz @ -20dBm, Receive Freq: 869MHz
RF1-ANT, RF2-ANT, RF3-ANT, RF4-ANT, RF5-ANT (AWS)	100	108		dBm	Tone 1: 1710MHz @ 16dBm, Tone 2: 3820MHz @ -20dBm, Receive Freq: 2110MHz
RF1-ANT, RF2-ANT, RF3-ANT, RF4-ANT, RF5-ANT (PCS)	100	108		dBm	Tone 1: 1850MHz @ 16dBm, Tone 2: 3780MHz @ -20dBm, Receive Freq: 1930MHz

Parameter	Specification			Unit	Condition
	Min.	Typ.	Max.		
IIP3					
RF1-ANT, RF2-ANT, RF3-ANT, RF4-ANT, RF5-ANT (Cell)	58	61		dBc	Tone 1: 836.5 MHz @ 16 dBm, Tone 2: 791.5 MHz @ -20 dBm Receive Freq: 881.5 MHz
RF1-ANT, RF2-ANT, RF3-ANT, RF4-ANT, RF5-ANT (IMT)	58	61		dBc	Tone 1: 1950 MHz @ 16 dBm, Tone 2: 1760 MHz @ -20 dBm Receive Freq: 2140 MHz
0.1dB Compression (P0.1dB)					
		29		dBm	f=900MHz
		28		dBm	f=1800MHz
Switching Speed					
		0.5	1.0	us	50% control to 10%/90%
Supply and Control Signal Characteristics					
Switch Supply Voltage (V _{DD})	2.50	2.75	3.30	V	Continuously
Control Voltage					
V _{HIGH}	1.3	1.8	2.9	V	
V _{LOW}	0		0.45	V	
Control Current		0.018	1.5	uA	P _{IN} = 16 dBm
Supply Current		0.6	0.9	mA	P _{IN} = 16 dBm

Pin	Function	Description
1	VDD	Supply.
2	V3	Control Signal V3.
3	V2	Control Signal V2.
4	V1	Control Signal V1.
5	GND	Ground.
6	RF4	RF Output 4.
7	GND	Ground.
8	RF3	RF Output 3.
9	RF5	RF Output 5.
10	GND	Ground.
11	ANT	RF input. Connected to antenna.
12	GND	Ground.
13	RF1	RF Output 1.
14	GND	Ground.
15	RF2	RF Output 2.
16	NC	Can be left floating or grounded.

Pin Out

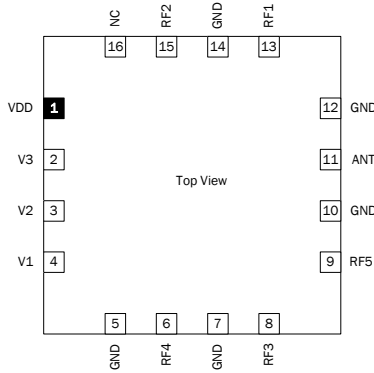

Package Drawing

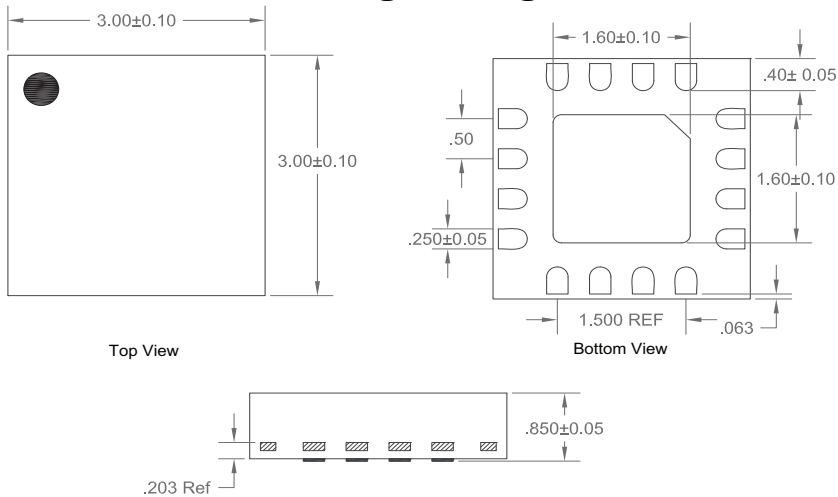

- Notes:
1) Pin 1 Shaded Area
2) Chamfered area Is Pin 1

General Information

Control Logic

The switch is operable in five states (see Truth table, below). The switch is designed for two modes: Active and Stand-by. These modes are controlled by the V_{DD} signal. When V_{DD} is high, the switch is active.

Control Logic

Mode	V1	V2	V3
ANT-RF1	Low	Low	Low
ANT-RF2	Low	Low	High
ANT-RF3	Low	High	Low
ANT-RF4	Low	High	High
ANT-RF5	High	Low	X

Electrical Test Methods

The electrical parameters for the switch were measured on test Evaluation Board provided by the switch supplier. The test Evaluation Board includes means for decoupling RF signals from control signal port (shunt capacitor at control signal ports).

All measurements are done with calibration plane at switch pins. The effect of test board losses and phase delay has been removed from the results.

Application Schematic

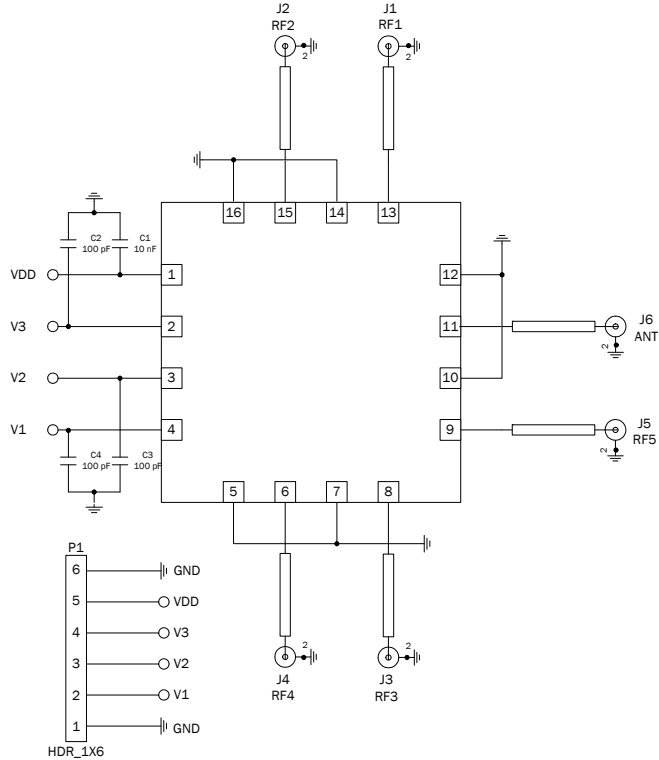

Application Diagram and Guidelines

The decoupling capacitors are optional and, if necessary, may be used for noise reduction. Decoupling capacitors on the control pins protect the control circuitry from possible RF leakage. DC Blocking capacitors are not needed on the RF paths as there is no DC on the RF paths, however care should be taken to ensure that DC is not injected into the switch from external circuitry. The switch has a supply input to feed the built-in logic decoding.

Evaluation Board Layout

Board Thickness 0.0658", Board Material FR-4 and Rogers R4003 8 mil top layer

Component Layer

Topside RF Layer

Inner Layer 1

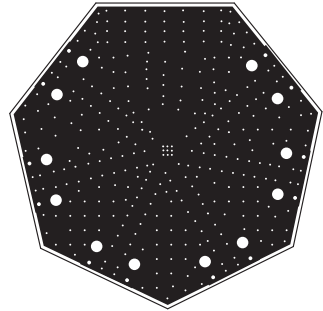
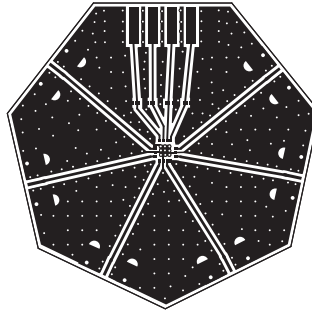
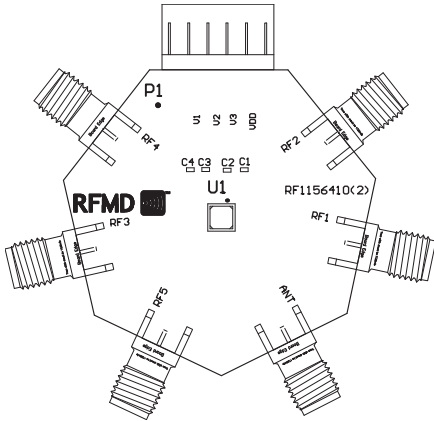

Inner Layer 2

Ground Plane Layer

