



### Features

- Integrated GSM RX SAW Filters for Ease of Implementation
- Very Low Insertion Loss
- Best in Class Harmonic Attenuation with Integrated LPF
- Exceptional Linearity Performance
- Lowest BOM Cost and Small Solution
- GPIO Interface and Compatible with 1.8V Logic (VCTL-High Min=1.3V)
- Compact Footprint, 4.5mmx4.5mmx1.2mm, 28-Pin Laminate module

### Applications

- Cellular Handset Applications
- Multi-Mode GSM, EDGE, WCDMA Applications
- Cellular modems and USB devices

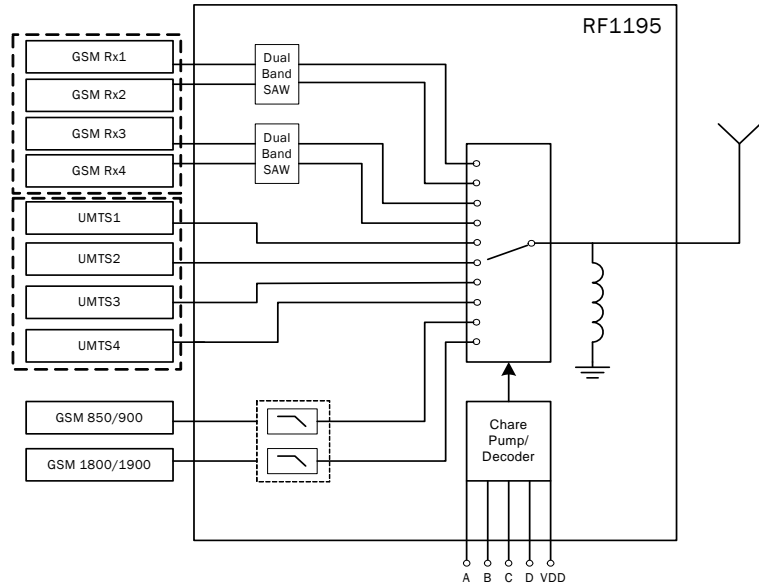

Functional Block Diagram

### Product Description

The RF1195 is a single-pole ten-throw (SP10T) Switch Filter Module. Low insertion loss along with excellent linearity performance achieved by the RF1195 makes it ideal for multi-mode GSM, EDGE, UMTS handset and data-card applications.

This module builds upon RFMD's pHEMT Switch technology and integrates low pass filtering on the GSM transmit paths thus avoiding the need for external harmonic attenuation. This module integrates Low loss GSM Receive SAW filters for ease of implementation. This module also integrates a decoder and is compatible with +1.8 V control logic. The RF1195 is packaged in a compact 4.5mmx4.5mmx1.2mm, 28-pin, laminate module which allows for a small solution size and lowest BOM cost as it does not require external DC blocking capacitors when external DC voltages are not applied to device ports.

### Ordering Information

RF1195	SP10T Switch Filter Module with Integrated GSM Receive Filters
RF1195PCBA-410	Fully Assembled Evaluation Board

### Optimum Technology Matching® Applied

- |                                      |                                      |  |                                   |
|--------------------------------------|--------------------------------------|--|-----------------------------------|
| <input type="checkbox"/> GaAs HBT    | <input type="checkbox"/> SiGe BiCMOS | <input checked="" type="checkbox"/> GaAs pHEMT | <input type="checkbox"/> GaN HEMT |
| <input type="checkbox"/> GaAs MESFET | <input type="checkbox"/> Si BiCMOS   | <input checked="" type="checkbox"/> Si CMOS    | <input type="checkbox"/> RF MEMS  |
| <input type="checkbox"/> InGaP HBT   | <input type="checkbox"/> SiGe HBT    | <input type="checkbox"/> Si BJT                | <input type="checkbox"/> LDMOS    |

RF MICRO DEVICES®, RFMD®, Optimum Technology Matching®, Enabling Wireless Connectivity™, PowerStar®, POLARIS™ TOTAL RADIO™ and UltimateBlue™ are trademarks of RFMD, LLC. BLUETOOTH is a trademark owned by Bluetooth SIG, Inc., U.S.A. and licensed for use by RFMD. All other trade names, trademarks and registered trademarks are the property of their respective owners. ©2006, RF Micro Devices, Inc.

## Absolute Maximum Ratings

Parameter	Rating	Unit
VDD, CTLA, CTLB, CTLC, CTLD	6.0	V
Maximum Input Power		
TX1 (GSM850/900), 50Ω	+37 (T <sub>AMB</sub> = 25 °C)	dBm
TX2 (GSM1800/1900), 50Ω	+36 (T <sub>AMB</sub> = 25 °C)	dBm
UMTS1, UMTS2, UMTS3, UMTS4	+32 (T <sub>AMB</sub> = 25 °C)	dBm
GSM RX Outputs	+13 (T <sub>AMB</sub> = 25 °C)	dBm
Operating Temperature	-30 to +85	°C
Storage Temperature	-65 to +150	°C



**Caution!** ESD sensitive device.

Exceeding any one or a combination of the Absolute Maximum Rating conditions may cause permanent damage to the device. Extended application of Absolute Maximum Rating conditions to the device may reduce device reliability. Specified typical performance or functional operation of the device under Absolute Maximum Rating conditions is not implied.

RoHS status based on EU Directive 2002/95/EC (at time of this document revision).

The information in this publication is believed to be accurate and reliable. However, no responsibility is assumed by RF Micro Devices, Inc. ("RFMD") for its use, nor for any infringement of patents, or other rights of third parties, resulting from its use. No license is granted by implication or otherwise under any patent or patent rights of RFMD. RFMD reserves the right to change component circuitry, recommended application circuitry and specifications at any time without prior notice.

Parameter	Specification			Unit	Condition
	Min.	Typ.	Max.		
					Nominal conditions unless otherwise stated. V <sub>DD</sub> = 2.7V, V <sub>HIGH</sub> /V <sub>LOW</sub> = 1.8V/0V, Temp = 25 °C
<b>GSM850/900 Transmit</b>					
Frequency Range (GSM850)	824	836.5	849	MHz	
Frequency Range (GSM900)	880.0	897.5	915.0	MHz	
Insertion Loss					
TX1 - ANT		1.20	1.5	dB	P <sub>IN</sub> = 35 dBm, 75% DC, 824 MHz to 849 MHz, 880 MHz to 915 MHz
Attenuation					
TX1 - ANT, 2fo	25	41		dB	P <sub>IN</sub> = 0 dBm
TX1 - ANT, 3fo	30	39		dB	P <sub>IN</sub> = 0 dBm
TX1 - ANT, 4fo - 7fo	21	28		dB	P <sub>IN</sub> = 0 dBm
TX1 - ANT, up to 12.75GHz	14	28		dB	P <sub>IN</sub> = 0 dBm
Isolation					
TX1 - GSM850 RX	35	57		dB	TX1 = 824 MHz to 849 MHz, 880 MHz to 915 MHz
TX1 - GSM900 RX	40	73		dB	TX1 = 824 MHz to 849 MHz, 880 MHz to 915 MHz
TX1 - GSM1800 RX	40	83		dB	TX1 = 824 MHz to 849 MHz, 880 MHz to 915 MHz
TX1 - GSM1900 RX	40	85		dB	TX1 = 824 MHz to 849 MHz, 880 MHz to 915 MHz
TX1 - TRX1	35	43		dB	TX1 = 824 MHz to 849 MHz, 880 MHz to 915 MHz
TX1 - TRX2	33	38		dB	TX1 = 824 MHz to 849 MHz, 880 MHz to 915 MHz
TX1 - TRX3	33	37		dB	TX1 = 824 MHz to 849 MHz, 880 MHz to 915 MHz
TX1 - TRX4	30	35		dB	TX1 = 824 MHz to 849 MHz, 880 MHz to 915 MHz
TX1 - TX2	20	23		dB	TX1 = 824 MHz to 849 MHz, 880 MHz to 915 MHz
TX2 - ANT	19	24		dB	TX1 = 1710 MHz to 1910 MHz

Parameter	Specification			Unit	Condition
	Min.	Typ.	Max.		
Harmonics					
TX1 - ANT, 2fo		-82	-70	dBc	P <sub>IN</sub> =35dBm, 75% DC
TX1 - ANT, 3fo		-75	-70	dBc	P <sub>IN</sub> =35dBm, 75% DC
TX1 - ANT, 4fo - 7fo		-96	-70	dBc	P <sub>IN</sub> =35dBm, 75% DC
TX1 - ANT, up to 12.75GHz		-112	-70	dBc	P <sub>IN</sub> =35dBm, 75% DC
VSWR			1.8		
<b>GSM850 Rx Mode</b>					
Frequency Range (GSM900)	869.0	881.5	894.0	MHz	
Passband Ripple		0.4	1.2	dB	
Balanced Output Impedance		150		Ω	
Phase	170	180	190	deg	
Amplitude Balance	-1		1	dB	
Insertion Loss		2.30	3.3	dB	
Attenuation					
0MHz to 824MHz	45	71		dB	ANT - RX
824MHz to 849MHz	45	58		dB	ANT - RX
915MHz to 960MHz	30	45		dB	ANT - RX
960MHz to 2000MHz	35	50		dB	ANT - RX
2000MHz to 6000MHz	28	40		dB	ANT - RX
Isolation GSM850 Rx to LBTX	50	65		dB	Tx1 - ANT, Freq=836.5MHz
VSWR (ANT & RX)			2.8		
<b>GSM900 Rx Mode</b>					
Frequency Range (GSM900)	925	942.5	960	MHz	
Passband Ripple		0.9	1.4	dB	
Balanced Output Impedance		150		Ohm	
Phase	170	180	190	deg	
Amplitude Balance	-1		1	dB	
Insertion Loss		2.50	3.40	dB	
Attenuation					
0MHz to 880MHz	45	75		dB	ANT - RX
880MHz to 905MHz	38	56		dB	ANT - RX
905MHz to 915MHz	27	35		dB	ANT - RX
980MHz to 1025MHz	30	47		dB	ANT - RX
1025MHz to 2000MHz	40	60		dB	ANT - RX
2000MHz to 6000MHz	30	46		dB	ANT - RX
Isolation GSM900 Rx to LBTX	50	77		dB	Tx1 - ANT, Freq=897.5MHz
VSWR (ANT & RX)			2.8		
<b>GSM1800/1900 Transmit</b>					
Frequency Range (GSM1800)	1710	1747.5	1785	MHz	
Frequency Range (GSM1900)	1850	1880	1910	MHz	
Insertion Loss					
TX2 - ANT		1.30	1.60	dB	P <sub>IN</sub> =33dBm, 75% DC, 1710MHz to 1785MHz, 1850MHz to 1910MHz

Parameter	Specification			Unit	Condition
	Min.	Typ.	Max.		
<b>GSM1800/1900 Transmit, cont.</b>					
Attenuation					
TX2 - ANT, 2fo	25	39		dB	$P_{IN}=0\text{dBm}$
TX2 - ANT, 3fo	25	35		dB	$P_{IN}=0\text{dBm}$
TX2 - ANT, 4fo	25	35		dB	$P_{IN}=0\text{dBm}$
TX2 - ANT, 5fo	25	37		dB	$P_{IN}=0\text{dBm}$
TX2 - ANT, 6fo	20	45		dB	$P_{IN}=0\text{dBm}$
Isolation					
TX2 - GSM850 RX	40	52		dB	TX2 = 1710MHz to 1785MHz, 1850MHz to 1910MHz
TX2 - GSM900 RX	40	55		dB	TX2 = 1710MHz to 1785MHz, 1850MHz to 1910MHz
TX2 - GSM1800 RX	35	52		dB	TX2 = 1710MHz to 1785MHz, 1850MHz to 1910MHz
TX2 - GSM1900 RX	40	73		dB	TX2 = 1710MHz to 1785MHz, 1850MHz to 1910MHz
TX2 - TRX1	30	34		dB	TX2 = 1710MHz to 1785MHz, 1850MHz to 1910MHz
TX2 - TRX2	26	28		dB	TX2 = 1710MHz to 1785MHz, 1850MHz to 1910MHz
TX2 - TRX3	27	29		dB	TX2 = 1710MHz to 1785MHz, 1850MHz to 1910MHz
TX2 - TRX4	23	26		dB	TX2 = 1710MHz to 1785MHz, 1850MHz to 1910MHz
TX2 - TX1	35	41		dB	TX2 = 1710MHz to 1785MHz, 1850MHz to 1910MHz
TX1 - ANT	25	34		dB	TX2 = 824MHz to 915MHz
Harmonics					
TX2 - ANT, 2fo		-81	-68	dBc	$P_{IN}=33\text{dBm}$ , 75% DC
TX2 - ANT, 3fo		-76	-68	dBc	$P_{IN}=33\text{dBm}$ , 75% DC
TX2 - ANT, up to 12.75GHz		-106	-68	dBc	$P_{IN}=33\text{dBm}$ , 75% DC
VSWR			1.7		
<b>GSM1800 Rx Mode</b>					
Frequency Range (GSM1800)	1805.0	1842.5	1880.0	MHz	
Passband Ripple		1.6	2.0	dB	
Balanced Output Impedance		150		$\Omega$	
Phase	168	180	192	deg	
Amplitude Balance	-1.5		1.5	dB	
Insertion Loss		3.15	4.21	dB	
Attenuation					
0MHz to 1580MHz	30	52		dB	ANT - RX
1580MHz to 1705MHz	30	45		dB	ANT - RX
1705MHz to 1785MHz	15	30		dB	ANT - RX
1920MHz to 1980MHz	20	26		dB	ANT - RX
1980MHz to 2500MHz	27	43		dB	ANT - RX
2500MHz to 3600MHz	30	40		dB	ANT - RX
3600MHz to 3840MHz	38	42		dB	ANT - RX
3840MHz to 6000MHz	38	48		dB	ANT - RX

Parameter	Specification			Unit	Condition
	Min.	Typ.	Max.		
<b>GSM1800 Rx Mode, cont.</b>					
Isolation GSM1800 Rx - HBTX	50	78		dB	Tx2 - ANT, Freq = 1747 MHz
VSWR (ANT & RX)			3.0		
<b>GSM1900 Rx Mode</b>					
Frequency Range (GSM1900)	1930	1960	1990	MHz	
Passband Ripple		0.9	1.6	dB	
Balanced Output Impedance		150		$\Omega$	
Phase	168	180	192	deg	
Amplitude Balance	-2		2	dB	
Insertion Loss		3.15	4.10	dB	
Attenuation					
0MHz to 1705MHz	27	49		dB	ANT - RX
1705MHz to 1785MHz	35	50		dB	ANT - RX
1830MHz to 1910MHz	12	29		dB	ANT - RX
2070MHz to 2150MHz	23	35		dB	ANT - RX
Isolation GSM1900 Rx - HBTX	50	60		dB	Tx2 - ANT, Freq = 1880 MHz
VSWR (ANT & RX)			3.0		
<b>UMTS 1, 2, 3, 4 - Low Band</b>					
Frequency Range	824		960	MHz	
Insertion Loss UMTS 1 - ANT		0.75	0.95	dB	
Insertion Loss UMTS 2 - ANT		0.75	0.95	dB	
Insertion Loss UMTS 3 - ANT		0.75	0.95	dB	
Insertion Loss UMTS4 - ANT		0.75	0.95	dB	
Isolation					
UMTS 1, 2, 3, 4 - GSM850 Rx	40	68		dB	
UMTS 1, 2, 3, 4 - GSM900 Rx	40	62		dB	
UMTS 1, 2, 3, 4 - GSM1800 Rx	60	77		dB	
UMTS 1, 2, 3, 4 - GSM1900 Rx	60	79		dB	
Harmonics					
UMTS 1, 2, 3, 4 - ANT, 2fo		-85	-62	dBc	$P_{IN}$ = 26dBm, CW
UMTS 1, 2, 3, 4 - ANT, 3fo		-85	-62	dBc	$P_{IN}$ = 26dBm, CW
UMTS 1, 2, 3, 4 - ANT, up to 12.75GHz		-96	-62	dBc	$P_{IN}$ = 26dBm, CW
IMD2					
TRX1 - ANT		-133	-115	dBm	Tone 1: 836.5MHz @ 20dBm, Tone 2: 45MHz @ -15dBm Receive Freq: 881.5MHz
TRX1 - ANT		-117	-114	dBm	Tone 1: 836.5MHz @ 20dBm, Tone 2: 1718MHz @ -15dBm Receive Freq: 881.5MHz
TRX2 - ANT		-133	-115	dBm	Tone 1: 836.5MHz @ 20dBm, Tone 2: 45MHz @ -15dBm Receive Freq: 881.5MHz
TRX2 - ANT		-116	-112	dBm	Tone 1: 836.5MHz @ 20dBm, Tone 2: 1718MHz @ -15dBm Receive Freq: 881.5MHz
TRX3 - ANT		-133	-115	dBm	Tone 1: 836.5MHz @ 20dBm, Tone 2: 45MHz @ -15dBm Receive Freq: 881.5MHz

Parameter	Specification			Unit	Condition
	Min.	Typ.	Max.		
<b>UMTS 1, 2, 3, 4 - Low Band, cont.</b>					
TRX3 - ANT		-116	-112	dBm	Tone 1: 836.5MHz @ 20dBm, Tone 2: 1718MHz @ -15dBm Receive Freq: 881.5MHz
TRX4 - ANT		-133	-113	dBm	Tone 1: 836.5MHz @ 20dBm, Tone 2: 45MHz @ -15dBm Receive Freq: 881.5MHz
TRX4 - ANT		-115	-112	dBm	Tone 1: 836.5MHz @ 20dBm, Tone 2: 1718MHz @ -15dBm Receive Freq: 881.5MHz
<b>IMD3</b>					
TRX1 - ANT		-118	-114	dBm	Tone 1: 836.5MHz @ 20dBm, Tone 2: 791.5MHz @ -15dBm Receive Freq: 881.5MHz
TRX1 - ANT		-116	-110	dBm	Tone 1: 836.5MHz @ 20dBm, Tone 2: 2554.5MHz @ -15dBm Receive Freq: 881.5MHz
TRX2 - ANT		-111	-109	dBm	Tone 1: 836.5MHz @ 20dBm, Tone 2: 791.5MHz @ -15dBm Receive Freq: 881.5MHz
TRX2 - ANT		-113	-109	dBm	Tone 1: 836.5MHz @ 20dBm, Tone 2: 2554.5MHz @ -15dBm Receive Freq: 881.5MHz
TRX3 - ANT		-111	-108	dBm	Tone 1: 836.5MHz @ 20dBm, Tone 2: 791.5MHz @ -15dBm Receive Freq: 881.5MHz
TRX3 - ANT		-114	-110	dBm	Tone 1: 836.5MHz @ 20dBm, Tone 2: 2554.5MHz @ -15dBm Receive Freq: 881.5MHz
TRX4 - ANT		-108	-104	dBm	Tone 1: 836.5MHz @ 20dBm, Tone 2: 791.5MHz @ -15dBm Receive Freq: 881.5MHz
TRX4 - ANT		-115	-111	dBm	Tone 1: 836.5MHz @ 20dBm, Tone 2: 2554.5MHz @ -15dBm Receive Freq: 881.5MHz
VSWR			1.6		
<b>UMTS 1, 2, 3 - High Band</b>					
Frequency Range	1710		1910	MHz	
	1910		2170	MHz	
Insertion Loss UMTS 1 - ANT		1.1	1.2	dB	P <sub>IN</sub> =26dBm, CW,1710MHz to 1910MHz
Insertion Loss UMTS 2 - ANT		0.95	1.2	dB	P <sub>IN</sub> =26dBm, CW,1710MHz to 1910MHz
Insertion Loss UMTS 3 - ANT		1.05	1.2	dB	P <sub>IN</sub> =26dBm, CW,1710MHz to 1910MHz
Insertion Loss UMTS 4 - ANT		1.05	1.2	dB	P <sub>IN</sub> =26dBm, CW,1710MHz to 1910MHz
Insertion Loss UMTS 1 - ANT		1.25	1.45	dB	P <sub>IN</sub> =26dBm, CW,1910MHz to 2170MHz
Insertion Loss UMTS 2 - ANT		1.05	1.4	dB	P <sub>IN</sub> =26dBm, CW,1910MHz to 2170MHz
Insertion Loss UMTS 3 - ANT		1.15	1.4	dB	P <sub>IN</sub> =26dBm, CW,1910MHz to 2170MHz
Insertion Loss UMTS 4 - ANT		1.15	1.3	dB	P <sub>IN</sub> =26dBm, CW,1910MHz to 2170MHz

Parameter	Specification			Unit	Condition
	Min.	Typ.	Max.		
<b>UMTS 1, 2, 3 - High Band, cont.</b>					
Isolation					
UMTS 1, 2, 3, 4 - GSM850 Rx	40	61		dB	
UMTS 1, 2, 3, 4 - GSM900 Rx	40	58		dB	
UMTS 1, 2, 3, 4 - GSM1800 Rx	28	50		dB	
UMTS 1, 2, 3, 4 - GSM1900 Rx	25	53		dB	
Harmonics					
UMTS 1 - ANT, 2fo		-63	-58	dBc	P <sub>IN</sub> = 26dBm, CW
UMTS 2, 3, 4 - ANT, 2fo		-68	-62	dBc	P <sub>IN</sub> = 26dBm, CW
UMTS 1, 2, 3, 4 - ANT, 3fo		-79	-62	dBc	P <sub>IN</sub> = 26dBm, CW
UMTS 1, 2, 3, 4 - ANT, up to 12.75GHz		-85	-62	dBc	P <sub>IN</sub> = 26dBm, CW
IMD2					
TRX1 - ANT		-117	-114	dBm	Tone 1: 1880MHz @ 20dBm, Tone 2: 80MHz @ -15dBm Receive Freq: 1960MHz
TRX1 - ANT		-112	-108	dBm	Tone 1: 1950MHz @ 20dBm, Tone 2: 190MHz @ -15dBm Receive Freq: 2140MHz
TRX2 - ANT		-119	-114	dBm	Tone 1: 1880MHz @ 20dBm, Tone 2: 80MHz @ -15dBm Receive Freq: 1960MHz
TRX2 - ANT		-104	-101	dBm	Tone 1: 1880MHz @ 20dBm, Tone 2: 3840MHz @ -15dBm Receive Freq: 1960MHz
TRX2 - ANT		-117	-111	dBm	Tone 1: 1950MHz @ 20dBm, Tone 2: 190MHz @ -15dBm Receive Freq: 2140MHz
TRX2 - ANT		-105	-102	dBm	Tone 1: 1950MHz @ 20dBm, Tone 2: 4090MHz @ -15dBm Receive Freq: 2140MHz
TRX3 - ANT		-120	-116	dBm	Tone 1: 1880MHz @ 20dBm, Tone 2: 80MHz @ -15dBm Receive Freq: 1960MHz
TRX3 - ANT		-109	-100	dBm	Tone 1: 1880MHz @ 20dBm, Tone 2: 3840MHz @ -15dBm Receive Freq: 1960MHz
TRX3 - ANT		-114	-110	dBm	Tone 1: 1950MHz @ 20dBm, Tone 2: 190MHz @ -15dBm Receive Freq: 2140MHz
TRX3 - ANT		-102	-100	dBm	Tone 1: 1950MHz @ 20dBm, Tone 2: 4090MHz @ -15dBm Receive Freq: 2140MHz

Parameter	Specification			Unit	Condition
	Min.	Typ.	Max.		
<b>UMTS 1, 2, 3 - High Band, cont.</b>					
IMD2, cont.					
TRX4 - ANT		-120	-116	dBm	Tone 1: 1880MHz @ 20dBm, Tone 2: 80MHz @ -15dBm Receive Freq: 1960MHz
TRX4 - ANT		-110	-106	dBm	Tone 1: 1880MHz @ 20dBm, Tone 2: 3840MHz @ -15dBm Receive Freq: 1960MHz
TRX4 - ANT		-117	-112	dBm	Tone 1: 1950MHz @ 20dBm, Tone 2: 190MHz @ -15dBm Receive Freq: 2140MHz
TRX4 - ANT		-107	-104	dBm	Tone 1: 1950MHz @ 20dBm, Tone 2: 4090MHz @ -15dBm Receive Freq: 2140MHz
IMD3					
TRX1 - ANT		-98	-94	dBm	Tone 1: 1880MHz @ 20dBm, Tone 2: 1800MHz @ -15dBm Receive Freq: 1960MHz
TRX1 - ANT		-114	-107	dBm	Tone 1: 1880MHz @ 20dBm, Tone 2: 5720MHz @ -15dBm Receive Freq: 1960MHz
TRX1 - ANT		-96	-92	dBm	Tone 1: 1950MHz @ 20dBm, Tone 2: 1760MHz @ -15dBm Receive Freq: 2140MHz
TRX1 - ANT		-111	-106	dBm	Tone 1: 1950MHz @ 20dBm, Tone 2: 6040MHz @ -15dBm Receive Freq: 2140MHz
TRX2 - ANT		-108	-104	dBm	Tone 1: 1880MHz @ 20dBm, Tone 2: 1800MHz @ -15dBm Receive Freq: 1960MHz
TRX2 - ANT		-120	-116	dBm	Tone 1: 1880MHz @ 20dBm, Tone 2: 5720MHz @ -15dBm Receive Freq: 1960MHz
TRX2 - ANT		-106	-102	dBm	Tone 1: 1950MHz @ 20dBm, Tone 2: 1760MHz @ -15dBm Receive Freq: 2140MHz
TRX2 - ANT		-124	-116	dBm	Tone 1: 1950MHz @ 20dBm, Tone 2: 6040MHz @ -15dBm Receive Freq: 2140MHz
TRX3 - ANT		-107	-103	dBm	Tone 1: 1880MHz @ 20dBm, Tone 2: 1800MHz @ -15dBm Receive Freq: 1960MHz
TRX3 - ANT		-122	-118	dBm	Tone 1: 1880MHz @ 20dBm, Tone 2: 5720MHz @ -15dBm Receive Freq: 1960MHz
TRX3 - ANT		-106	-102	dBm	Tone 1: 1950MHz @ 20dBm, Tone 2: 1760MHz @ -15dBm Receive Freq: 2140MHz
TRX3 - ANT		-125	-110	dBm	Tone 1: 1950MHz @ 20dBm, Tone 2: 6040MHz @ -15dBm Receive Freq: 2140MHz



Parameter	Specification			Unit	Condition
	Min.	Typ.	Max.		
<b>UMTS 1, 2, 3 - High Band, cont.</b>					
IMD3, cont.					
TRX4 - ANT		-108	-104	dBm	Tone 1: 1880MHz @ 20dBm, Tone 2: 1800MHz @ -15dBm Receive Freq: 1960MHz
TRX4 - ANT		-122	-118	dBm	Tone 1: 1880MHz @ 20dBm, Tone 2: 5720MHz @ -15dBm Receive Freq: 1960MHz
TRX4 - ANT		-110	-105	dBm	Tone 1: 1950MHz @ 20dBm, Tone 2: 17600MHz @ -15dBm Receive Freq: 2140MHz
TRX4 - ANT		-127	-113	dBm	Tone 1: 1950MHz @ 20dBm, Tone 2: 6040MHz @ -15dBm Receive Freq: 2140MHz
VSWR			1.6		
<b>DC Controls and Electrical Specifications</b>					
V <sub>DD</sub> - Switch Supply Voltage	2.5	2.7	3.3	V	
V <sub>DD</sub> Supply Current			1.1	mA	Active Mode
VC1, VC2, VC3, VC4 - Control Voltage - V <sub>HIGH</sub>	1.3	1.8	3.0	V	
VC1, VC2, VC3, VC4 - Control Voltage - V <sub>LOW</sub>		0	0.3	V	
Control Current			20	uA	
Switching Speed			5	uS	90% OFF to 90% ON, 90% ON to 90% OFF

Pin	Function	Description
1	GSM850RX	GSM850 Receive output.
2	GSM850RX	GSM850 Receive output.
3	GSM900RX	GSM900 Receive Output.
4	GSM900RX	GSM900 Receive Output.
5	GSM1800RX	GSM1800 Receive Output.
6	GSM1800RX	GSM1800 Receive Output.
7	GSM1900RX	GSM1900 Receive Output.
8	GSM1900RX	GSM1900 Receive Output.
9	GND	Ground.
10	VDD	Decoder and Charge Pump supply voltage (2.75 typical).
11	CTLD	RF Path Control D (See Switch Control table)-VC4
12	CTLC	RF Path Control C (See Switch Control table)-VC3
13	CTLB	RF Path Control B (See Switch Control table)-VC2
14	CTLA	RF Path Control A (See Switch Control table)-VC1
15	UMTS1	WCDMA RF Input/Output Port 1.
16	UMTS2	WCDMA RF Input/Output Port 2.
17	UMTS3	WCDMA RF Input/Output Port 3.
18	UMTS4	WCDMA RF Input/Output Port 4.
19	ANT	Connected to Antenna.
20	GND	Ground.
21	GND	Ground.
22	TX2	GSM1800/1900 RF Transmit Input.
23	GND	Ground.
24	GND	Ground.
25	TX1	GSM800/900 RF Transmit Input.
26	GND	Ground.
27	GND	Ground (Package Base).
28	GND	Ground (Package Base).

**Pin Out**

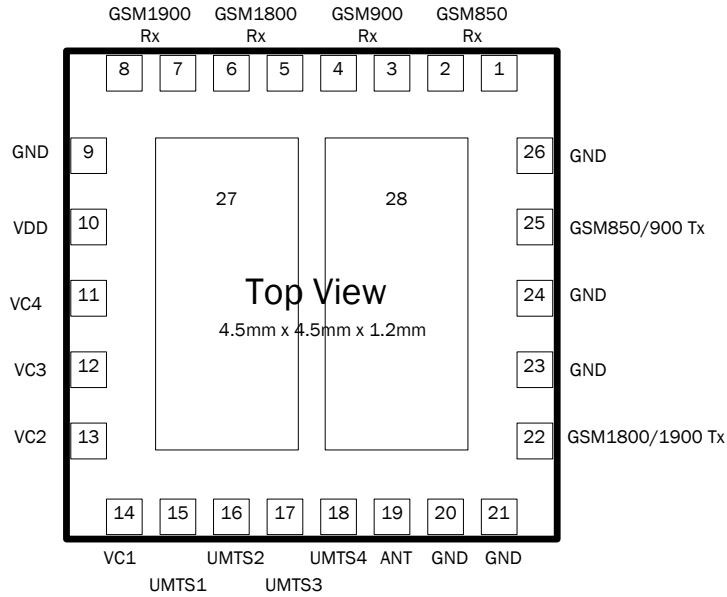

**Package Drawing**

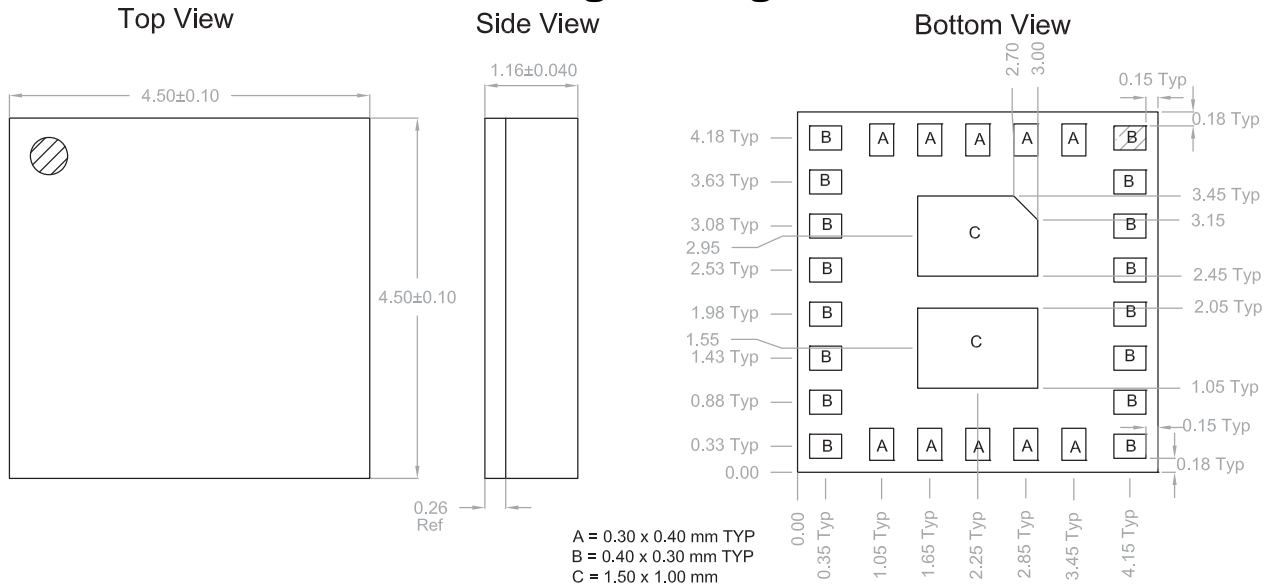

**Notes:**

1. Shaded area represents Pin 1 location
2. Defining I/O Pad Center:  
To define center of the I/O pad opening, draw a right triangle in one corner of the I/O pad  
Then take the center of the hypotenuse to determine center of I/O pad

## General Information

### Control Table

The SP10T switch is controlled by CTLA, CTLB, CTLC, and CTLD.

4 GSM+4 UMTS						
Mode	Switch Path	CTLA	CTLB	CTLC	CTLD	VDD
GSM Low Band Transmit	TX1-ANT	1	1	0	0	On
GSM High Band Transmit	TX2-ANT	1	0	0	0	On
GSM850 Receive	RX850-ANT	0	1	1	0	On
GSM900 Receive	RX900-ANT	0	1	0	0	On
GSM1800 Receive	RX1800-ANT	0	0	1	0	On
GSM1900 Receive	RX1900-ANT	0	0	0	0	On
UMTS/WCDMA 1	TRX1-ANT	1	0	1	0	On
UMTS/WCDMA 2	TRX2-ANT	1	0	1	1	On
UMTS/WCDMA 3	TRX3-ANT	1	1	1	0	On
UMTS/WCDMA 4	TRX4 - ANT	1	1	1	1	On
Idle	None	0	0	0	0	Off

**Application Schematic**

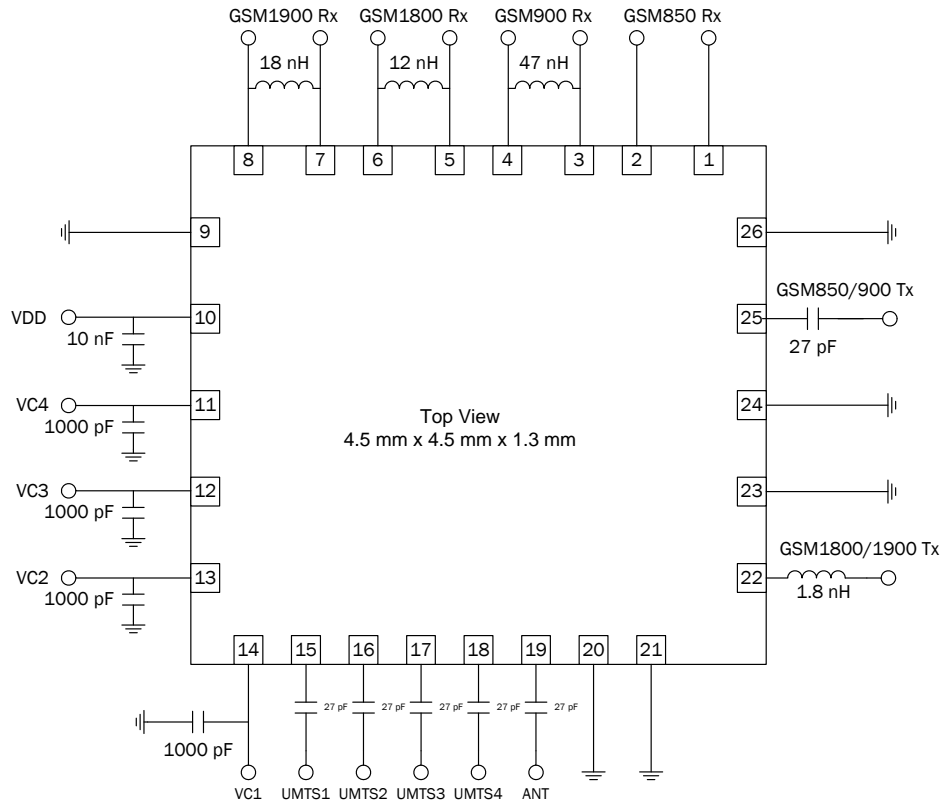

**Application Environment**

The switch can be placed directly under, or in close vicinity to, the antenna. Shielding cans covering the switch are not required, and they can be in close vicinity to the PA. The switch can be mounted on a flexible PWB.

**Application Diagram and Guidelines**

Decoupling capacitors on the control pins protect the control circuitry from possible RF leakage. 1nF decoupling capacitor is recommended on the V<sub>DD</sub> line.

**Electrical Test Methods**

The electrical parameters for the switch are measured on test PWB provided by RFMD. The test PWB includes means for decoupling RF signals from control signal port (shunt capacitor at control signal ports).

All measurements are done with calibration plane at switch pins. The effect of test board losses and phase delay are removed from the results by calibrating using the calibration board.

## Evaluation Board Schematic

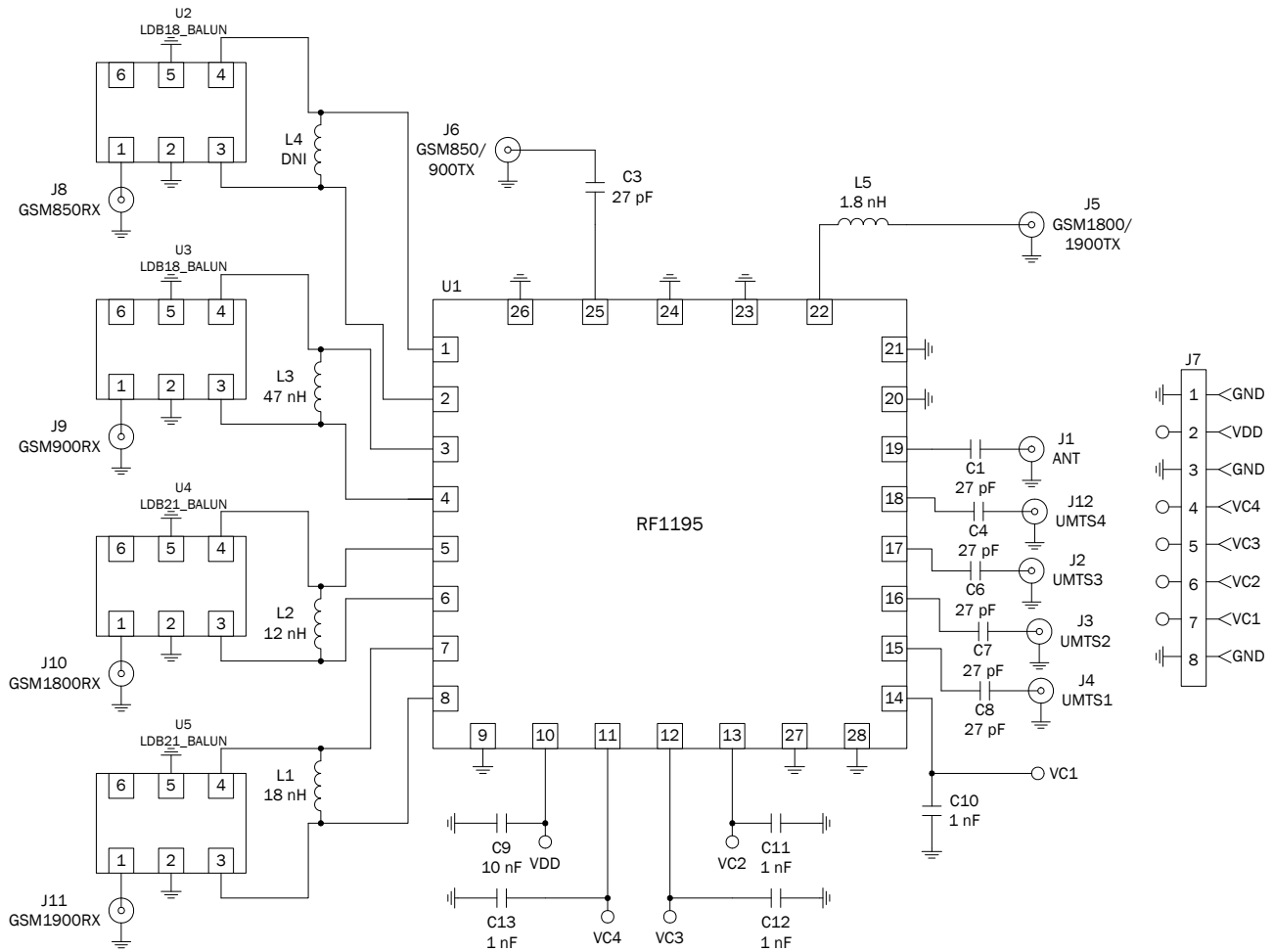

Note: Components U2, U3, U4 and U5 have been placed on the Evaluation Board to aid testing of GSM RX paths. These components may not be required in the actual application.

**Evaluation Board Layout**  
Board Thickness 0.32", Board Material FR-4 and R04003, Multi-Layer

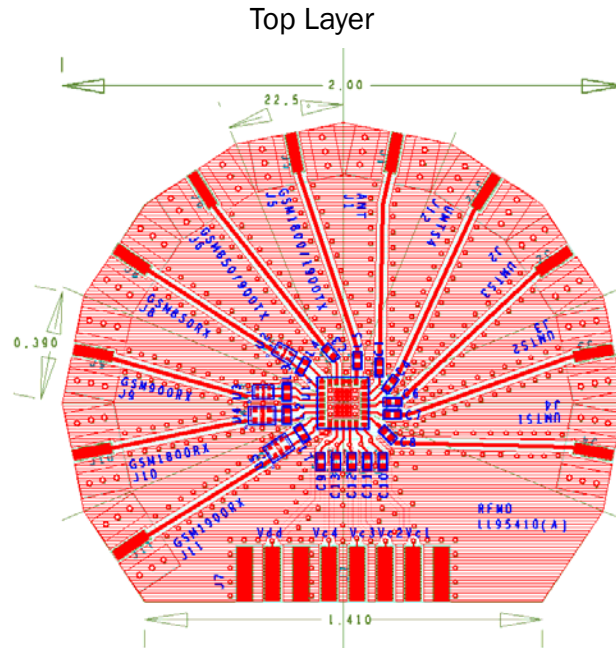

Top Layer (Medium Zoom)

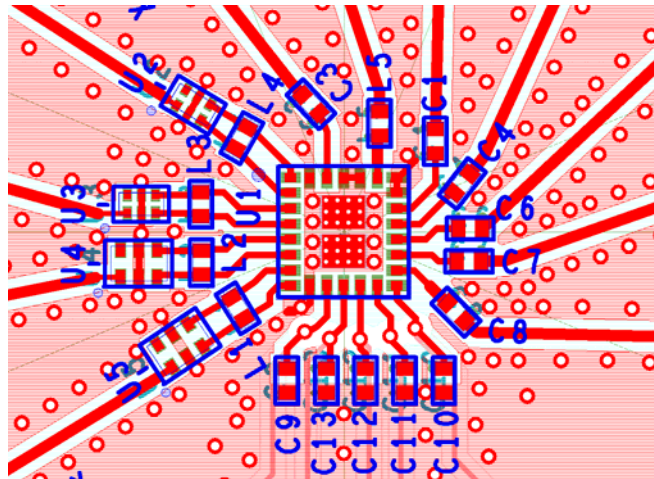

Top Layer (Full Zoom)

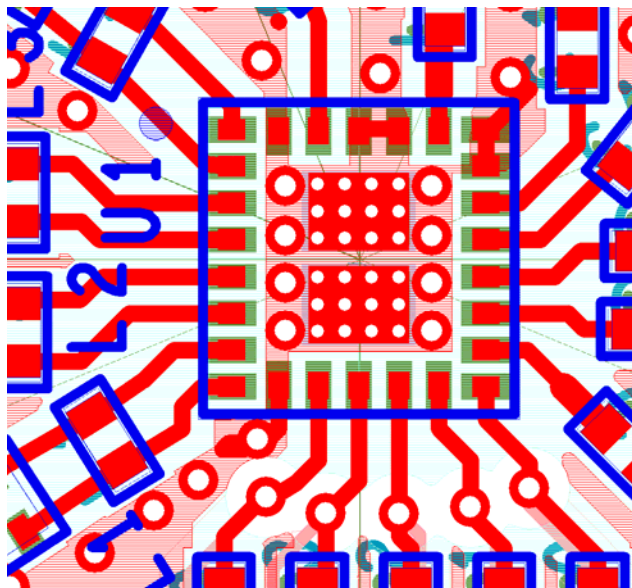

Finished Thickness with Plating: 0.32"  $\pm$  10%

Board Material: R04003 and FR-4

Layer Stack-up:

Layer 1 (Signal) 0.0017: 0.5oz Cu+Plating

Core: R04003 (0.008 $\pm$ 0.0015)

Layer 2 (Solid Plane) 0.0013: 1.0oz Cu

Core: FR-4 (0.008 $\pm$ 0.0015)

Layer 3 (Solid Plane) 0.0013" 1.0oz Cu

Core: FR-4 (0.008 $\pm$ 0.0015)

Layer 4 (Signal/Plane) 0.0017: 0.5 oz Cu+Plating



## Theory of Operation

### Product Description

The RF1195 is a SP10T Switch Filter Module (SFM) with fully integrated dual Low Pass Filters on GSM Transmit paths, integrated GSM Rx SAW filters, and an integrated decoder/charge-pump. This simplifies the phone design by eliminating the need for discrete filters, switches and the matching components. Integrated filtering provides ETSI compliant harmonic suppression at the antenna port even under mismatch conditions, which is important as modern antennas today often present a load that significantly deviates from nominal impedance.

This module also features an integrated charge-pump/decoder which allows for excellent linearity performance even at 1.8V control voltage. The decoder allows the switch to be controlled in any of the specified ten states as defined by the control logic on page 2 using 4 general-purpose I/O control lines.