

Package: QFN, 6-Pin, 2mmx2mmx0.85mm



Features

- Low Frequency - 2.5GHz Operation
- Low Insertion Loss: 0.3dB at 1GHz
- High Isolation: 26dB at 1GHz
- Low Control Voltage: 2.6V to 5.0V
- Operation at 1.8V Control for Low Power Applications
- Excellent Harmonic Performance: -80dBc at 1GHz
- GaAs pHEMT Process

Applications

- Cellular Handset Applications
- Antenna Tuning Applications
- Multi-Mode GSM, WCDMA Applications
- IEEE 802.11b/g WLAN Applications
- GSM/GPRS/EDGE Switch Applications
- Cellular Infrastructure Applications

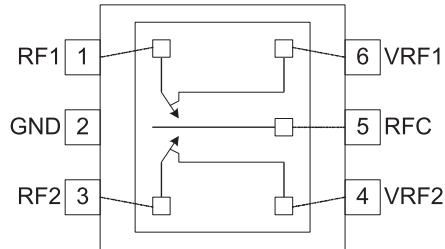

Functional Block Diagram

Product Description

The RF1200 is a single-pole double-throw (SPDT) switch designed for general purpose switching applications which require very low insertion loss and high power handling capability. The RF1200 is ideally suited for battery operated applications requiring high performance switching with very low DC power consumption. The RF1200 features low insertion loss, low control voltage, high linearity, and very good harmonic characteristics. It is fabricated with 0.5µm GaAs pHEMT process, and is packaged in a very compact 2mmx2mm, 6-pin, leadless QFN package.

Ordering Information

RF1200 Broadband High Power SPDT Switch
RF1200PCBA-410 Fully Assembled Evaluation Board

Optimum Technology Matching® Applied

- | | | | |
|--------------------------------------|--------------------------------------|--|------------------------------------|
| <input type="checkbox"/> GaAs HBT | <input type="checkbox"/> SiGe BiCMOS | <input checked="" type="checkbox"/> GaAs pHEMT | <input type="checkbox"/> GaN HEMT |
| <input type="checkbox"/> GaAs MESFET | <input type="checkbox"/> Si BiCMOS | <input type="checkbox"/> Si CMOS | <input type="checkbox"/> BiFET HBT |
| <input type="checkbox"/> InGaP HBT | <input type="checkbox"/> SiGe HBT | <input type="checkbox"/> Si BJT | <input type="checkbox"/> LDMOS |

RF MICRO DEVICES®, RFMD®, Optimum Technology Matching®, Enabling Wireless Connectivity™, PowerStar®, POLARIS™ TOTAL RADIO™ and UltimateBlue™ are trademarks of RFMD, LLC. BLUETOOTH is a trademark owned by Bluetooth SIG, Inc., U.S.A. and licensed for use by RFMD. All other trade names, trademarks and registered trademarks are the property of their respective owners. ©2006, RF Micro Devices, Inc.

Absolute Maximum Ratings

Parameter	Rating	Unit
V_{RF1}, V_{RF2}	7.0	V
Maximum Input Power		
0.88GHz (25°C, 50Ω)	+38	dBm
1.88GHz (25°C, 50Ω)	+35	dBm
Operating Temperature	-30 to +85	°C
Storage Temperature	-35 to +100	°C



Caution! ESD sensitive device.

Exceeding any one or a combination of the Absolute Maximum Rating conditions may cause permanent damage to the device. Extended application of Absolute Maximum Rating conditions to the device may reduce device reliability. Specified typical performance or functional operation of the device under Absolute Maximum Rating conditions is not implied.

RoHS status based on EUDirective2002/95/EC (at time of this document revision).

The information in this publication is believed to be accurate and reliable. However, no responsibility is assumed by RF Micro Devices, Inc. ("RFMD") for its use, nor for any infringement of patents, or other rights of third parties, resulting from its use. No license is granted by implication or otherwise under any patent or patent rights of RFMD. RFMD reserves the right to change component circuitry, recommended application circuitry and specifications at any time without prior notice.

Parameter	Specification			Unit	Condition
	Min.	Typ.	Max.		
					Temp = 25°C, $V_{CONTROL} = 2.65V$
Insertion Loss					
RF>ANT		0.3	0.4	dB	RF ON, 0.88GHz
RF>ANT		0.4	0.5	dB	RF ON, 1.88GHz
RF>ANT		0.5	0.6	dB	RF ON, 2.10GHz
RF>ANT		0.55	0.65	dB	RF ON, 2.45GHz
RF>ANT Isolation					
RF>ANT	26	27		dB	RF ON, 0.475GHz to 0.625GHz
RF>ANT	25	26		dB	RF ON, 0.88GHz
RF>ANT	21	22		dB	RF ON, 1.88GHz
RF>ANT	19	20		dB	RF ON, 2.10GHz
RF>ANT	17	18		dB	RF ON, 2.45GHz
0.475GHz to 0.625GHz Harmonics					
Second Harmonic		-114	-103	dBc	$P_{IN} = 10\text{ dBm}$, 0.475GHz to 0.625GHz, $2f_0$, $V_{CONTROL} = 4.5V$
Third Harmonic		-132	-105	dBc	$P_{IN} = 10\text{ dBm}$, 0.475GHz to 0.625GHz, $2f_0$, $V_{CONTROL} = 4.5V$
0.8GHz to 1GHz Harmonics					
Second Harmonic		-90	-78	dBc	$P_{IN} = 34.5\text{ dBm}$, 0.88GHz, $2f_0$
Third Harmonic		-85	-75	dBc	$P_{IN} = 34.5\text{ dBm}$, 0.88GHz, $3f_0$
1.7GHz to 2.0GHz Harmonics					
Second Harmonic		-80	-70	dBc	$P_{IN} = 31.5\text{ dBm}$, 1.9GHz, $2f_0$
Third Harmonic		-80	-70	dBc	$P_{IN} = 31.5\text{ dBm}$, 1.9GHz, $3f_0$
2.45GHz Harmonics					
Second Harmonic		-90	-70	dBc	$P_{IN} = 31.5\text{ dBm}$, 1.9GHz, $2f_0$
Third Harmonic		-90	-70	dBc	$P_{IN} = 31.5\text{ dBm}$, 1.9GHz, $3f_0$
IIP2					
RF1, RF2, RF3-ANT Cell	114	118		dBm	Tone 1: 836.5MHz at 26dBm, Tone 2: 1718MHz at -20dBm, Receive Freq: 881.5MHz
RF1, RF2, RF3-ANT AWS	113	117		dBm	Tone 1: 1732.5MHz at 26dBm, Tone 2: 3865MHz at -20dBm, Receive Freq: 2132.5MHz

Parameter	Specification			Unit	Condition
	Min.	Typ.	Max.		
RF1, RF2, RF3-ANT PCS	120	125		dBm	Tone 1: 1880MHz at 26dBm, Tone 2: 3840MHz at -20dBm, Receive Freq: 1960MHz
RF Port Return Loss					
RF>ANT		15		dB	0.5GHz to 2.5GHz
Input Power at 0.1dB Compression Point					
	37			dBm	0.88 GHz
	34			dBm	1.88 GHz
Switching Speed					
			5	μs	
Supply and Control Signal Characteristics					
Control Voltage					
V _{HIGH}		2.65	5.00	V	
V _{LOW}			0.2	V	
Control Current			20	μA	

Note: Parameters hold at 25°C and V_{CONTROL} = 2.65 V.

Switch Control Settings

	Control Signals		Signal Paths	
	VRF1	VRF2	RF1-RFC	RF2-RFC
Valid States	1	0	ON	OFF
	0	1	OFF	ON
Invalid States	0	0	Indeterminate State*	
	1	1	Indeterminate State*	

0: Logic level low, 0V~0.4V

1: Logic level high, 2.6V~5.0V

Note: In indeterminate states, both signal paths are ON with degraded performance.

Pin	Function	Description	Interface Schematic
1	RF1	First RF connection.	
2	GND	Ground.	
3	RF2	Second RF connection.	
4	VRF2	Second RF control.	
5	RFC	Common RF connection.	
6	VRF1	First RF control.	
Pkg Base	GND		

Package Drawing QFN, 6-pin, 2x2

NOTES:

1. SHADED PIN IS LEAD 1.
2. PIN 1 IDENTIFIER MUST EXIST ON TOP SURFACE OF PACKAGE BY IDENTIFICATION MARK OR FEATURE ON THE PACKAGE BODY. EXACT SHAPE AND SIZE IS OPTIONAL.

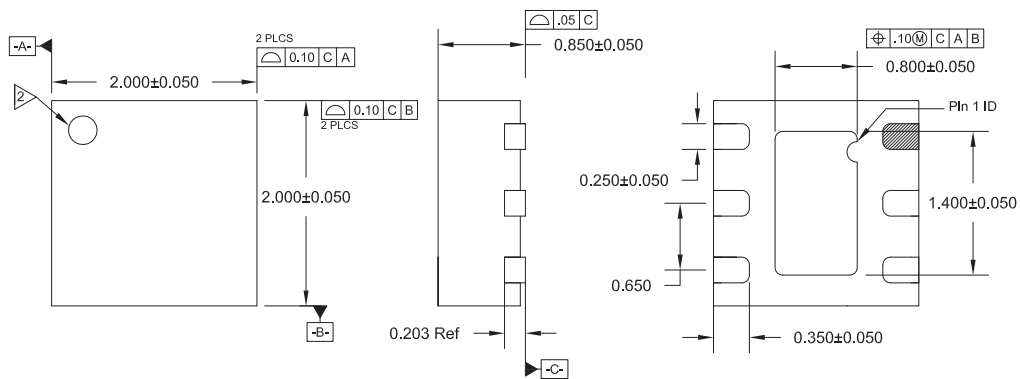

Prelim

Evaluation Board Schematic

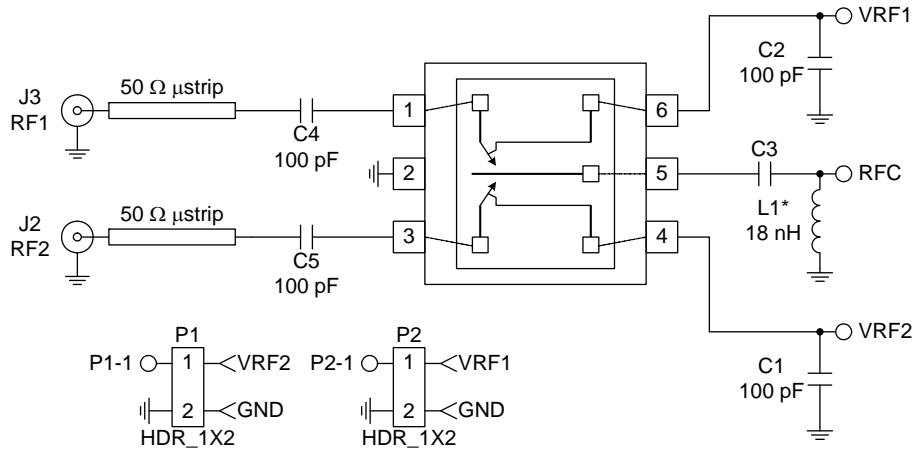

*L1 is optional for IEC61000-4-2 ESD protection.

PCB Design Requirements

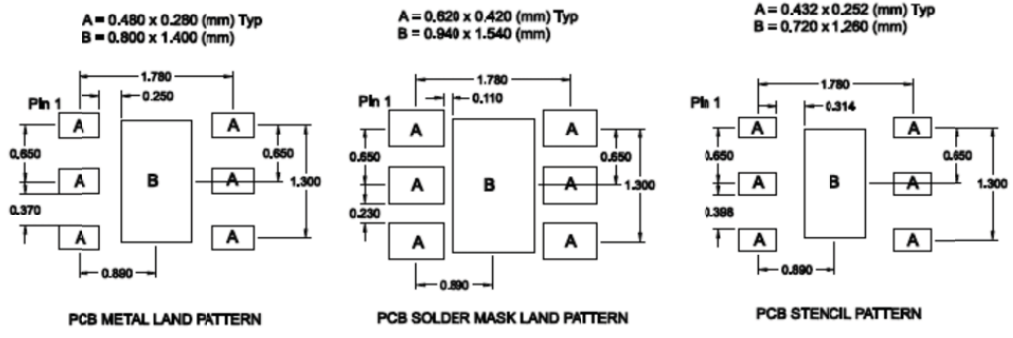

Typical Performance
Temp = 25 °C, V_{CONTROL} = 2.65V

