

RoHS Compliant & Pb-Free Product
Package Style: QFN, 20-pin, 3.5mmx3.5mm

Features

- Low Insertion Loss 0.4dB at 1GHz
- High Isolation 26dB at 1GHz
- Controlled by 3-Wire SPI Bus
- Compatible with 1.8V Logic: V_{CTL} High=1.3V to 2.7V
- V_{DD} = 1.5V to 3.0V
- AuxSPI V_{DD} = 1.5V to 3.0V
- High Linearity IMD3 <-108dBm, IMD2 <-103dBm
- Harmonics: -83dBcat 1GHz
- GaAs pHEMT Process

Applications

- Cellular Handset Applications
- Multi-Mode GSM, WCDMA Applications
- GSM/GPRS/EDGE Switch Applications
- Cellular Infrastructure Applications

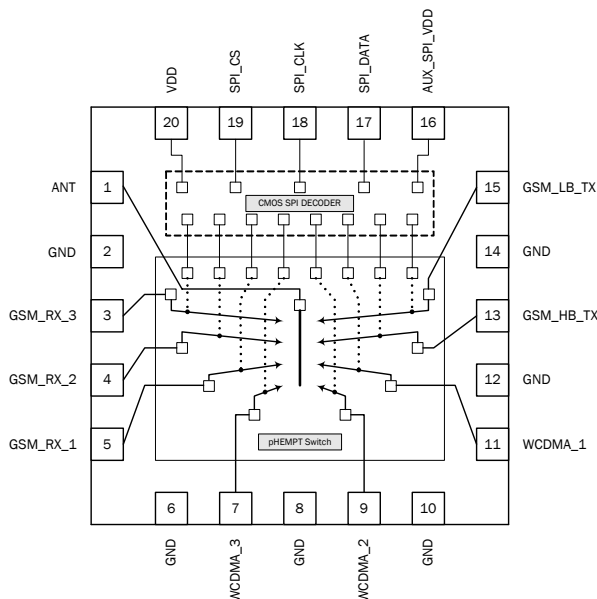

Functional Block Diagram

Product Description

The RF1480 is a single-pole eight-throw (SP8T) high power switch specially designed for GSM and WCDMA applications. Excellent linearity performance achieved by the RF1480 makes it ideal for multimode GSM/EDGE/WCDMA applications. Additionally, RF1480 includes integrated three wire SPI interface for switch control. The RF1480 is packaged in a very compact 3.5mmx3.5mmx0.85mm, 20-pin, leadless QFN package.

Ordering Information

RF1480 SP8T Switch
RF1480PCBA-410 Fully Assembled Evaluation Board

Optimum Technology Matching® Applied

- | | | | |
|--------------------------------------|--------------------------------------|--|-----------------------------------|
| <input type="checkbox"/> GaAs HBT | <input type="checkbox"/> SiGe BiCMOS | <input checked="" type="checkbox"/> GaAs pHEMT | <input type="checkbox"/> GaN HEMT |
| <input type="checkbox"/> GaAs MESFET | <input type="checkbox"/> Si BiCMOS | <input checked="" type="checkbox"/> Si CMOS | |
| <input type="checkbox"/> InGaP HBT | <input type="checkbox"/> SiGe HBT | <input type="checkbox"/> Si BJT | |

RF MICRO DEVICES®, RFMD®, Optimum Technology Matching®, Enabling Wireless Connectivity™, PowerStar®, POLARIS™ TOTAL RADIO™ and UltimateBlue™ are trademarks of RFMD, LLC. BLUETOOTH is a trademark owned by Bluetooth SIG, Inc., U.S.A. and licensed for use by RFMD. All other trade names, trademarks and registered trademarks are the property of their respective owners. ©2006, RF Micro Devices, Inc.

Absolute Maximum Ratings

Parameter	Rating	Unit
VDD	3.0	V
AUX_SPI_VDD	3.0	V
Maximum Input Power		
GSM_LB_TX	+36	dBm
GSM_HB_TX	+34	dBm
WCDMA 1, 2, 3	+26	dBm
Operating Temperature	-30 to +85	°C
Storage Temperature	-55 to +125	°C



Caution! ESD sensitive device.

Exceeding any one or a combination of the Absolute Maximum Rating conditions may cause permanent damage to the device. Extended application of Absolute Maximum Rating conditions to the device may reduce device reliability. Specified typical performance or functional operation of the device under Absolute Maximum Rating conditions is not implied.

RoHS status based on EU Directive 2002/95/EC (at time of this document revision).

The information in this publication is believed to be accurate and reliable. However, no responsibility is assumed by RF Micro Devices, Inc. ("RFMD") for its use, nor for any infringement of patents, or other rights of third parties, resulting from its use. No license is granted by implication or otherwise under any patent or patent rights of RFMD. RFMD reserves the right to change component circuitry, recommended application circuitry and specifications at any time without prior notice.

Parameter	Specification			Unit	Condition
	Min.	Typ.	Max.		
					Nominal Conditions. Unless otherwise specified. $V_{DD}=2.7V$, AuxSPI $V_{DD}=1.8V$, Temp=25°C
Insertion Loss					
WCDMA 1, 2, 3 to ANT					
1920MHz to 2170MHz		0.75	0.90	dB	GTC3 25.5dBm
1710MHz to 1990MHz		0.70	0.85	dB	GTC3 25.5dBm
824MHz to 960MHz		0.55	0.65	dB	GTC3 25.5dBm
GSM_HB to ANT					
1710MHz to 1910MHz		0.70	0.80	dB	33dBm
GSM_LB to ANT					
824MHz to 915MHz		0.55	0.60	dB	35dBm
GSM_RX 1, 2, 3 to ANT					
869MHz to 960MHz		0.85	0.95	dB	-15dBm
1805MHz to 1990MHz		1.25	1.45	dB	-15dBm
Return Loss					
ANT to Any Port					
824MHz to 2170MHz	11	23		dB	-15dBm
WCDMA 1, 2, 3 to ANT					
824MHz to 2170MHz	17	25		dB	25.5dBm
GSM_HB_TX to ANT					
1710MHz to 1910MHz	20	27		dB	33dBm
GSM_LB_TX to ANT					
824MHz to 915MHz	19	22		dB	35dBm
ANT to Any GSM_RX					
869MHz to 1990MHz	11	20		dB	-15dBm
Forward Isolation					
GSM_HB_TX to ANT					
1710MHz to 1910MHz	26	27		dB	33dBm
GSM_LB_TX to ANT					
824MHz to 915MHz	23	27		dB	35dBm

Parameter	Specification			Unit	Condition
	Min.	Typ.	Max.		
Pin to Pin Isolation					
WCDMA 1, 2, 3 to Any RX Port (GSM and W-CDMA)					
1710MHz to 1980MHz	26	27		dB	25.5dBm
GSM_HB_TX to Any RX Port (GSM)					
1710MHz to 1910MHz	35	38		dB	33dBm
GSM_HB_TX to any RX Port (W-CDMA 1, 2, 3)					
1710MHz to 1910MHz	26	27		dB	33dBm
GSM_LB_TX to Any RX Port (GSM)					
824 MHz to 915 MHz	41	44		dB	35dBm
GSM_LB_TX to any RX Port (W-CDMA 1, 2, 3)					
824 MHz to 915 MHz	28	29		dB	35dBm
Operating Characteristics					
IIP2	110	113		dBm	WCDMA_1, 2, 3 to Ant
IIP3	64	67		dBm	
Second Harmonic ($2f_0$)					
900MHz		-83		dBc	GSM_LB_TX
1800MHz		-83		dBc	GSM_HB_TX
824 MHz to 1980 MHz		-89		dBc	WCDMA_1, 2, 3
Third Harmonic ($3f_0$)					
900MHz		-83		dBc	GSM_LB_TX
1800MHz		-83		dBc	GSM_HB_TX
824 MHz to 1980 MHz		-89		dBc	WCDMA_1, 2, 3
IMD3					
$F_{TX}=1950\text{MHz}$ $F_{INT}=1760$		-111.0	-104.5	dBm	TX power level = +20dBm, 50Ω
IMD2					
$F_{TX}=1950\text{MHz}$ $F_{INT}=190$		-107	-104	dBm	Interferer = -15dBm, 50Ω WCDMA_1, 2, 3 to Ant
Spectrum Emissions					
824MHz to 1980 MHz TX			-83	dBc	WCDMA_1, 2, 3 to Ant 25.5 dBm, 75% duty cycle
1710MHz to 19180 MHz TX			-83	dBc	GSM_HB_TX to Ant 33 dBm, 75% duty cycle
824 MHz to 915 MHz TX			-83	dBc	GSM_LB_TX to Ant 35 dBm, 75% duty cycle
869MHz to 1990 MHz RX			-132.5	dBm	Ant to any GSM_RX RBW = 180kHz
869MHz to 2170 MHz RX			-114	dBm	Ant to WCDMA_1, 2, 3 RBW = 3.84 MHz

Parameter	Specification			Unit	Condition
	Min.	Typ.	Max.		
Operating Characteristics (continued)					
Power Handling in Mismatched Condition					
900MHz		35		dBm	VSWR > 20:1
1800MHz		33		dBm	VSWR > 20:1
Switching Speed		0.5	2	μs	
Start-up Time		7	10	μs	Time for the switch to be operational from the time that the switched supply voltage (V _{DD}) goes high.
Supply and Control Signal Characteristics					
Switch Supply Voltage (V _{DD})	2.5	2.7	3.0	V	Continuously
Switch Supply Current (V _{DD})		500	850	μA	Active Mode DC DC Converter on
		400	650	μA	Active Mode DC DC Converter off
		20	30	μA	Standby Mode (Switch disabled)
SPI Supply Voltage (AuxSpiV _{DD})	1.5	1.8	3.0	V	SPI Controller enabled
		0	0.3	V	Standby Mode (Switch disabled)
SPI Supply Current (AuxSpiI _{DD})		250	400	μA	During SPI read
SPI Controller Enable			150	μs	
SPI Control Voltage					
V _{HIGH}		1.8		V	SPI_EN, SPI_CLK
V _{LOW}		0		V	SPI_DATA

*Through phase is defined as measured normalized using a reference calibration PWB.

Pin	Function	Description
1	ANT	RF Input (connected to antenna).
2	GND	Ground.
3	GSM_RX_3	GSM RF Output 3.
4	GSM_RX_2	GSM RF Output 2.
5	GSM_RX_1	GSM RF Output 1.
6	GND	Ground.
7	WCDMA_3	WCDMA RF Input/Output 3.
8	GND	Ground.
9	WCDMA_2	WCDMA RF Input/Output 2.
10	GND	Ground.
11	WCDMA_1	WCDMA RF Input/Output 1.
12	GND	Ground.
13	GSM_LB_TX	GSM RF Input (High Band).
14	GND	Ground.
15	GSM_HB_TX	GSM RF Input (Low Band).
16	AUX_SPI_VDD	SPI Supply Voltage.
17	SPI_DATA	SPI Data Input.
18	SPI_CLK	SPI Clock Input.
19	SPI_CS	SPI Chip select.
20	VDD	Supply. The voltage at this node will be switched on before AUX_SPI_VDD is powered up.
Pkg Base	GND	

Pin Out

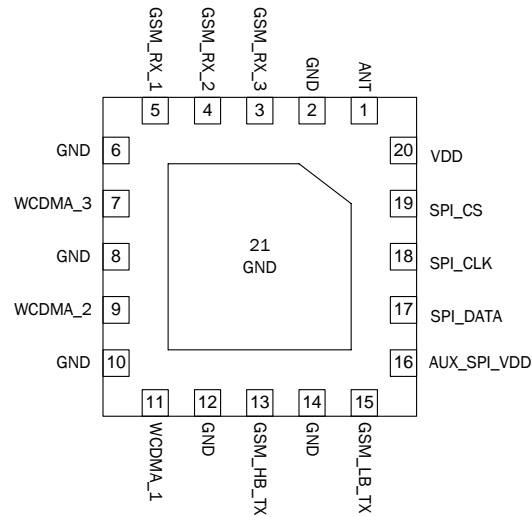

Top View
(Through Package)

Package Drawing

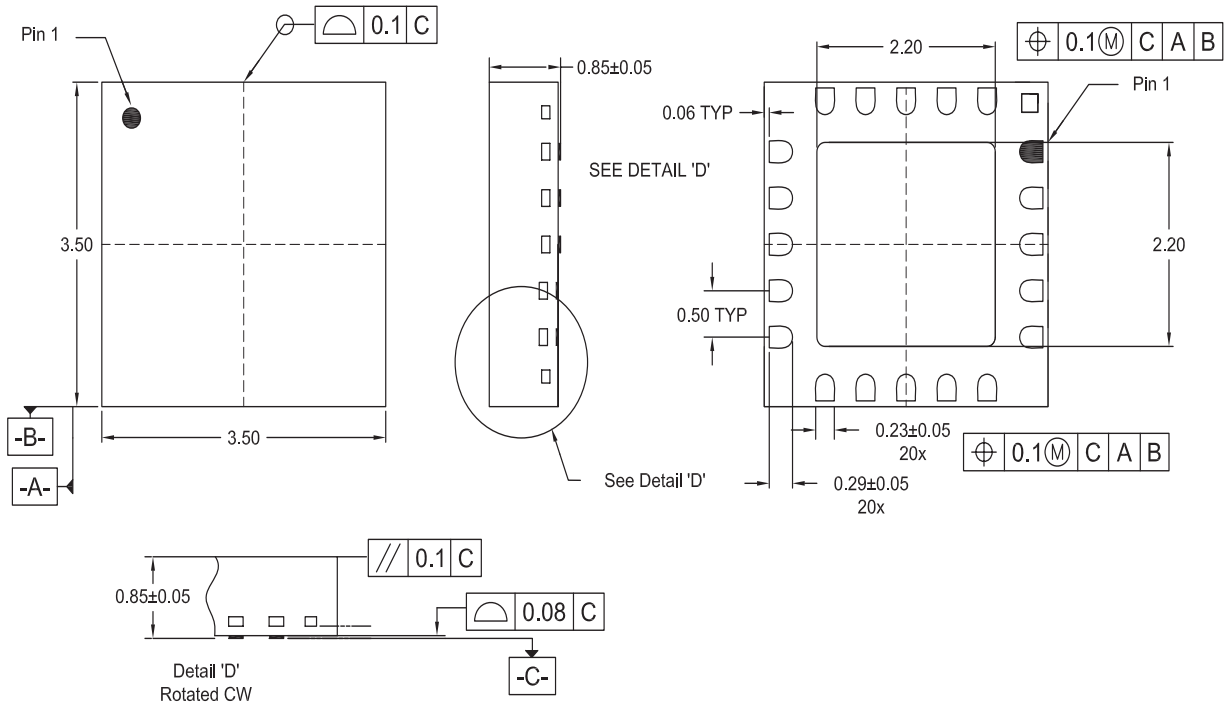

General Information

Data Write

The SP8T switch is controlled by a 30-bit 3-wire SPI bus.

This section describes how the SP8T is programmed through the 30-bit 3-wire SPI bus.

Bit	Function	Set	Description
29	Read/Write Mode	1	Not used for front end switch
		0	Write to the switch
28	Address (Slave Type)	0	001 used for front end switches
27		0	
26		1	
25	Address (Slave Identifier)	0	This is a non-volatile value programmed by the vendor. 0000=FE switch module for single antenna radios or for TX path FE switch module in multi-antenna radios. 00001=Diversity front end switch (not used on this "main" switch)
24		0	
23		0	
22		0	
21		0	
20	Address (Slave SPI Register)	0	Only one SPI register will be used on the front end switch
19		0	
18		0	
17		0	
16		0	
15	DCDC Converter Enable	1/0	A logic high enables the DCDC converter (if applicable).
14 13 12 11	FE Select 4=MSB FE Select 3 FE Select 2 FE Select 1=LSB	0000	Switch disabled (low current mode)
		0001	GSM_HB_TX enable
		0010	GSM_LB_TX enable
		0011	Not used/reserved
		0100	GSM_RX_1 enable
		0101	GSM_RX_2 enable
		0110	GSM_RX_3 enable
		0111	Not used/reserved
		1000	WCDMA_1 enable
		1001	WCDMA_2 enable
1010	WCDMA_3 enable		
1011	Not used/reserved		
10	Not Used	X	Not used/reserved
9	Not Used	X	Not used/reserved
8	Not Used	X	Not used/reserved
7	Not Used	X	Not used/reserved
6	Not Used	X	Not used/reserved
5	Not Used	X	Not used/reserved
4	Not Used	X	Not used/reserved
3	Not Used	X	Not used/reserved
2	Not Used	X	Not used/reserved
1	Not Used	X	Not used/reserved
0	Not Used	X	Not used/reserved

Global Command Write

A global command is when bits 28-21 are all sent with high logic level. In this mode, bits 20-16 are used to issue the command, and bits 15-0 are ignored. If bits 20-16 are all sent with high logic level, the switch will go into standby mode until a SPI command is issued to enable it. If bits 28-16 are not all “1”, the command is ignored.

Bit	Function	Set	Description
29	Read/Write Mode	0	Logic low command puts device in read mode
28	Address (Slave Type)	1	111 used for global write
27		1	
26		1	
25	Address (Slave Identifier)	1	11111 used for global write
24		1	
23		1	
22		1	
21		1	
20	Command	1/0	A transmission of “11111” must put the switch into standby mode.
19		1/0	
18		1/0	
17		1/0	
16		1/0	
15	Not Used	X	Data bit must be ignored during Global Command Write
14	Not Used	X	Data bit must be ignored during Global Command Write
13	Not Used	X	Data bit must be ignored during Global Command Write
12	Not Used	X	Data bit must be ignored during Global Command Write
11	Not Used	X	Data bit must be ignored during Global Command Write
10	Not Used	X	Data bit must be ignored during Global Command Write
9	Not Used	X	Data bit must be ignored during Global Command Write
8	Not Used	X	Data bit must be ignored during Global Command Write
7	Not Used	X	Data bit must be ignored during Global Command Write
6	Not Used	X	Data bit must be ignored during Global Command Write
5	Not Used	X	Data bit must be ignored during Global Command Write
4	Not Used	X	Data bit must be ignored during Global Command Write
3	Not Used	X	Data bit must be ignored during Global Command Write
2	Not Used	X	Data bit must be ignored during Global Command Write
1	Not Used	X	Data bit must be ignored during Global Command Write
0	Not Used	X	Data bit must be ignored during Global Command Write

Electrical Test Methods

The electrical parameters for the switch are measured on test PWB provided by RFMD. The test PWB includes means for decoupling RF signals from control signal port (shunt capacitor at control signal ports).

All measurements are done with calibration plane at switch pins. The effect of test board losses and phase delay are removed from the results by calibrating using the calibration board.

Application Schematic

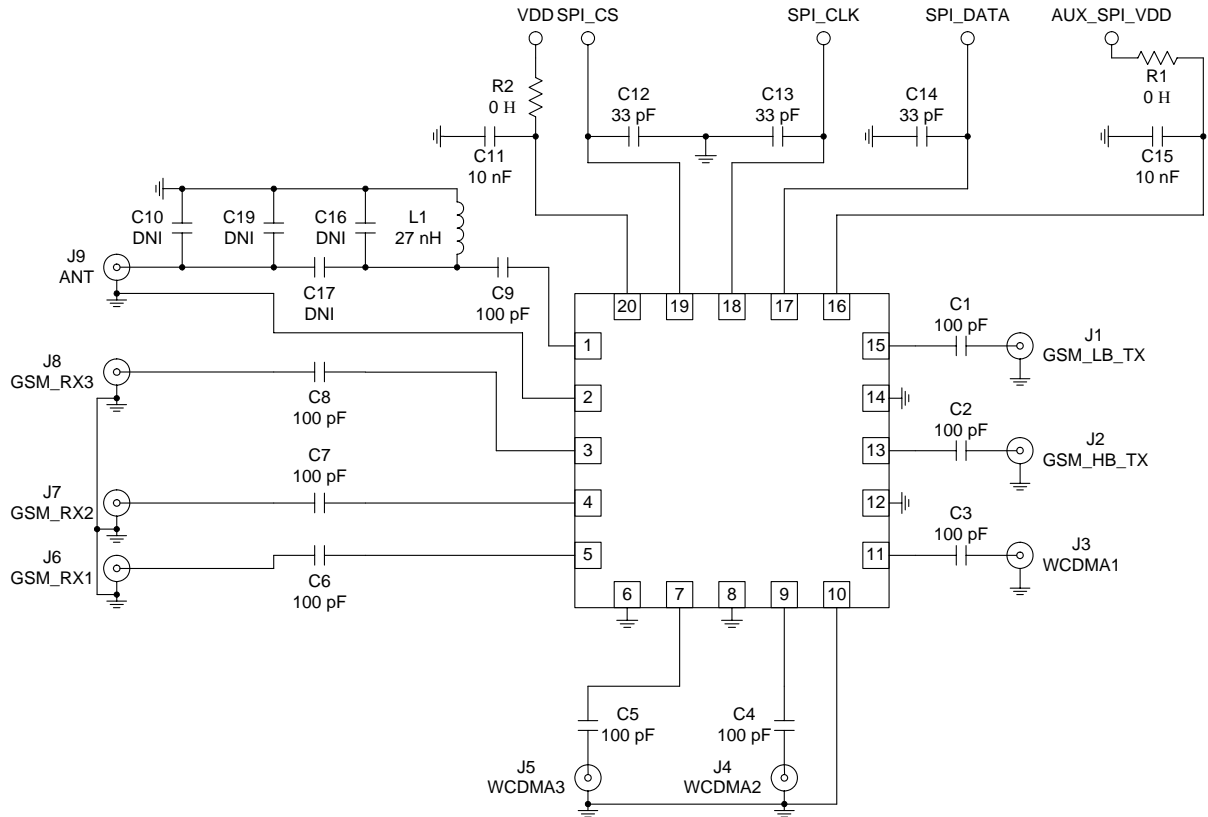

Application Environment

The switch can be placed directly under, or in close vicinity to, the antenna. Shielding cans covering the switch are not required, and they can be in close vicinity to the PA. The switch can be mounted on a flexible PWB.

Application Diagram and Guidelines

The series coupling capacitors are required for pins 1, 3, 4, 5, 7, 9, 11, 13, and 15. Decoupling capacitors on the control pins protect the control circuitry from possible RF leakage. To protect the switch from ESD from the antenna, an ESD filter (L1) is needed. The switch has a supply input to feed the built-in logic decoding. All unused ports require a series decoupling capacitor followed by a shunt 50Ω resistor to ground.

Evaluation Board Layout Board Size 1.5" Diameter

Board Thickness 0.0656", Board Material FR-4 and Rogers R04003

