



**Features**

- 23.5dBm Typical Output Power
- 0dB to 28dB Variable Gain
- 45% Efficiency at Max Output
- On-Board Power Down Mode
- 2.4GHz to 2.5GHz Operation
- 902MHz to 928MHz Operation

**Applications**

- Bluetooth™ PA
- 2.4GHz to 2.5GHz ISM Band Systems
- 902MHz to 928MHz ISM Band Systems
- 3.6V Spread-Spectrum Cordless Phones
- Portable Battery-Powered Equipment
- Spread-Spectrum Systems

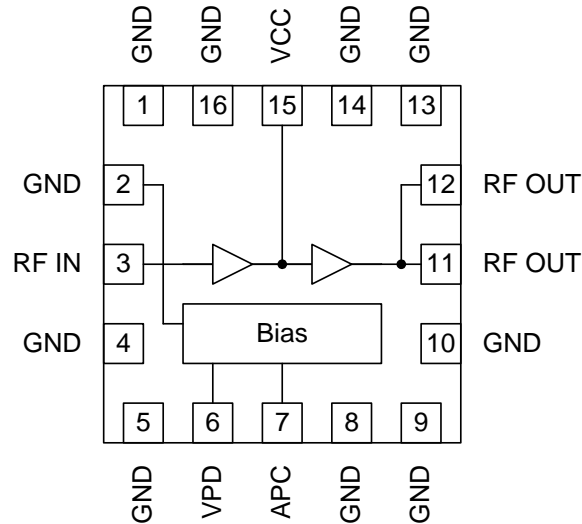

Functional Block Diagram

**Product Description**

The RF2172 is a medium-power high efficiency amplifier IC targeting 3.6V handheld systems. The device is manufactured on an advanced Gallium Arsenide Heterojunction Bipolar Transistor (HBT) process, and has been designed for use as the final RF amplifier in 2.45GHz Bluetooth applications and frequency hopping/direct sequence spread-spectrum cordless telephones or other applications in the 902MHz to 928MHz ISM band. The device is packaged in a compact 4mmx4mm QFN. The device features analog gain control to optimize transmit power while maximizing battery life in portable equipment requiring up to 100mW transmit power at the antenna port.

BLUETOOTH is a trademark owned by the Bluetooth SIG, Inc., and licensed to RF Micro Devices, Inc.

**Optimum Technology Matching® Applied**

- |  |                                      |                                     |                                   |
|--|--------------------------------------|-------------------------------------|-----------------------------------|
| <input checked="" type="checkbox"/> GaAs HBT | <input type="checkbox"/> SiGe BiCMOS | <input type="checkbox"/> GaAs pHEMT | <input type="checkbox"/> GaN HEMT |
| <input type="checkbox"/> GaAs MESFET         | <input type="checkbox"/> Si BiCMOS   | <input type="checkbox"/> Si CMOS    | <input type="checkbox"/> RF MEMS  |
| <input type="checkbox"/> InGaP HBT           | <input type="checkbox"/> SiGe HBT    | <input type="checkbox"/> Si BJT     |                                   |

RF MICRO DEVICES®, RFMD®, Optimum Technology Matching®, Enabling Wireless Connectivity™, PowerStar®, POLARIS™ TOTAL RADIO™ and UltimateBlue™ are trademarks of RFMD, LLC. BLUETOOTH is a trademark owned by Bluetooth SIG, Inc., U.S.A. and licensed for use by RFMD. All other trade names, trademarks and registered trademarks are the property of their respective owners. ©2006, RF Micro Devices, Inc.

## Absolute Maximum Ratings

| Parameter                          | Rating       | Unit            |
|------------------------------------|--------------|-----------------|
| Supply Voltage (RF off)            | -0.5 to +6.0 | V <sub>DC</sub> |
| APC Current (Maximum)              | +10          | mA              |
| Control Voltage (V <sub>PD</sub> ) | -0.5 to +6.0 | V <sub>DC</sub> |
| Input RF Power                     | +10          | dBm             |
| Operating Case Temperature         | -40 to +85   | °C              |
| Storage Temperature                | -55 to +155  | °C              |



**Caution!** ESD sensitive device.

Exceeding any one or a combination of the Absolute Maximum Rating conditions may cause permanent damage to the device. Extended application of Absolute Maximum Rating conditions to the device may reduce device reliability. Specified typical performance or functional operation of the device under Absolute Maximum Rating conditions is not implied.

RoHS status based on EUDirective2002/95/EC (at time of this document revision).

The information in this publication is believed to be accurate and reliable. However, no responsibility is assumed by RF Micro Devices, Inc. ("RFMD") for its use, nor for any infringement of patents, or other rights of third parties, resulting from its use. No license is granted by implication or otherwise under any patent or patent rights of RFMD. RFMD reserves the right to change component circuitry, recommended application circuitry and specifications at any time without prior notice.

| Parameter                | Specification |                      |      | Unit | Condition  |
|--------------------------|---------------|----------------------|------|------|--|
|                          | Min.          | Typ.                 | Max. |      |  |
| <b>Overall</b>           |               |                      |      |      | T=25°C, V <sub>CC</sub> =3.6V, V <sub>PD</sub> =3.6V, V <sub>APC</sub> =2.5V                 |
| Usable Frequency Range   |               | 500 to 2500          |      | MHz  |  |
| Input Impedance          |               | 50                   |      | Ω    |  |
| Input VSWR               |               | 1.8:1                |      |      | Without Input Match  |
| Output Load VSWR         | <10:1         |                      |      |      | 0 ≤ V <sub>APC</sub> ≤ 3.0V  |
|                          | <6:1          |                      |      |      | 0 ≤ V <sub>APC</sub> ≤ 3.6V  |
| <b>2.45GHz Operation</b> |               |                      |      |      | Freq=2.4GHz to 2.5GHz, P <sub>IN</sub> =0dBm   |
| Operating Frequency      |               | 2.4 to 2.5           |      | GHz  |  |
| Maximum Output Power     | 22            | +23.5                | 24.5 | dBm  |  |
| Total Efficiency         |               | 45                   |      | %    |  |
| Reverse Isolation        |               | -25                  |      | dB   |  |
| Second Harmonic          |               | -45                  |      | dBc  |  |
| Third Harmonic           |               | -40                  |      | dBc  |  |
| All Other Spurious       |               | -50                  |      | dBc  |  |
| Output Load Impedance    |               | 20-j4.5              |      |      | Present to part  |
| Gain Control Voltage     |               | 0 to V <sub>CC</sub> |      | V    |  |
| High Gain                | +22           |                      |      | dB   | V <sub>APC</sub> =3.6V, V <sub>CC</sub> =3.6V, P <sub>IN</sub> =0dBm                         |
| Low Gain                 |               |                      | -10  | dB   | V <sub>APC</sub> =0V, V <sub>CC</sub> =3.6V, P <sub>IN</sub> =0dBm                           |
| <b>902MHz Operation</b>  |               |                      |      |      | Freq=902MHz to 928MHz, P <sub>IN</sub> =-3.0dBm  |
| Operating Frequency      |               | 902 to 928           |      | MHz  |  |
| Maximum Output Power     |               | +24                  |      | dBm  |  |
| Total Efficiency         |               | 58                   |      | %    |  |
| Reverse Isolation        |               | -35                  |      | dB   |  |
| Second Harmonic          |               | -40                  |      | dBc  |  |
| Third Harmonic           |               | -40                  |      | dBc  |  |
| All Other Spurious       |               | -50                  |      | dBc  |  |
| Output Load Impedance    |               | 20-j1.6              |      | W    | Present to part  |
| Gain Control Voltage     |               | 0 to V <sub>CC</sub> |      | V    |  |
| Gain Control Slope       |               | 20                   | dB/V |      |  |
| Gain                     |               | 0 to 28              | dB   |      |  |
| <b>Power Supply</b>      |               |                      |      |      |  |
| Power Supply Voltage     |               | 3.6                  |      | V    |  |
| Power Supply Current     |               | 145                  |      | mA   | V <sub>CC</sub> =3.6V, V <sub>APC</sub> =3.6V, P <sub>IN</sub> =-3dBm, V <sub>PD</sub> =3.6V |
| Idle Current             |               | 35                   | 65   | mA   | V <sub>PD</sub> =3.6V, V <sub>APC</sub> =3.6V, RF P <sub>IN</sub> ≤ -30dBm                   |

| Parameter                 | Specification |      |      | Unit | Condition   |
|---------------------------|---------------|------|------|------|---|
|                           | Min.          | Typ. | Max. |      |   |
| <b>Power Down Current</b> |               | 2.8  | 10   | μA   | $V_{CC}=3.6V, V_{APC}=0V, V_{PD}=0V$ total $I_{CC}$ |
| I(PD)                     |               | 4.5  |      | mA   | $V_{CC}=3.6V, V_{PD}=3.6V$ into PD pin              |
| I(PD)                     |               | 2.25 |      | mA   | $V_{CC}=3.0V, V_{PD}=3.0V$ into PD pin              |

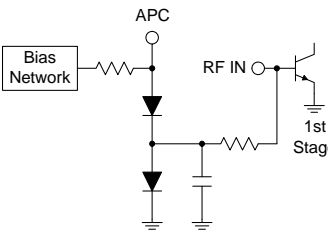
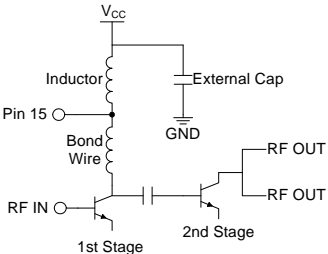
| Pin      | Function | Description   | Interface Schematic   |
|----------|----------|---|---|
| 1        | GND      | Ground connection. For best performance, keep traces physically short and connect immediately to the ground plane.  |   |
| 2        | GND      | Ground connection for the driver stage. For best performance, keep traces physically short and connect immediately to the ground plane.   |   |
| 3        | RF IN    | RF input. This is a 50Ω input. No external matching is needed. An external DC blocking capacitor is required if this port is connected to a DC path to ground or a DC voltage.  | See pin 15.   |
| 4        | GND      | See pin 1.  |   |
| 5        | GND      | See pin 1.  |   |
| 6        | VPD      | Power down pin. When this pin is 0V, the device will be in power down mode, dissipating minimum DC power. This pin also serves as the V <sub>CC</sub> supply pin for the bias circuitry. V <sub>PD</sub> should be at the supply voltage when the part is not in power down mode.   |   |
| 7        | APC      | Analog power control. Output power varies as a function of the voltage on this pin. See graph. This pin must be driven through a series resistor with a voltage between 0V and V <sub>CC</sub> . Series resistor determines dynamic range of power control. See plot "P <sub>OUT</sub> versus Gain Control versus Gain Control Resistor". |    |
| 8        | GND      | See pin 1.  |   |
| 9        | GND      | See pin 1.  |   |
| 10       | GND      | See pin 1.  |   |
| 11       | RF OUT   | RF output. An external matching network is required to provide the optimum load impedance at this pin.  | See pin 15.   |
| 12       | RF OUT   | RF output and power supply for the output stage. Bias voltage for the output stage is provided through this pin. A shunt cap resonating with the bond wire inductance at 2x <sub>f<sub>0</sub></sub> can also be used at this pin to provide a second harmonic trap.  | See pin 15.   |
| 13       | GND      | See pin 1.  |   |
| 14       | GND      | See pin 1.  |   |
| 15       | VCC      | Power supply for driver stage and interstage matching. This pin forms the shunt inductance needed for proper tuning of the interstage. Refer to the application schematic for the proper configuration. Note: Position and value of the components are important.   |  |
| 16       | GND      | See pin 1.  |   |
| Pkg Base | GND      | Ground connection for the output stage. This pad should be connected to the groundplane by vias directly under the device. A short path is required to obtain optimum performance, as well as provide a good thermal path to the PCB for maximum heat dissipation.  |   |

Package Drawing

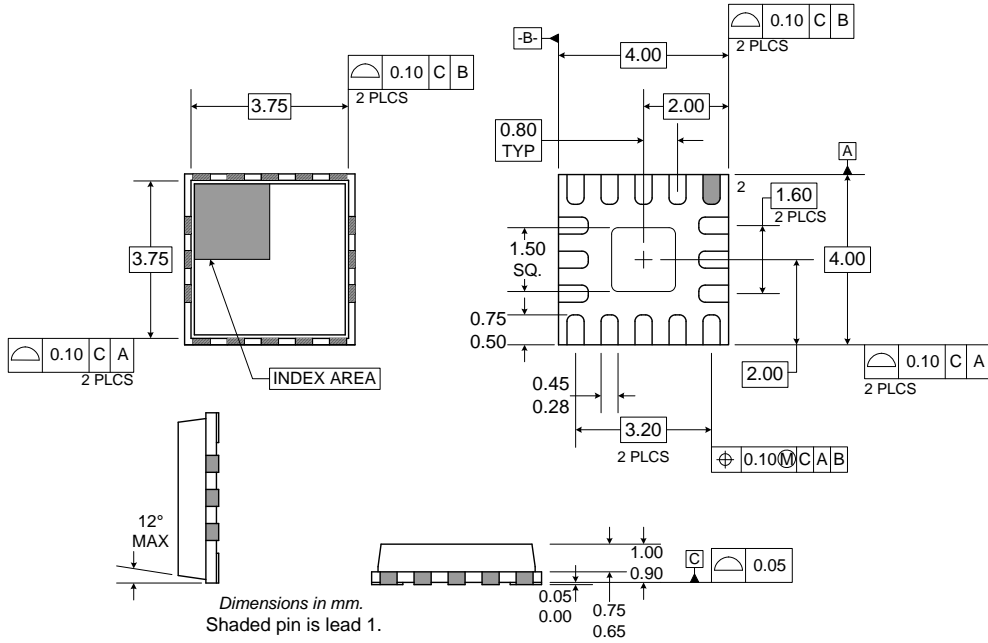

## Application Schematic - 915 MHz

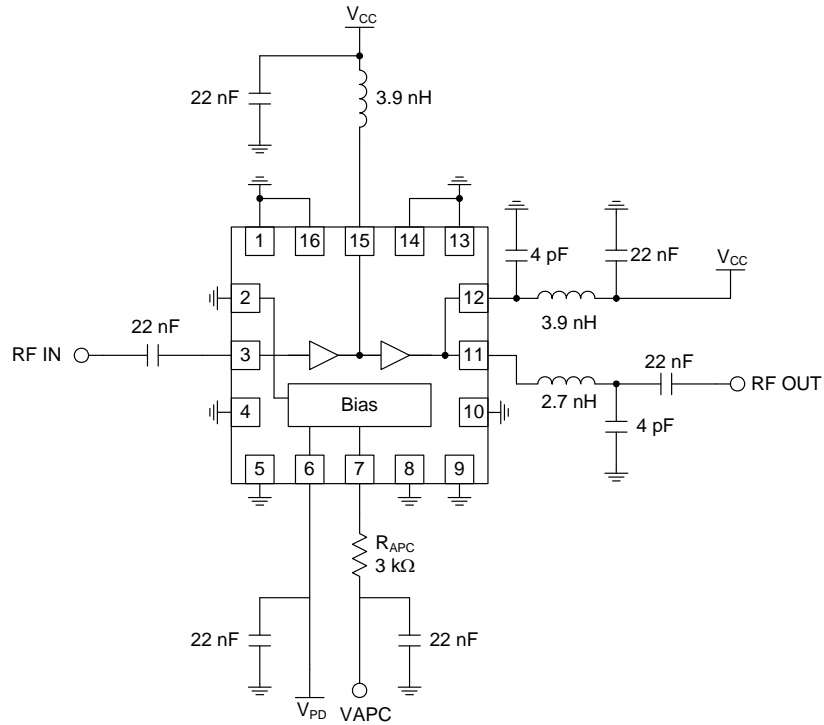

**Application Schematic - 2.45GHz**

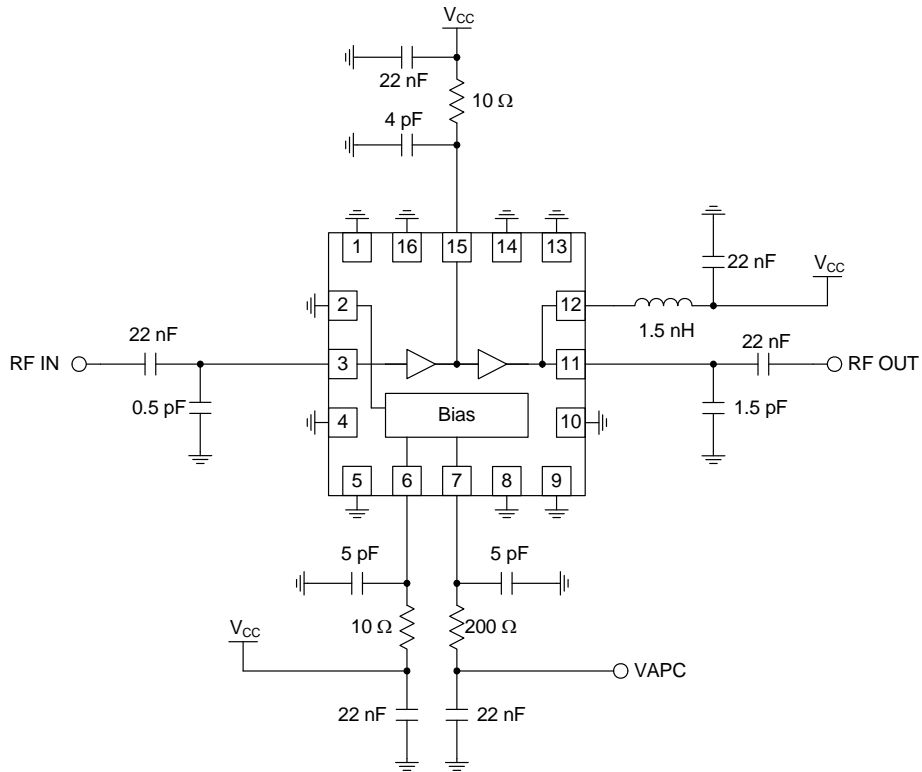

## Evaluation Board Schematic - 915 MHz

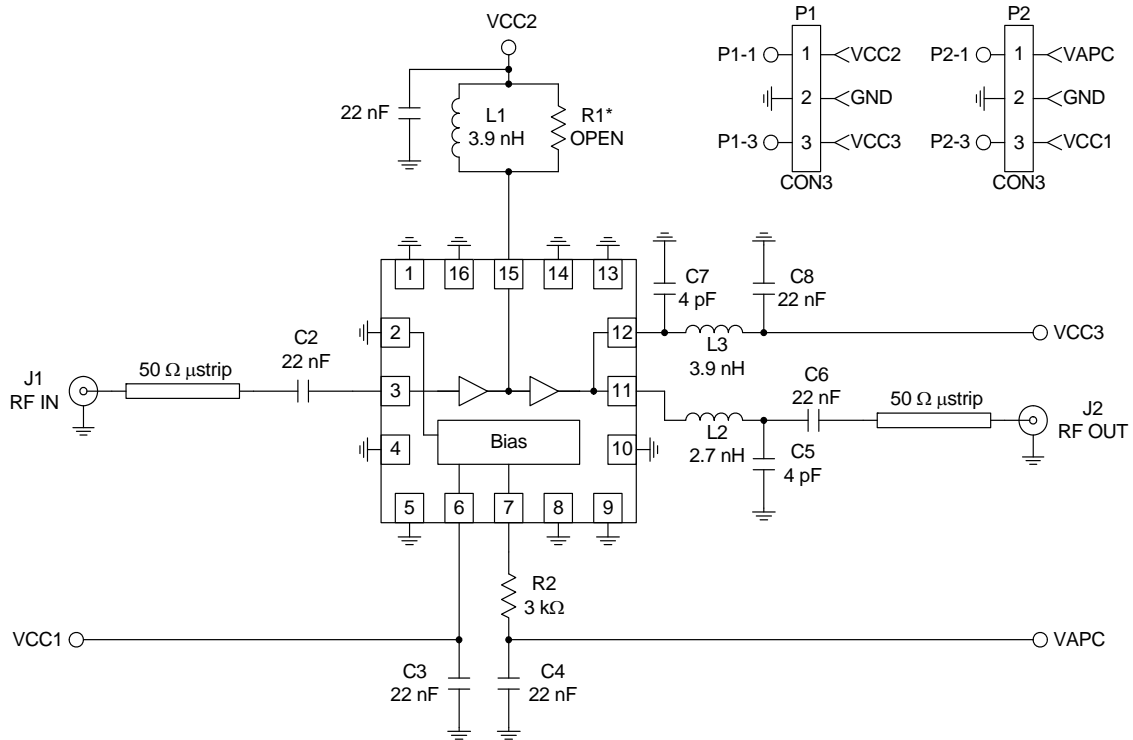



**Evaluation Board Schematic - 2.45GHz**

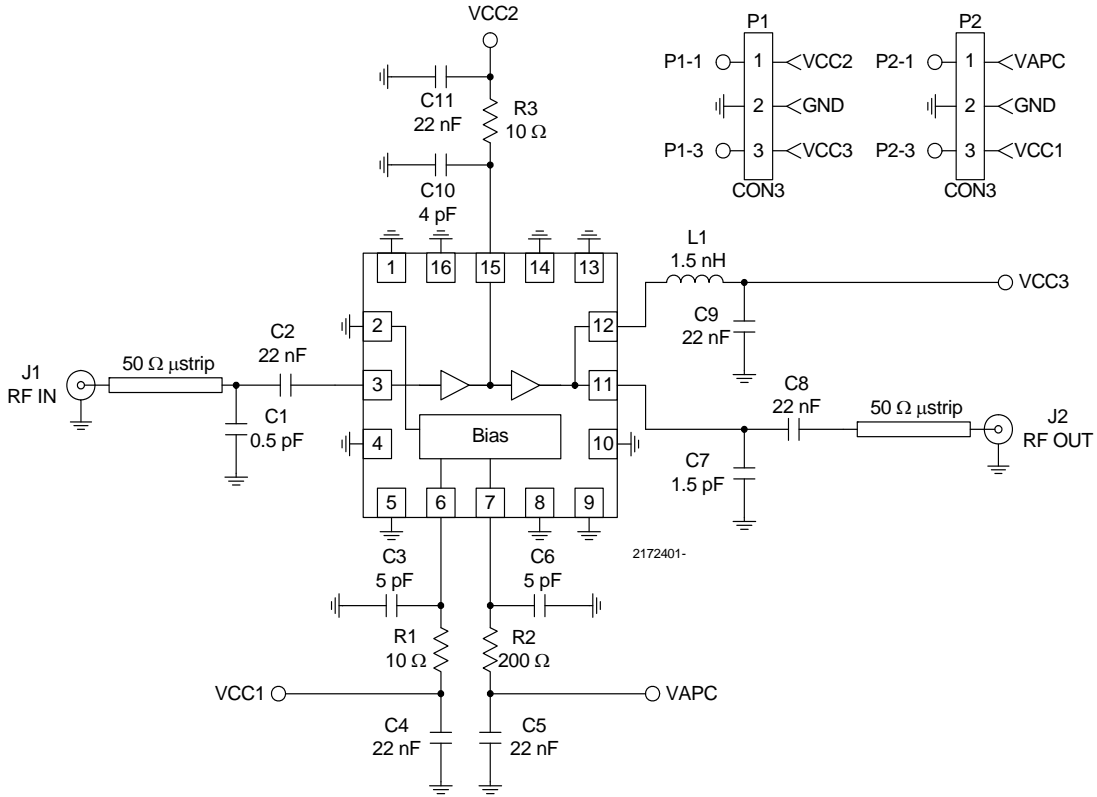

## Evaluation Board Layout - 915MHz Board Size 0.80" x 0.85" Board Thickness 0.031", Board Material FR-4

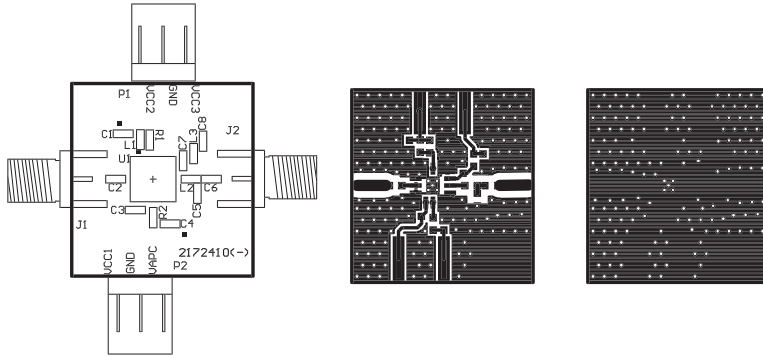

## Evaluation Board Layout - 2.45GHz Board Size 0.800" x 0.924" Board Thickness 0.031", Board Material FR-4

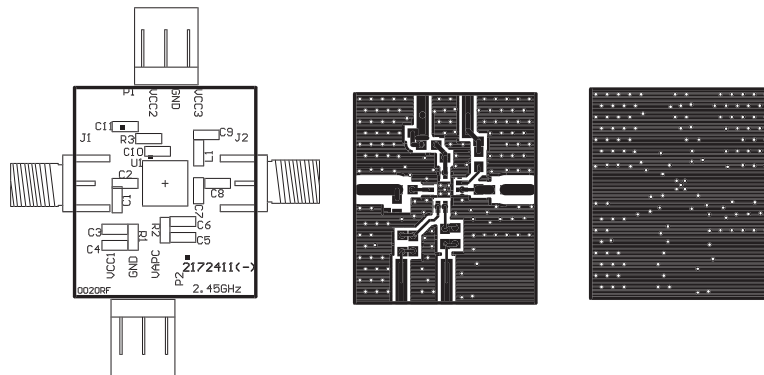

## PCB Design Requirements

### PCB Surface Finish

The PCB surface finish used for RFMD's qualification process is electroless nickel, immersion gold. Typical thickness is 3µinch to 8µinch gold over 180µinch nickel.

### PCB Land Pattern Recommendation

PCB land patterns are based on IPC-SM-782 standards when possible. The pad pattern shown has been developed and tested for optimized assembly at RFMD; however, it may require some modifications to address company specific assembly processes. The PCB land pattern has been developed to accommodate lead and package tolerances.

### PCB Metal Land Pattern

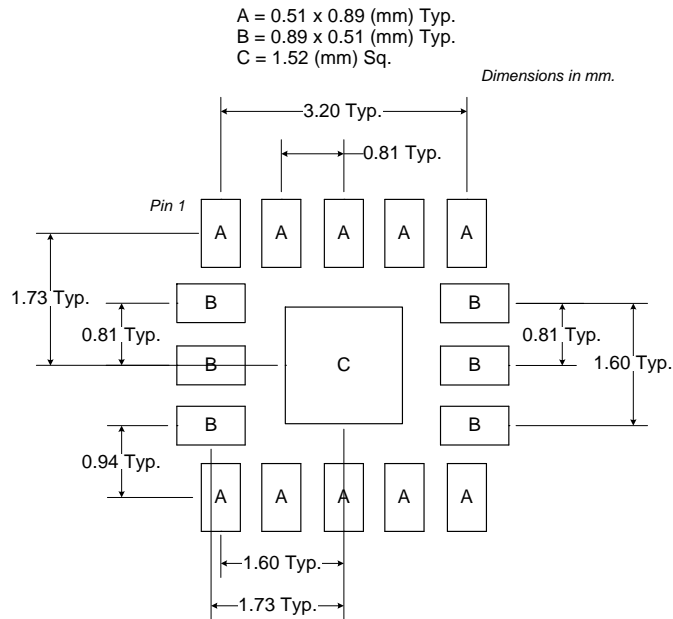
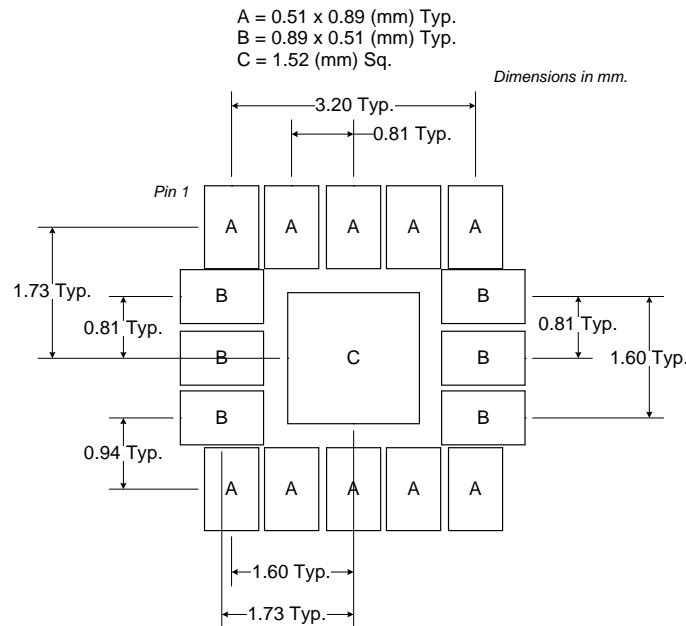

Figure 1. PCB Metal Land Pattern (Top View)

## PCB Solder Mask Pattern

Liquid Photo-Imageable (LPI) solder mask is recommended. The solder mask footprint will match what is shown for the PCB metal land pattern with a 2mil to 3mil expansion to accommodate solder mask registration clearance around all pads. The center-grounding pad shall also have a solder mask clearance. Expansion of the pads to create solder mask clearance can be provided in the master data or requested from the PCB fabrication supplier.



**Figure 2. PCB Solder Mask (Top View)**

## Thermal Pad and Via Design

The PCB metal land pattern has been designed with a thermal pad that matches the die paddle size on the bottom of the device.

Thermal vias are required in the PCB layout to effectively conduct heat away from the package. The via pattern has been designed to address thermal, power dissipation and electrical requirements of the device as well as accommodating routing strategies.

The via pattern used for the RFMD qualification is based on thru-hole vias with 0.203mm to 0.330mm finished hole size on a 0.5mm to 1.2mm grid pattern with 0.025mm plating on via walls. If micro vias are used in a design, it is suggested that the quantity of vias be increased by a 4:1 ratio to achieve similar results.

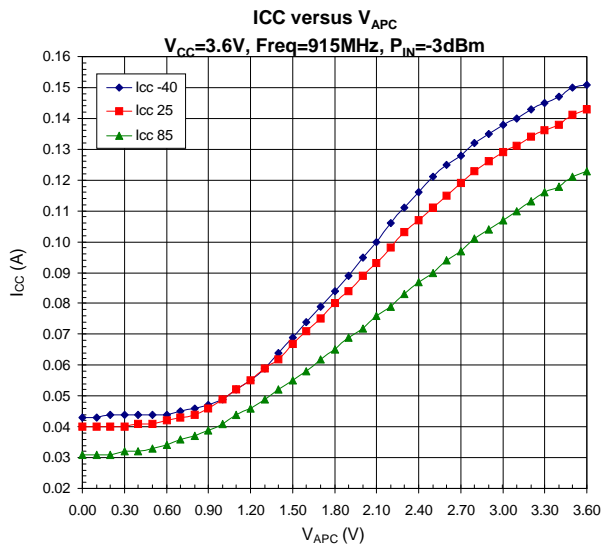
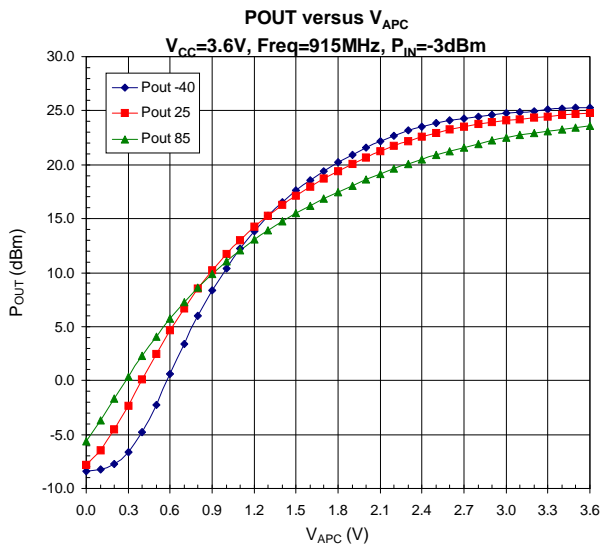
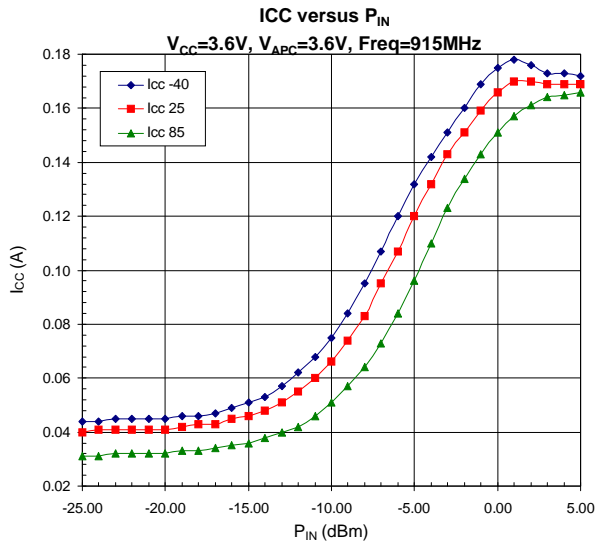
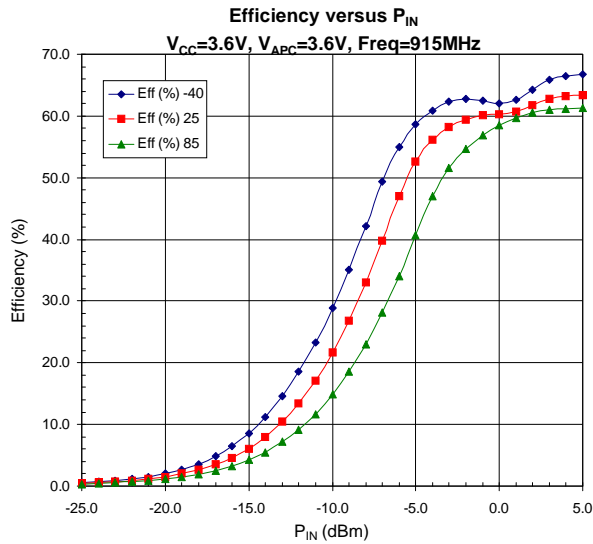
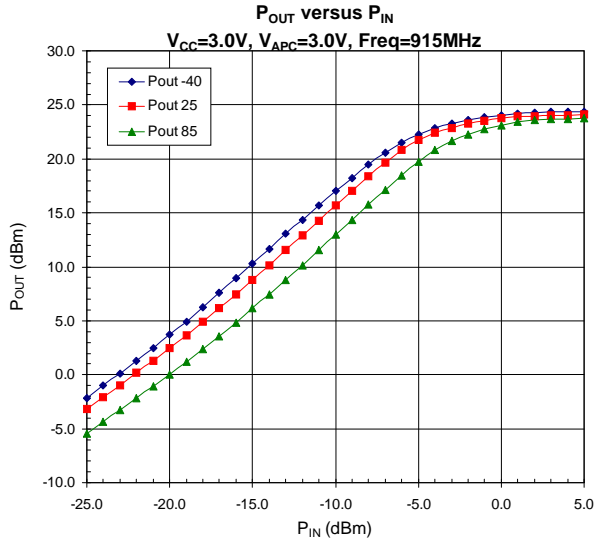
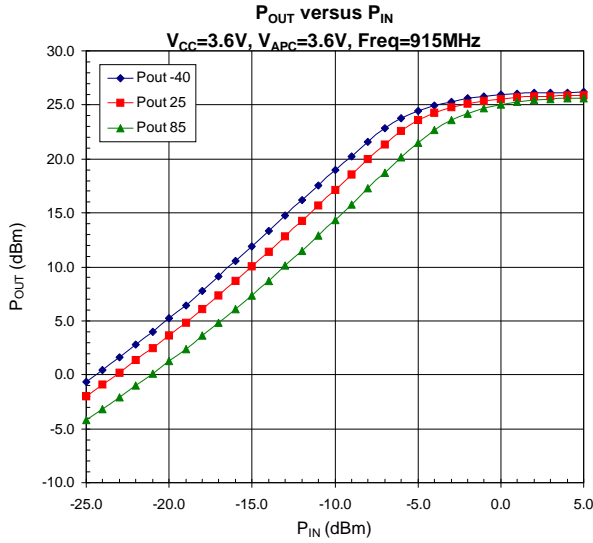

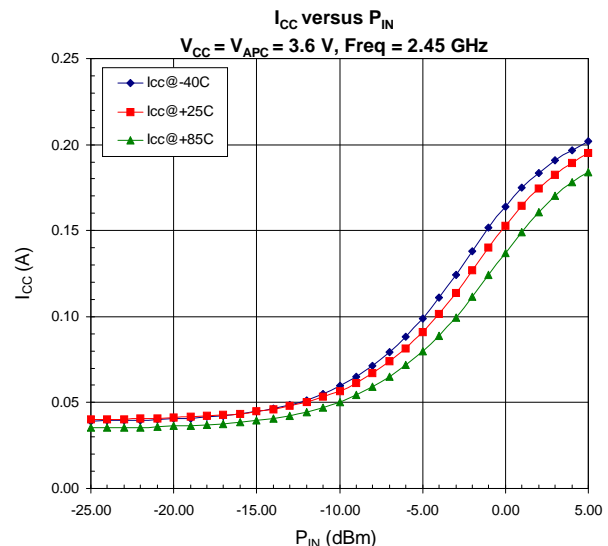
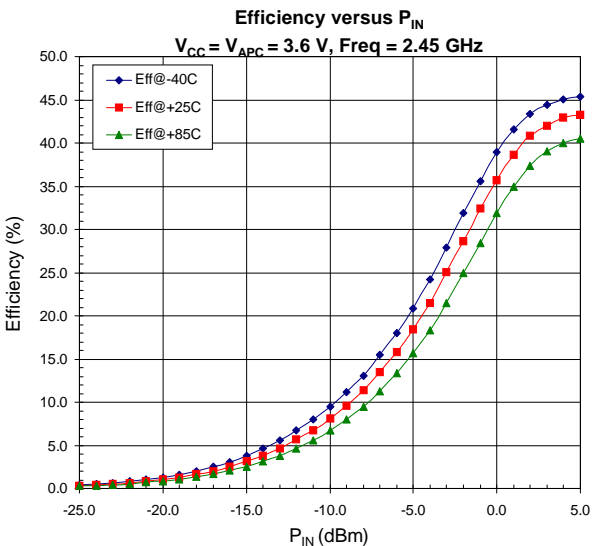
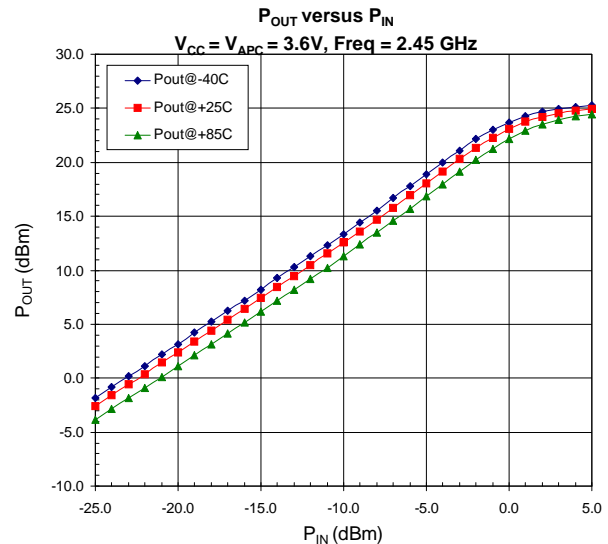
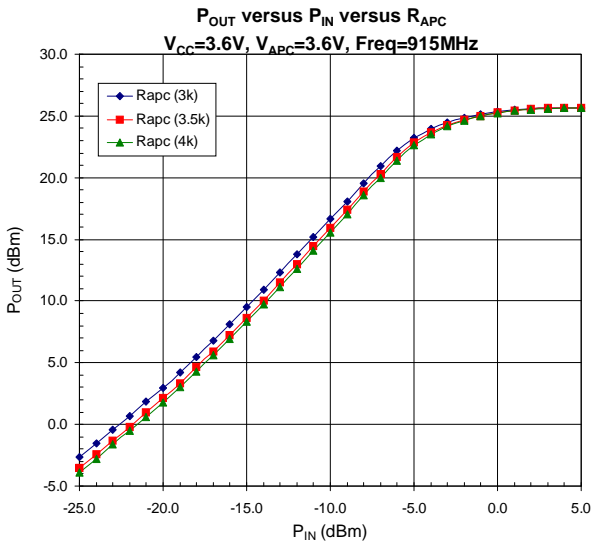
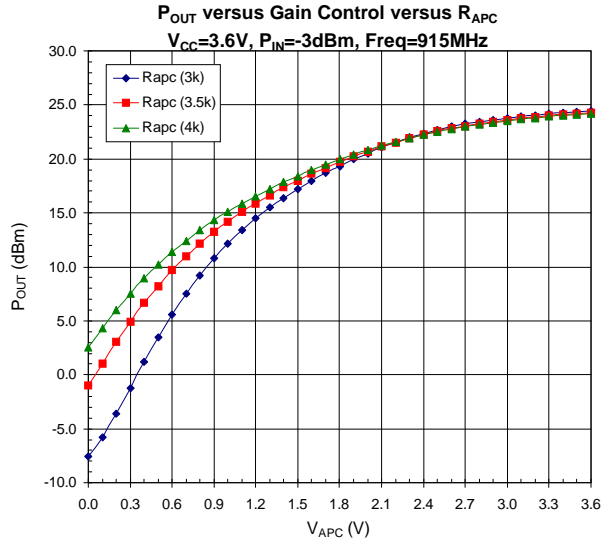
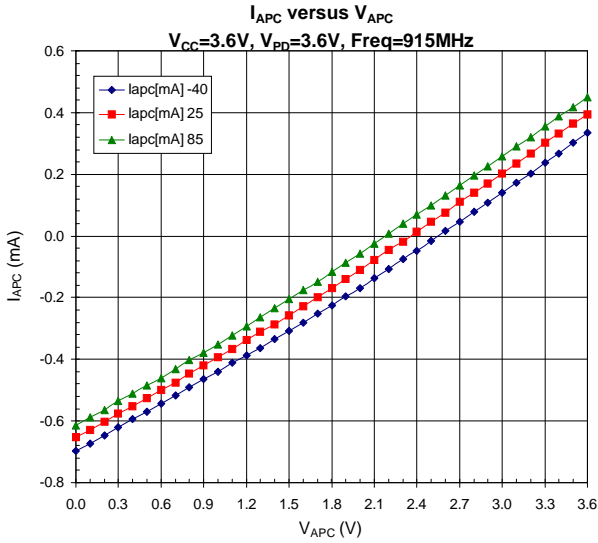

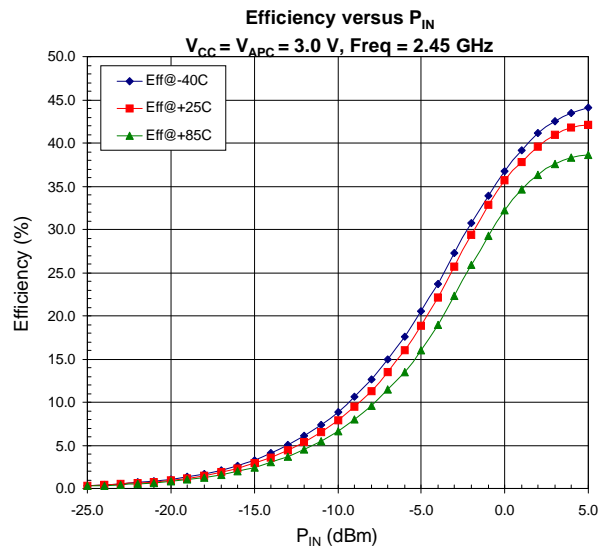
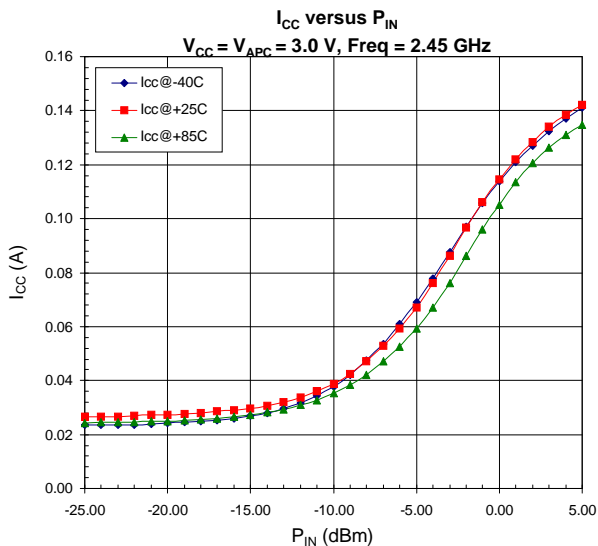
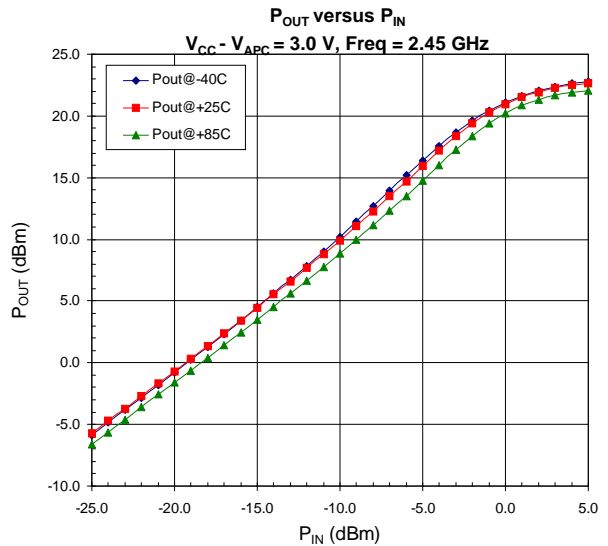
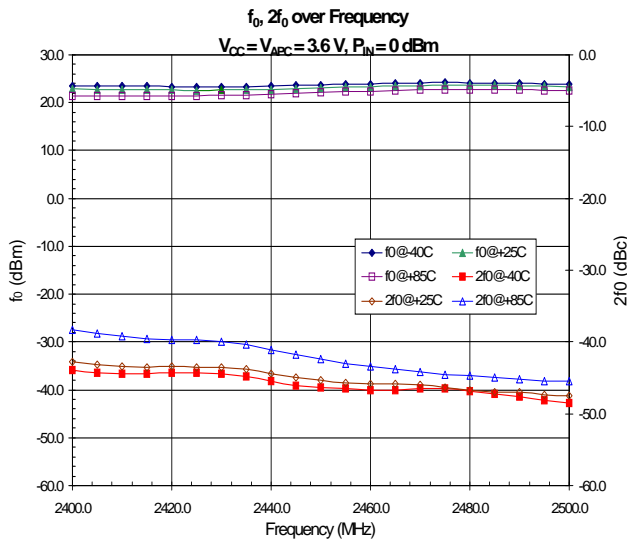
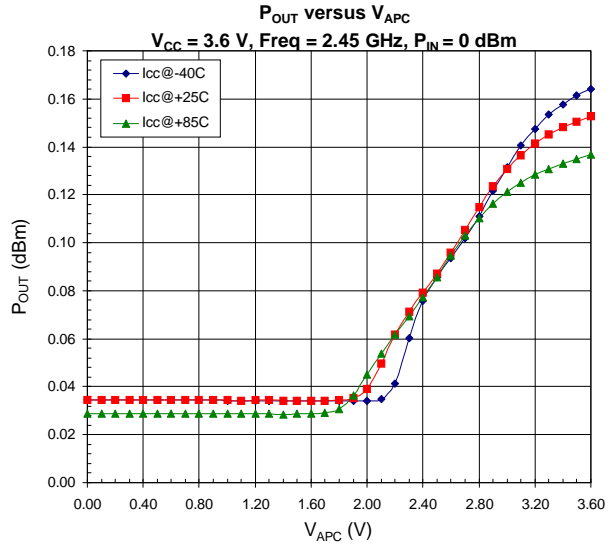
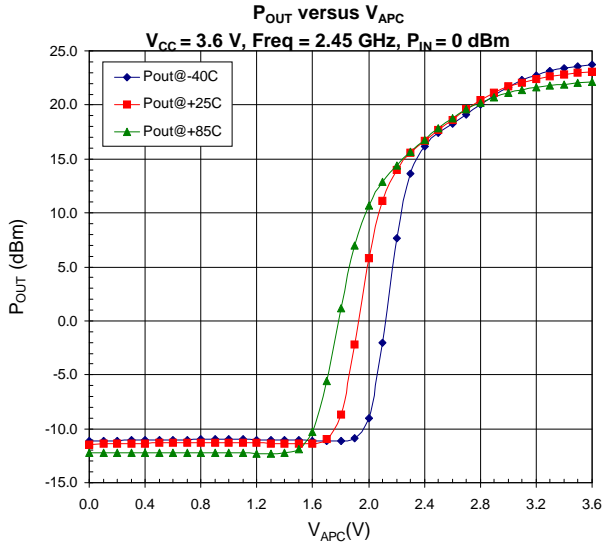

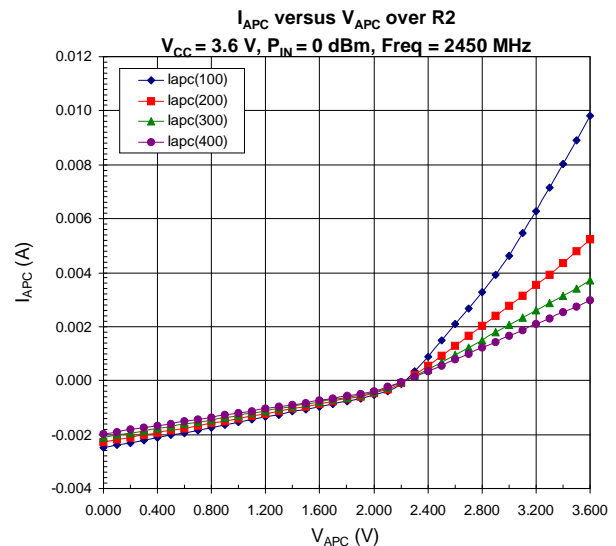
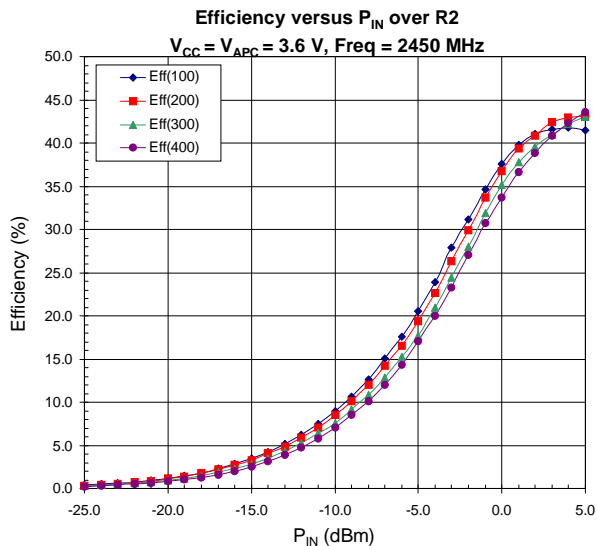
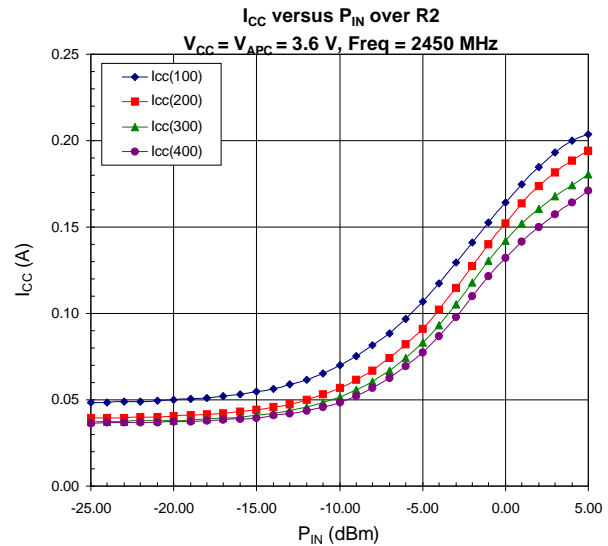
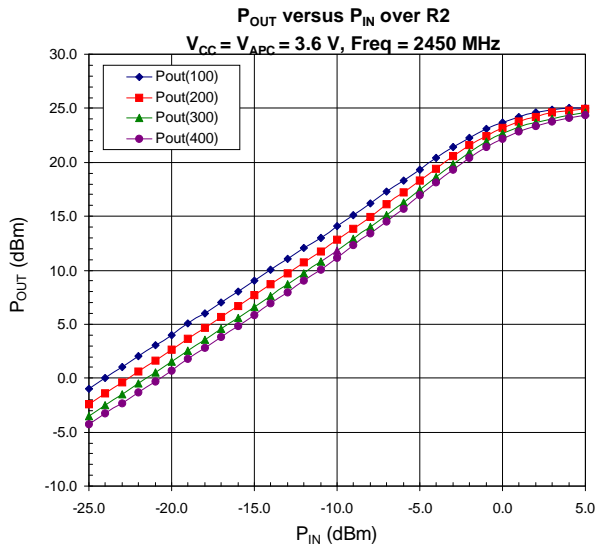
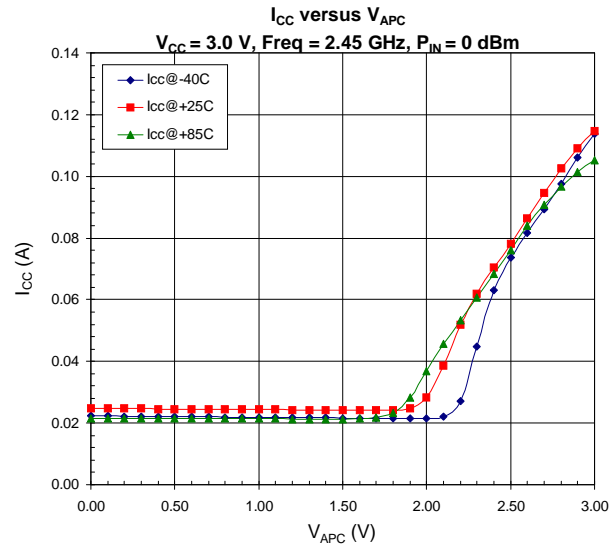
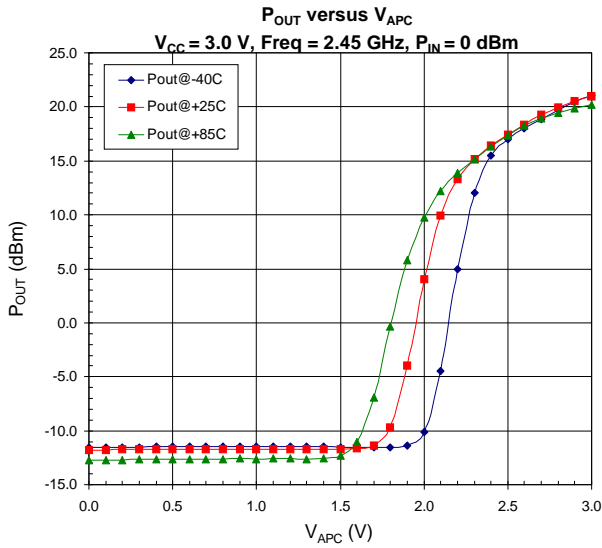



**RoHS\* Banned Material Content**

RoHS Compliant: Yes  
 Package total weight in grams (g): 0.038  
 Compliance Date Code: 0547  
 Bill of Materials Revision: A  
 Pb Free Category: e3

| Bill of Materials | Parts Per Million (PPM) |    |    |       |     |      |
|-------------------|-------------------------|----|----|-------|-----|------|
|                   | Pb                      | Cd | Hg | Cr VI | PBB | PBDE |
| Die               | 0                       | 0  | 0  | 0     | 0   | 0    |
| Molding Compound  | 0                       | 0  | 0  | 0     | 0   | 0    |
| Lead Frame        | 0                       | 0  | 0  | 0     | 0   | 0    |
| Die Attach Epoxy  | 0                       | 0  | 0  | 0     | 0   | 0    |
| Wire              | 0                       | 0  | 0  | 0     | 0   | 0    |
| Solder Plating    | 0                       | 0  | 0  | 0     | 0   | 0    |

This RoHS banned material content declaration was prepared solely on information, including analytical data, provided to RFMD by its suppliers, and applies to the Bill of Materials (BOM) revision noted above.

\* DIRECTIVE 2002/95/EC OF THE EUROPEAN PARLIAMENT AND OF THE COUNCIL of 27 January 2003 on the restriction of the use of certain hazardous substances in electrical and electronic equipment

## Ordering Information

| Ordering Code | Description   |
|---------------|---|
| RF2172        | Standard 25 piece bag   |
| RF2172SR      | Standard 100 piece reel   |
| RF2172TR7     | Standard 750 piece reel   |
| RF2172TR13    | Standard 2500 piece reel  |
| RF2172PCK-411 | Fully assembled evaluation board tuned for 2.4GHz to 2.5GHz and 5 loose sample pieces |
| RF2172PCK-410 | Fully assembled evaluation board tuned for 902MHz to 928MHz and 5 loose sample pieces |