



Package Style: MSOP-8



Features

- Supports Basestation Applications
- -55dB to +51dB Gain Control Range @ 85MHz
- Single 3V Power Supply
- -2dBm Input IP₃
- 12MHz to 385MHz Operation

Applications

- 3V Basestation Systems
- General Purpose Linear IF Amplifier
- Commercial and Consumer Systems
- Portable Battery-Powered Equipment

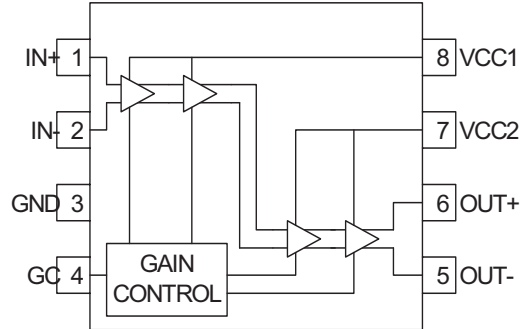

Functional Block Diagram

Product Description

The RF2637 is a complete AGC amplifier designed for the receive section of 3V cellular and PCS applications basestations. It is designed to amplify IF signals while providing more than 90dB of gain control range. Noise Figure, IP₃, and other specifications are designed for basestations. The IC is manufactured on an advanced high frequency SiGe process, and is packaged in a standard miniature 8-lead plastic MSOP package.

Ordering Information

RF2637	Receive AGC Amplifier
RF2637PCBA-41X	Fully Assembled Evaluation Board

Optimum Technology Matching® Applied

- | | | | |
|--------------------------------------|--|-------------------------------------|------------------------------------|
| <input type="checkbox"/> GaAs HBT | <input type="checkbox"/> SiGe BiCMOS | <input type="checkbox"/> GaAs pHEMT | <input type="checkbox"/> GaN HEMT |
| <input type="checkbox"/> GaAs MESFET | <input type="checkbox"/> Si BiCMOS | <input type="checkbox"/> Si CMOS | <input type="checkbox"/> BiFET HBT |
| <input type="checkbox"/> InGaP HBT | <input checked="" type="checkbox"/> SiGe HBT | <input type="checkbox"/> Si BJT | <input type="checkbox"/> LDMOS |

RF MICRO DEVICES®, RFMD®, Optimum Technology Matching®, Enabling Wireless Connectivity™, PowerStar®, POLARIS™ TOTAL RADIO™ and UltimateBlue™ are trademarks of RFMD, LLC. BLUETOOTH is a trademark owned by Bluetooth SIG, Inc., U.S.A. and licensed for use by RFMD. All other trade names, trademarks and registered trademarks are the property of their respective owners. ©2006, RF Micro Devices, Inc.

Absolute Maximum Ratings

Parameter	Value	Unit
Supply Voltage	-0.5 to +5.0	V _{DC}
Control Voltage	-0.5 to +5.0	V _{DC}
Input RF Power	+10	dBm
Operating Ambient Temperature	-40 to +85	°C
Storage Temperature	-40 to +150	°C



Caution! ESD sensitive device.

Exceeding any one or a combination of the Absolute Maximum Rating conditions may cause permanent damage to the device. Extended application of Absolute Maximum Rating conditions to the device may reduce device reliability. Specified typical performance or functional operation of the device under Absolute Maximum Rating conditions is not implied.

The information in this publication is believed to be accurate and reliable. However, no responsibility is assumed by RF Micro Devices, Inc. ("RFMD") for its use, nor for any infringement of patents, or other rights of third parties, resulting from its use. No license is granted by implication or otherwise under any patent or patent rights of RFMD. RFMD reserves the right to change component circuitry, recommended application circuitry and specifications at any time without prior notice.



RFMD Green: RoHS compliant per EU Directive 2002/95/EC, halogen free per IEC 61249-2-21, < 1000ppm each of antimony trioxide in polymeric materials and red phosphorus as a flame retardant, and <2% antimony in solder.

Parameter	Specification			Unit	Condition
	Min.	Typ.	Max.		
Overall					T=25 °C, 85MHz, V _{CC} =3.0V, Z _S =500Ω, Z _L =500Ω, 500Ω External Input Terminating Resistor, 500Ω External Output Terminating Resistor (Effective Z _S =333Ω, Effective Z _L =250Ω) (See Application Example)
Frequency Range		12 to 385		MHz	
Maximum Gain	+40	+51	+65	dB	V _{GC} =2.5V, 85 MHz
Minimum Gain	-65	-55	-40	dB	V _{GC} =0.1V, 85 MHz
Maximum Gain	+35	+45	+55	dB	V _{GC} =2.5V, 385 MHz
Minimum Gain	-68	-58	-48	dB	V _{GC} =0.1V, 385 MHz
Gain Slope		57		dB/V	Note 1
Gain Control Voltage Range		0 to 2.5		V _{DC}	Source impedance of 4.7 kΩ
Gain Control Input Impedance		30		kΩ	
Noise Figure		5	7.2	dB	At maximum gain and 85 MHz
Input IP ₃	-46	-40		dBm	At +40dB gain, referenced to 500Ω
		-2		dBm	At minimum gain, referenced to 500Ω
Stability (Max VSWR)	10:1				Spurious < -70dBm
IF Input					
Input Impedance		1		kΩ	CDMA, differential
Power Supply					
Voltage		2.7 to 3.4		V	
Current Consumption	6	10	15	mA	Minimum gain, V _{CC} =3.0V
	7	11.5	15	mA	Maximum gain, V _{CC} =3.0V
Thermal					
Thermal Resistance		150		°C/W	Theta J-Ref 85 °C
Maximum Junction Temperature		90		°C	Ref 85 °C

Note 1: Measured between a gain control voltage of 1.0V to 1.5V.

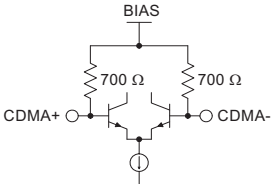
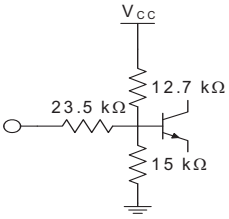
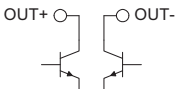
Pin	Function	Description	Interface Schematic
1	IN+	CDMA balanced input pin. This pin is internally DC-biased and should be DC-blocked if connected to a device with a DC level other than V_{CC} present. A DC to connection to V_{CC} is acceptable. For single-ended input operation, one pin is used as an input and the other CDMA input is AC-coupled to ground. The balanced input impedance is $1\text{ k}\Omega$, while the single-ended input impedance is 500Ω .	
2	IN-	Same as pin 2, except complementary input.	See pin 1.
3	GND	Ground connection. For best performance, keep traces physically short and connect immediately to ground plane.	
4	GC	Analog gain adjustment for all amplifiers. Valid control ranges are from 0V to 2.5V. Maximum gain is selected with 2.5V. Minimum gain is selected with 0V. These voltages are only valid for a $4.7\text{ k}\Omega$ DC source impedance.	
5	OUT-	Balanced output pin. This is an open-collector output, designed to operate into a 250Ω balanced load. The load sets the operating impedance, but an external choke or matching inductor to V_{CC} must also be supplied in order to correctly bias this output. This bias inductor is typically incorporated in the matching network between the output and next stage. Because this pin is biased to V_{CC} , a DC-blocking capacitor must be used if the next stage's input has a DC path to ground.	
6	OUT+	Same as pin 5, except complementary output.	See pin 5.
7	VCC2	Supply voltage pin. External bypassing is required. The trace length between the pin and the bypass capacitors should be minimized. The ground side of the bypass capacitors should connect immediately to ground plane.	
8	VCC1	Same as pin 7.	See pin 7.

Package Drawing

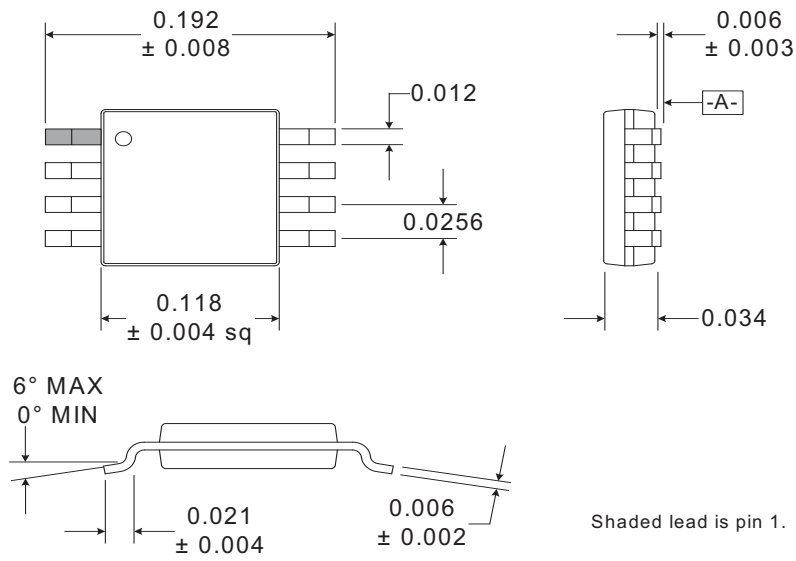

Application Schematic

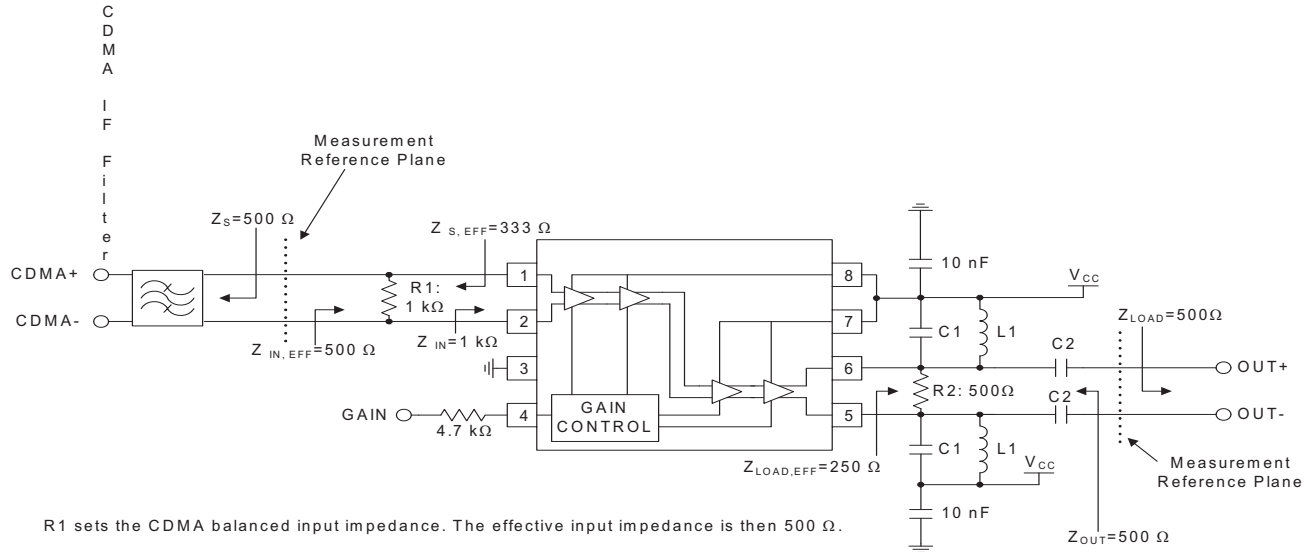

R1 sets the CDMA balanced input impedance. The effective input impedance is then 500 Ω.

R2 sets the balanced output impedance to 500 Ω. L1 and C2 serve dual purposes. L1 serves as an output bias choke, and C2 serves as a series DC block. In addition, the values of L1 and C2 may be chosen to form an impedance matching network of the load impedance is not 500 Ω. Otherwise, the values of L1 and C1 are chosen to form a parallel-resonant tank circuit at the IF when the load impedance is 500 Ω.

Evaluation Board Schematic

(Download [Bill of Materials](http://www.rfmd.com) from www.rfmd.com.)

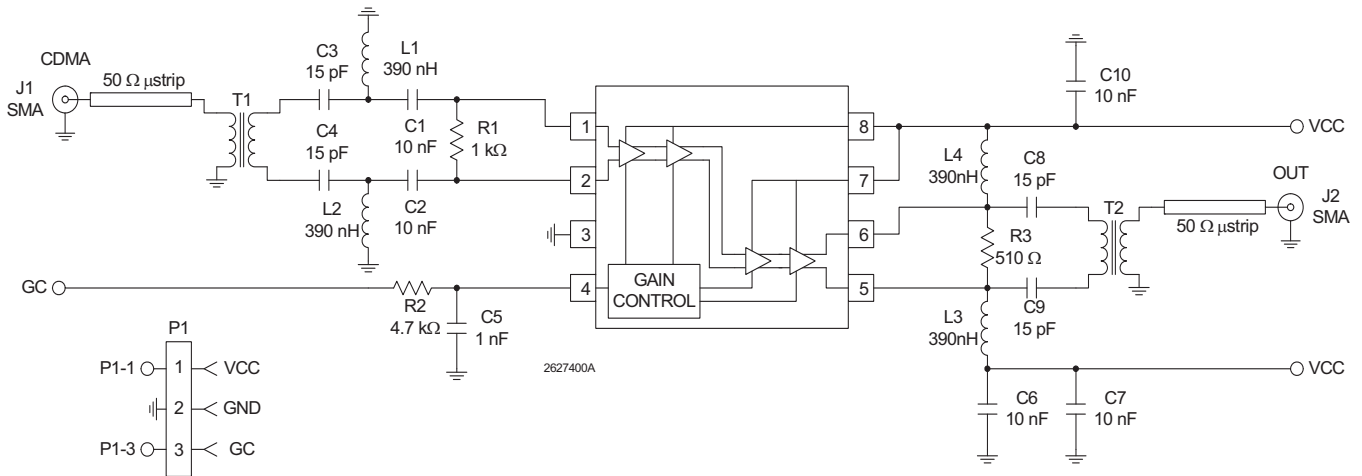

Evaluation Board Layout

Board Size 2.750" x 2.000"
Board Thickness 0.031", Board Material FR-4

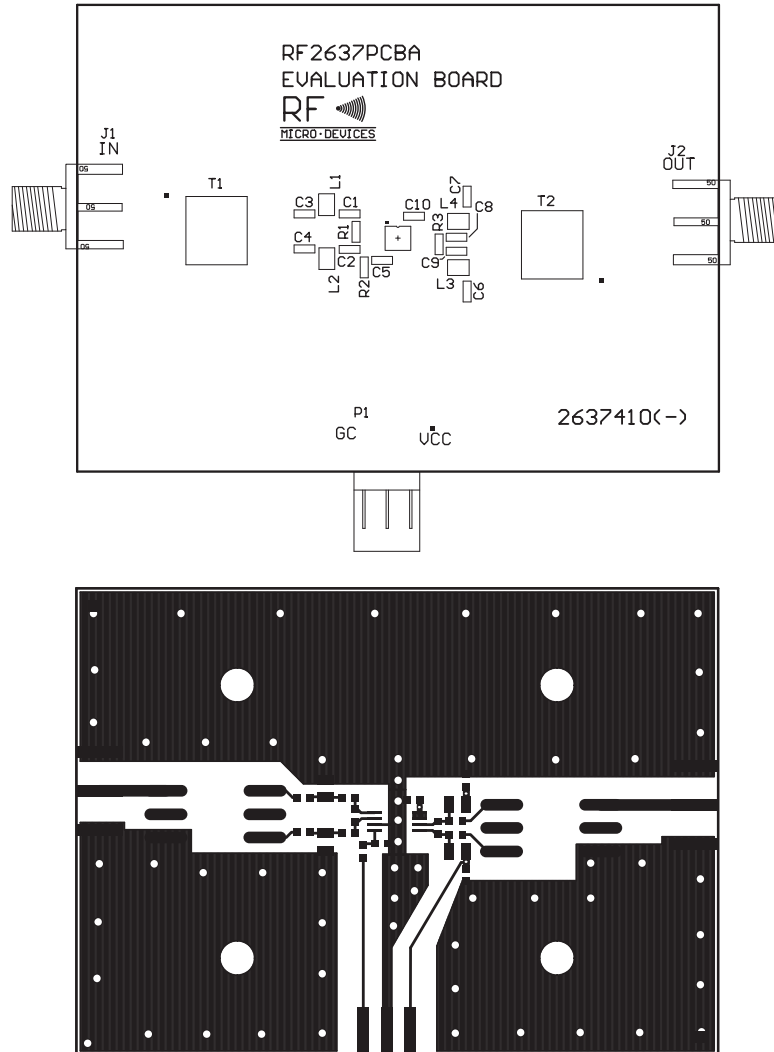

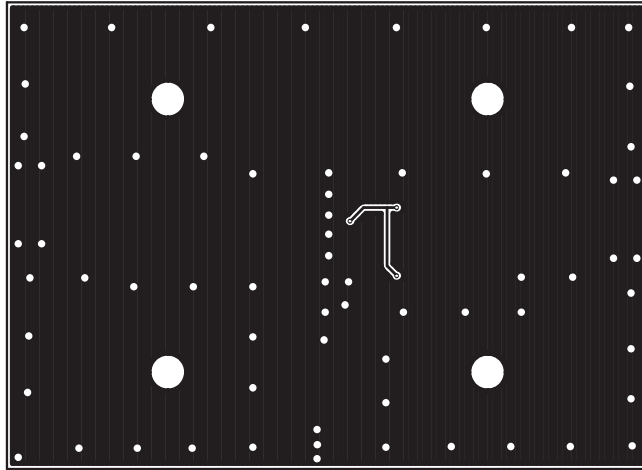

Gain versus V_{GC} Across Temperature,
V_{CC} = 3.0V, F₀ = 85MHz

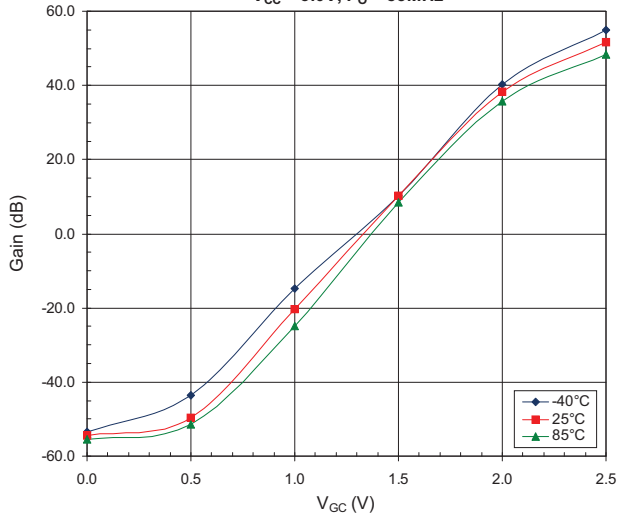

Input IP3 versus V_{GC} Across Temperature,
V_{CC} = 3.0V

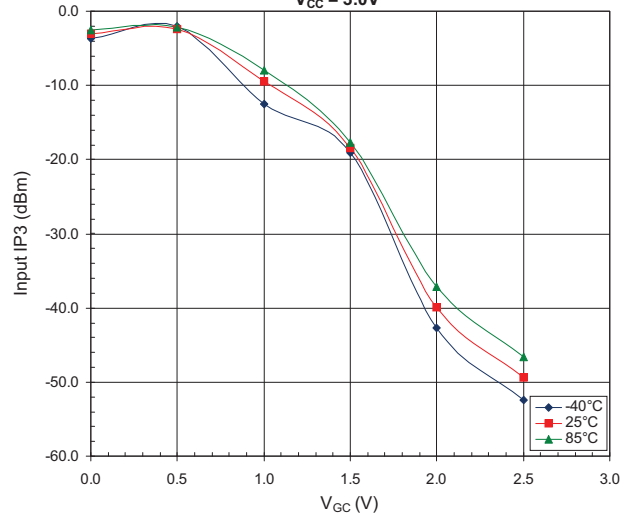

Noise Figure versus Frequency Across Temperature,
V_{CC} = 3.0V, V_{GC} = 2.5V

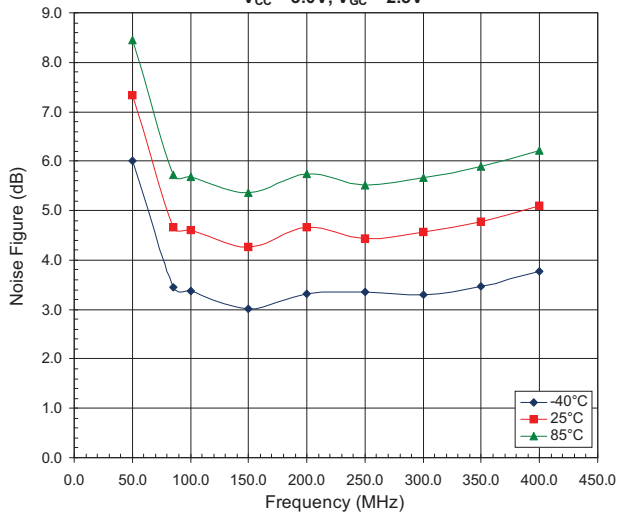

RoHS* Banned Material Content

RoHS Compliant: Yes
 Package total weight in grams (g): 0.025
 Compliance Date Code: N/A
 Bill of Materials Revision: -
 Pb Free Category: e3

Bill of Materials	Parts Per Million (PPM)					
	Pb	Cd	Hg	Cr VI	PBB	PBDE
Die	0	0	0	0	0	0
Molding Compound	0	0	0	0	0	0
Lead Frame	0	0	0	0	0	0
Die Attach Epoxy	0	0	0	0	0	0
Wire	0	0	0	0	0	0
Solder Plating	0	0	0	0	0	0

This RoHS banned material content declaration was prepared solely on information, including analytical data, provided to RFMD by its suppliers, and applies to the Bill of Materials (BOM) revision noted

* DIRECTIVE 2002/95/EC OF THE EUROPEAN PARLIAMENT AND OF THE COUNCIL of 27 January 2003 on the restriction of the use of certain hazardous substances in electrical and electronic equipment