



Features

- Supports Dual Mode Operation
- +10dBm Output IP3 (1950MHz)
- +13dBm Output IP3 (830MHz)
- Single 3.0V Power Supply
- Miniature 8-Pin Package
- Double-Balanced Mixer

Applications

- W-CDMA Systems
- PCS/Cellular CDMA Systems
- PHS 1500/WLAN 2400 Systems
- General Purpose Upconverter
- BPSK Modulation
- Micro-Cell PCS Base Stations

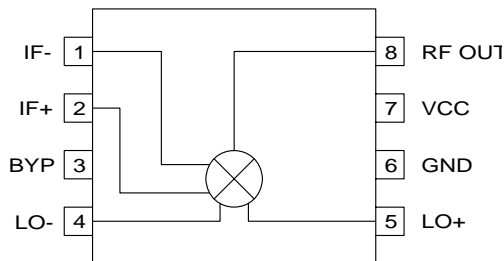

Functional Block Diagram

Product Description

The RF2638 is a complete upconverter designed for cellular, PCS and W-CDMA applications. This device may also be used to directly BPSK modulate a carrier. The unit operates at 3.0V and is designed as part of the RFMD PCS/Cellular CDMA and W-CDMA Chip Sets.

Ordering Information

RF2638 W-CDMA and CDMA Upconverter/ BPSK Modulator
 RF2638 PCBA-PCS/CEL Fully Assembled Evaluation Board
 RF2638 PCBA-DO Fully Assembled Evaluation Board

Optimum Technology Matching® Applied

- | | | | |
|--------------------------------------|---|-------------------------------------|-----------------------------------|
| <input type="checkbox"/> GaAs HBT | <input type="checkbox"/> SiGe BiCMOS | <input type="checkbox"/> GaAs pHEMT | <input type="checkbox"/> GaN HEMT |
| <input type="checkbox"/> GaAs MESFET | <input checked="" type="checkbox"/> Si BiCMOS | <input type="checkbox"/> Si CMOS | |
| <input type="checkbox"/> InGaP HBT | <input type="checkbox"/> SiGe HBT | <input type="checkbox"/> Si BJT | |

RF MICRO DEVICES®, RFMD®, Optimum Technology Matching®, Enabling Wireless Connectivity™, PowerStar®, POLARIS™ TOTAL RADIO™ and UltimateBlue™ are trademarks of RFMD, LLC. BLUETOOTH is a trademark owned by Bluetooth SIG, Inc., U.S.A. and licensed for use by RFMD. All other trade names, trademarks and registered trademarks are the property of their respective owners. ©2006, RF Micro Devices, Inc.

Absolute Maximum Ratings

Parameter	Rating	Unit
Supply Voltage	-0.5 to +5.0	V _{DC}
Input RF Power	+3	dBm
Operating Ambient Temperature	-30 to +80	°C
Storage Temperature	-30 to +150	°C



Caution! ESD sensitive device.

Exceeding any one or a combination of the Absolute Maximum Rating conditions may cause permanent damage to the device. Extended application of Absolute Maximum Rating conditions to the device may reduce device reliability. Specified typical performance or functional operation of the device under Absolute Maximum Rating conditions is not implied.

RoHS status based on EUDirective2002/95/EC (at time of this document revision).

The information in this publication is believed to be accurate and reliable. However, no responsibility is assumed by RF Micro Devices, Inc. ("RFMD") for its use, nor for any infringement of patents, or other rights of third parties, resulting from its use. No license is granted by implication or otherwise under any patent or patent rights of RFMD. RFMD reserves the right to change component circuitry, recommended application circuitry and specifications at any time without prior notice.

Parameter	Specification			Unit	Condition
	Min.	Typ.	Max.		
Overall					T=25 °C, V _{CC} =3.0V
RF Output Frequency Range		500 to 2500		MHz	
Spurious Product Rejection		30		dBc	Referenced to RF output
Cellular					T=25 °C, V _{CC} =3.0V, LO=960MHz@-3dBm, IF=130MHz@-13dBm
Conversion Gain	-1	-0.5		dB	RF _{OUT} =830MHz
	-2.2	-1		dB	RF _{OUT} =836MHz (Dual-Output board)
Noise Figure		14		dB	RF _{OUT} =830MHz
Output IP3		+13		dBm	P _{IN} =-13dBm per Tone, RF out=830MHz
PCS					T=25 °C, V _{CC} =3.0V, LO=1750MHz@-3dBm, IF=130MHz@-13dBm
Conversion Gain	-3.0	-1.5		dB	RF _{OUT} =1880MHz
	-3.5	-2.5		dB	RF _{OUT} =1880MHz (Dual-Output board)
Noise Figure		15		dB	RF _{OUT} =1880MHz
Output IP3	+7	+11		dBm	P _{IN} =-13dBm per Tone, RF out=1880MHz
W-CDMA					T=25 °C, V _{CC} =3.0V, LO=2330MHz@-3dBm, IF=380MHz@-13dBm
ACPR	-58	-57	-56	dBc	
Conversion Gain	-2.0	-1.0	0	dB	RF _{OUT} =1950MHz
Noise Figure	13	14	15	dB	RF _{OUT} =1950MHz
Output IP3	+8	+10		dBm	P _{IN} =-13dBm per Tone, RF _{OUT} =1950MHz
Max OIP3			11	dBm	
IF Input					
IF Frequency	DC	130/380	500	MHz	
Differential Input Impedance	220	260	300	Ω	IF=130MHz
IF to RF Output Isolation		30		dB	
IF to LO Isolation		30		dB	
LO Input					
LO Frequency Range		300 to 2700		MHz	
LO Level		-6 to 0		dBm	
LO to RF Output Leakage	-18	-25		dBm	
	-15	-17		dBm	At Cellular band, high side injection (Dual-Output board)
	-14	-15		dBm	At PCS band, low side injection (Dual-Output board)

Parameter	Specification			Unit	Condition
	Min.	Typ.	Max.		
LO Input, cont.					
RF to LO Isolation		30		dB	
LO Input VSWR		2:1			50Ω
Power Supply					
Voltage	2.7	3.0	3.3	V	
Current Consumption		25		mA	

Pin	Function	Description	Interface Schematic
1	IF-	Balanced IF input pin. This pin is internally DC-biased and should be DC-blocked if connected to a device with a DC level present. For single-ended input operation, one pin is used as an input and the other IF input is AC-coupled to ground. The balanced, input impedance is 260Ω.	
2	IF+	Same as pin 1, except complementary input.	See pin 1.
3	BYP	Bypass pin for internal bias circuitry. Bypass with a 1nF capacitor.	
4	LO-	Balanced LO input pin. This pin is internally DC-biased and should be DC-blocked if connected to a device with a DC level present. For single-ended input operation, one pin is used as an input and the other LO input is AC-coupled to ground.	
5	LO+	Same as pin 4, except complementary input.	See pin 4.
6	GND	Ground connection. For best performance, keep traces physically short and connect immediately to ground plane.	
7	VCC	Supply voltage pin. External bypassing is required. External RF, LO, and IF bypassing is required. The trace length between the pin and the bypass capacitors should be minimized. The ground side of the bypass capacitors should connect immediately to ground plane.	
8	RF OUT	RF output pin.	

Package Drawing

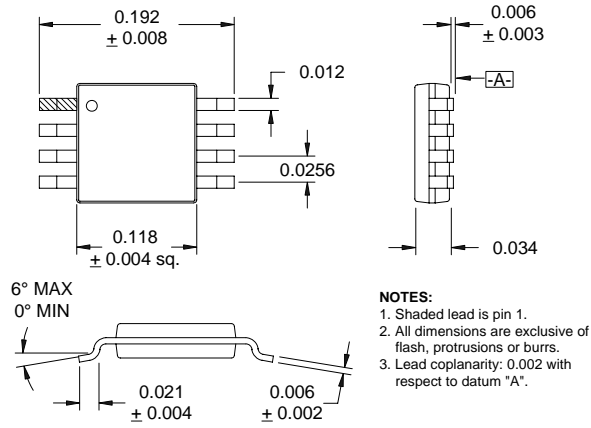

Application Schematic 836 MHz

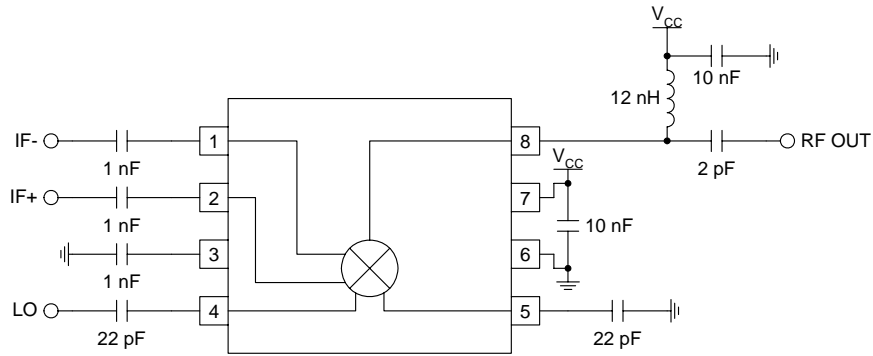

Application Schematic 1880 MHz

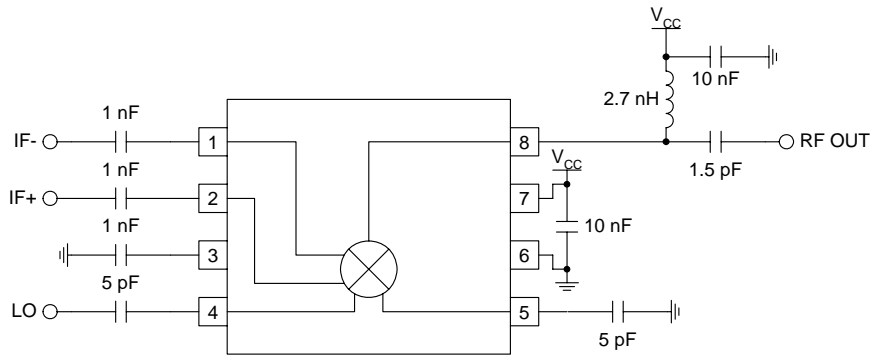

**Application Schematic
Dual-Band Output (836MHz/1880MHz)**

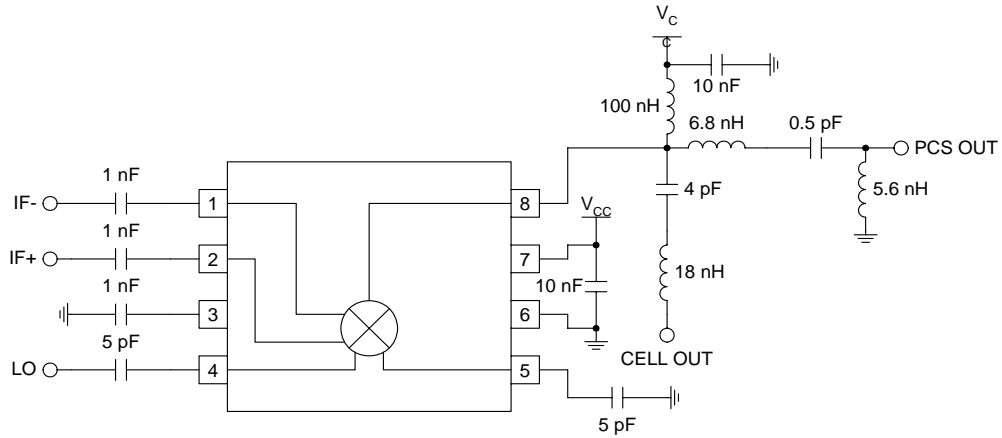

**Application Schematic
W-CDMA (1950MHz)**

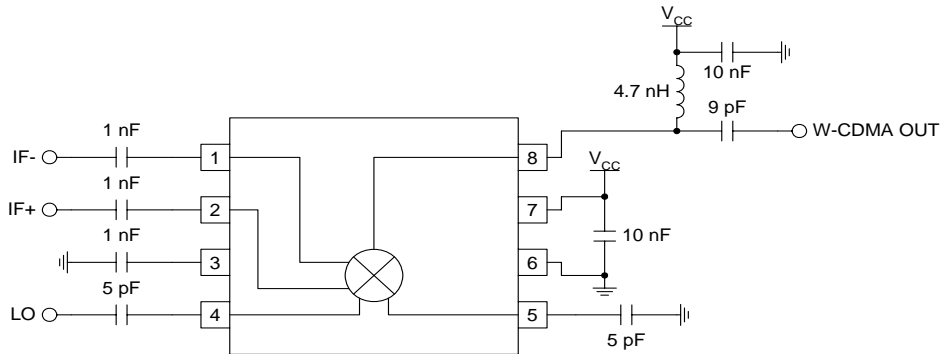

Evaluation Board Schematic - PCS/Cellular RF=1880MHz, IF=130MHz

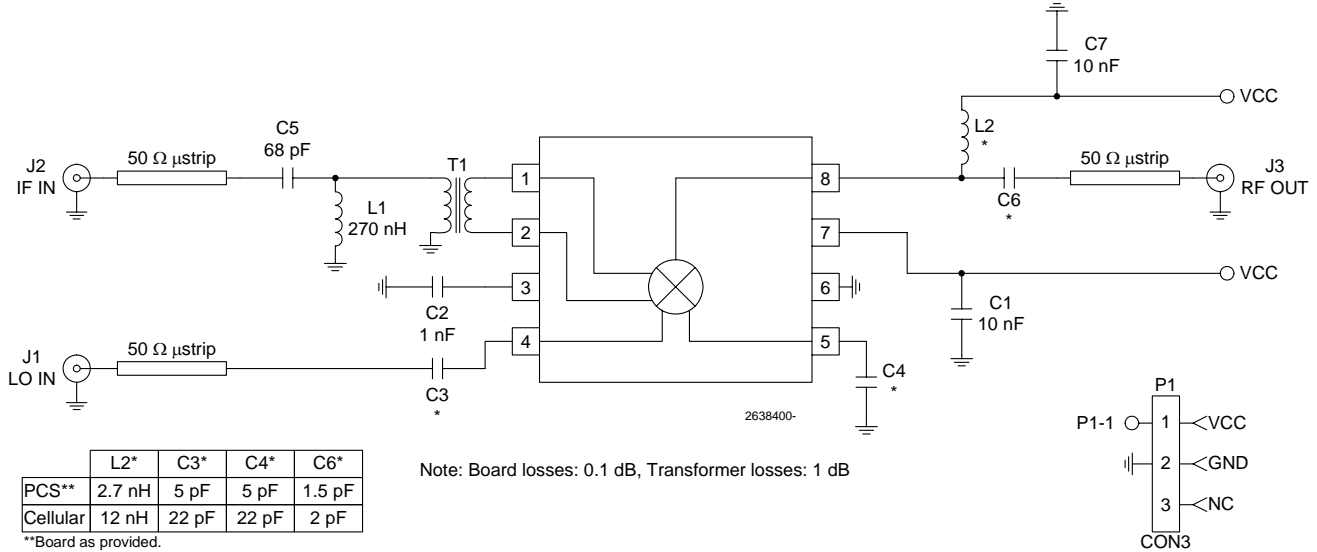

Evaluation Board Schematic - Dual Output Cellular Out=836MHz, PCS Out=1880MHz, IF=130MHz

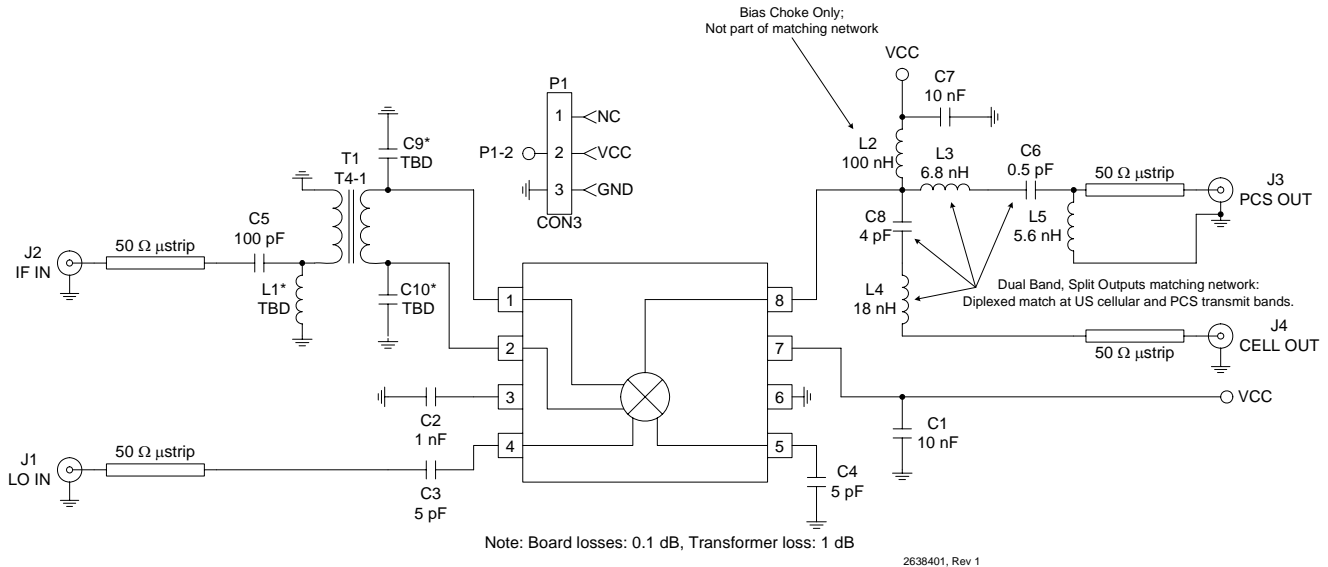

Evaluation Board Schematic - W-CDMA
RF=1950 MHz, IF=380 MHz

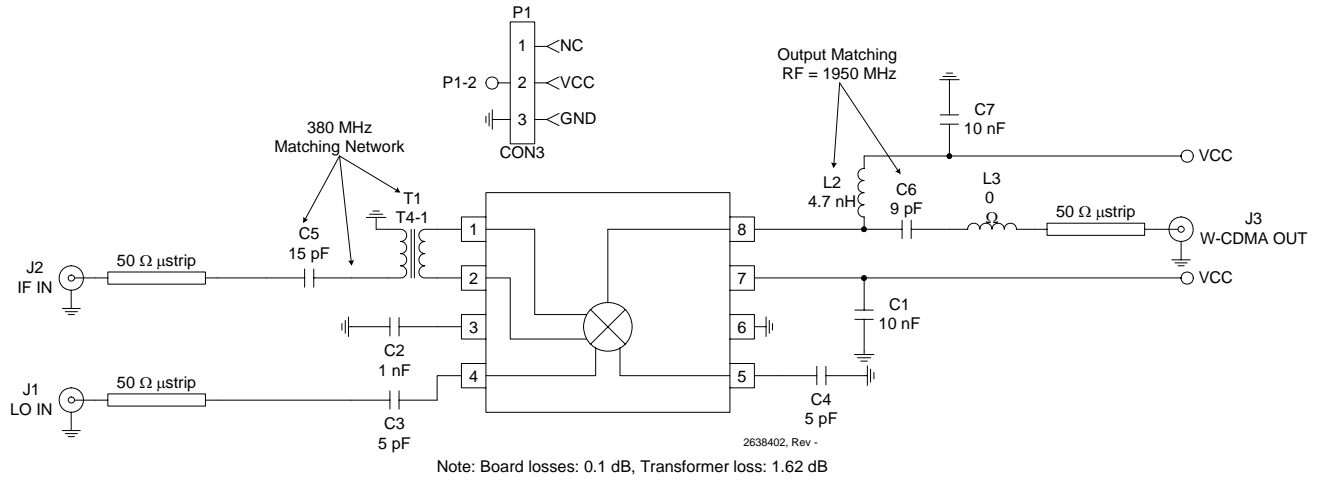

Evaluation Board Layout
PCS/Cellular
Board Size 2.0" x 2.0"
Board Thickness 0.031", Board Material FR-4

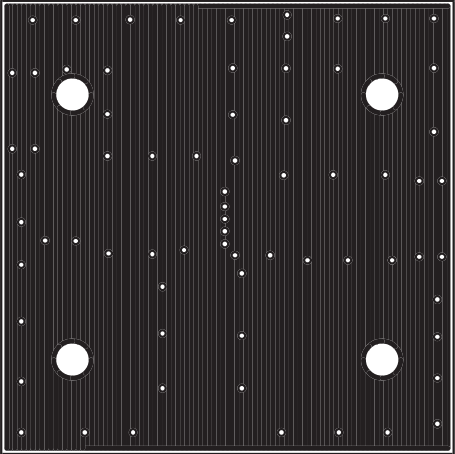
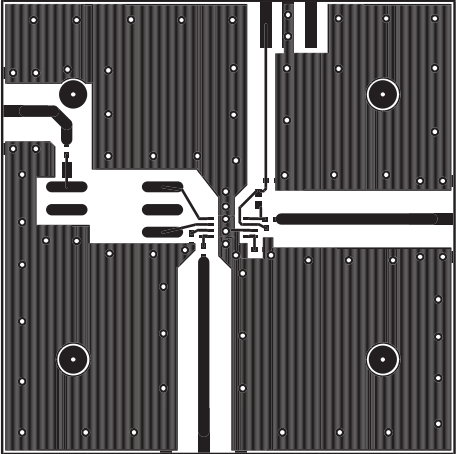
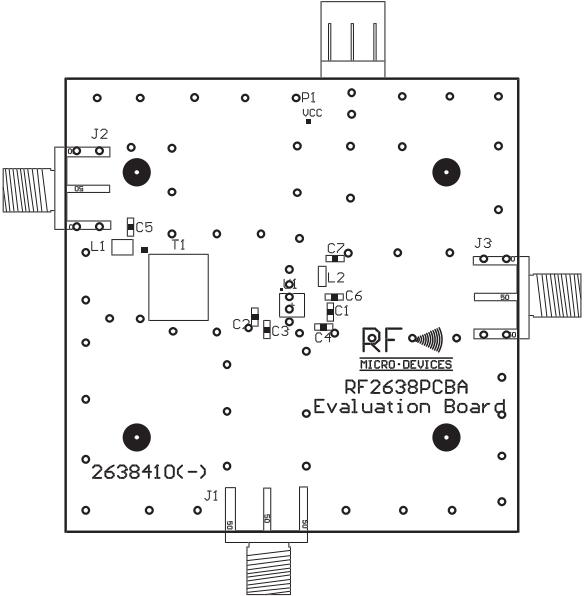

**Evaluation Board Layout
Dual Output**

Board Size 2.5" x 1.0"

Board Thickness 0.060", Board Material FR-4, Multi-Layer

(Intermediate layers (Ground Plane and Power Plane [V_{CC1}]) are not shown.)

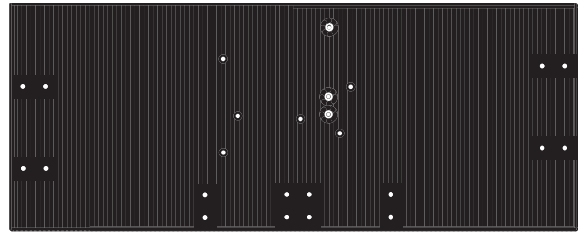
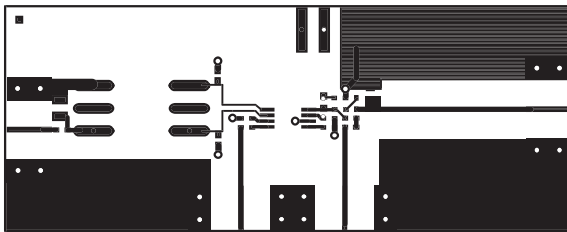
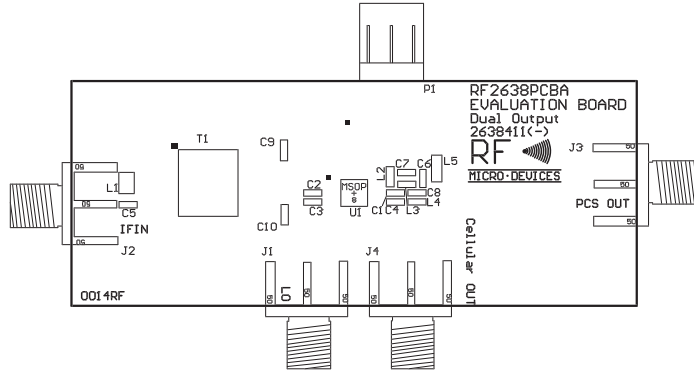

Evaluation Board Layout W-CDMA

Board Size 2.5" x 1.0"

Board Thickness 0.060", Board Material FR-4, Multi-Layer
(Intermediate layers (Ground Plane and Power Plane [V_{CC1}]) are not shown.)

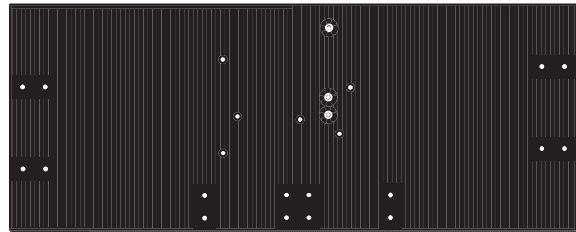
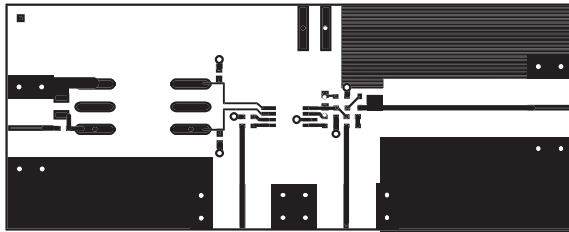
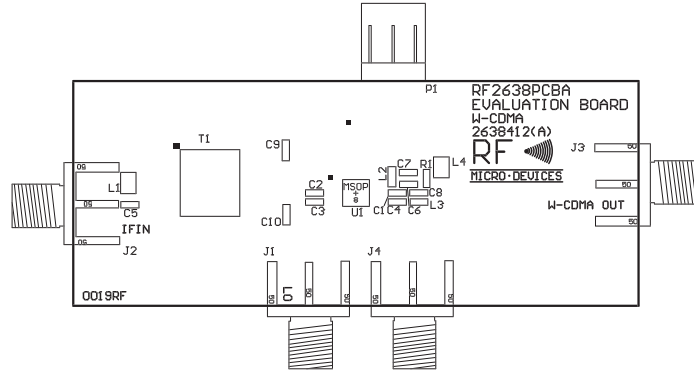

RoHS* Banned Material Content

RoHS Compliant: Yes
 Package total weight in grams (g): 0.025
 Compliance Date Code: 0648
 Bill of Materials Revision: -
 Pb Free Category: e3

Bill of Materials	Parts Per Million (PPM)					
	Pb	Cd	Hg	Cr VI	PBB	PBDE
Die	0	0	0	0	0	0
Molding Compound	0	0	0	0	0	0
Lead Frame	0	0	0	0	0	0
Die Attach Epoxy	0	0	0	0	0	0
Wire	0	0	0	0	0	0
Solder Plating	0	0	0	0	0	0

This RoHS banned material content declaration was prepared solely on information, including analytical data, provided to RFMD by its suppliers, and applies to the Bill of Materials (BOM) revision noted above.

* DIRECTIVE 2002/95/EC OF THE EUROPEAN PARLIAMENT AND OF THE COUNCIL of 27 January 2003 on the restriction of the use of certain hazardous substances in electrical and electronic equipment

