



### Product Description

The RF3025 is a high isolation single-pole double-throw (SPDT) absorptive switch designed for general purpose switching applications requiring moderate insertion loss and power handling capability. It features single-bit control with operation as low as 3V. This GaAs pHEMT switch is housed in a compact 3mm, 16-pin, leadless QFN package.

### Features

- 10MHz to 6GHz Operation
- 0.5dB Insertion Loss at 1GHz
- 1.1dB Insertion Loss at 6GHz
- Terminated Off State
- 58dB Isolation at 1GHz
- 39dBm Isolation at 6GHz
- 3V Minimum Voltage
- 50dBm IP3 at 5V

### Applications

- Cellular Handset Applications
- Antenna Tuning Applications
- IEEE802.11b/g WLAN Applications
- Cellular Infrastructure Applications

#### Optimum Technology Matching® Applied

- GaAs HBT
- GaAs MESFET
- InGaP HBT
- SiGe BiCMOS
- Si BiCMOS
- SiGe HBT
- GaAs pHEMT
- Si CMOS
- Si BJT
- GaN HEMT
- InP HBT
- RF MEMS
- LDMOS

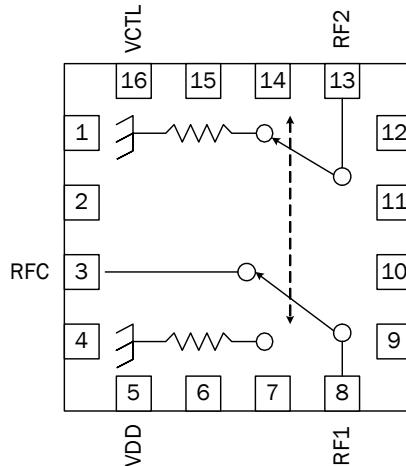

Parameter	Specification			Unit	Condition
	Min.	Typ.	Max.		
Insertion Loss		0.45		dB	Freq=10MHz to 1.0GHz
		0.5	0.8	dB	Freq=1.0GHz to 2.0GHz
		0.55		dB	Freq=2.0GHz to 3.0GHz
		0.8		dB	Freq=3.0GHz to 5.0GHz
		1.1		dB	Freq=5.0GHz to 6.0GHz
Return Loss		18		dB	Freq=10MHz to 1.0GHz, Freq=1.0GHz to 3.0GHz
		13		dB	Freq=3.0GHz to 6.0GHz
Return Loss into Off Port		14		dB	Freq=0.5GHz to 0.8GHz
		16		dB	Freq=0.8GHz to 1.0GHz
		17		dB	Freq=1.0GHz to 3.0GHz
		12		dB	Freq=3.0GHz to 6.0GHz
Isolation		58		dB	Freq=0.5GHz to 1.0GHz
	50	52		dB	Freq=1.0GHz to 2.0GHz
		48		dB	Freq=2.0GHz to 3.0GHz
		42		dB	Freq=3.0GHz to 5.0GHz
		39		dB	Freq=5.0GHz to 6.0GHz
PO.1dB*		30		dBm	Freq=1.8GHz
IP3*		50		dBm	Freq=0.5GHz to 2.5GHz, 1MHz spacing, 10dBm/tone
I <sub>DD</sub> , Supply Current		200	300	uA	
I <sub>C</sub> , Control Current		20		uA	
TON, TOFF		120		nS	50% of VCTRL to 10/90% of RF
TRISE, TFALL		35		nS	10/90% RF

Test Conditions: V<sub>DD</sub>=5V, 25 °C, 50Ω, with application circuit with 100pF DC blocking capacitors.  
 \*Note: Performance degrades below 50MHz.

## Absolute Maximum Ratings

Parameter	Rating	Unit
Supply Voltage $V_{DD}$	5.5	V
Control Voltage ( $V_C$ )	5.5	V
RF Input Power (on state)	32	dBm
RF Input Power (terminated port)	24	dBm
Operating Temp Range ( $T_L$ )	-40 to +85	°C
Storage Temp	-55 to +150	°C
ESD Rating (HBM)	Class 0	
Moisture Sensitivity Level	MSL2	



**Caution!** ESD sensitive device.

Exceeding any one or a combination of the Absolute Maximum Rating conditions may cause permanent damage to the device. Extended application of Absolute Maximum Rating conditions to the device may reduce device reliability. Specified typical performance or functional operation of the device under Absolute Maximum Rating conditions is not implied.

The information in this publication is believed to be accurate and reliable. However, no responsibility is assumed by RF Micro Devices, Inc. ("RFMD") for its use, nor for any infringement of patents, or other rights of third parties, resulting from its use. No license is granted by implication or otherwise under any patent or patent rights of RFMD. RFMD reserves the right to change component circuitry, recommended application circuitry and specifications at any time without prior notice.



RFMD Green: RoHS compliant per EU Directive 2002/95/EC, halogen free per IEC 61249-2-21, < 1000ppm each of antimony trioxide in polymeric materials and red phosphorus as a flame retardant, and <2% antimony in solder.

## Truth Table

$V_C$	RFC-RF1	RFC-RF2
0	OFF	ON
1	ON	OFF

Logic '0':  $0V < V_C \leq 1.0V$

Logic '1':  $2V < V_C \leq 5V$

## Evaluation Board Layout

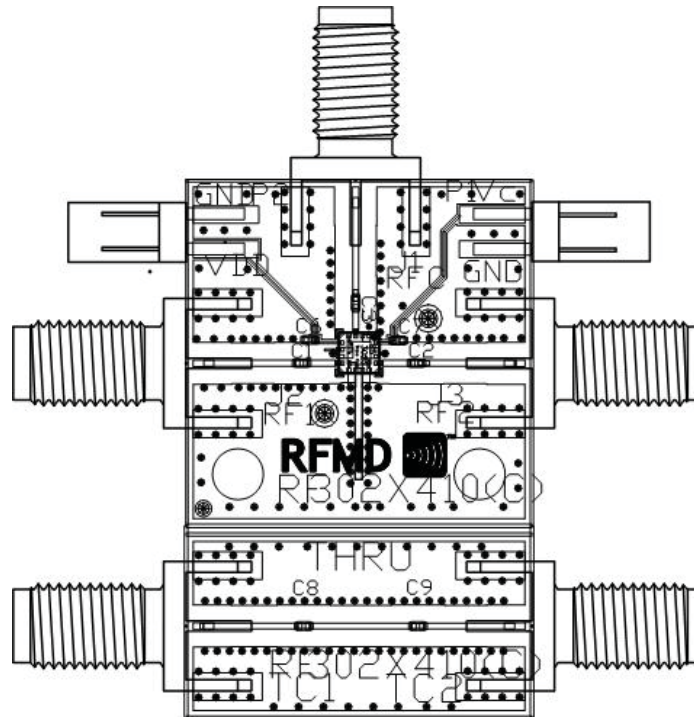

All Capacitors are 100pF

Evaluation Board Schematic

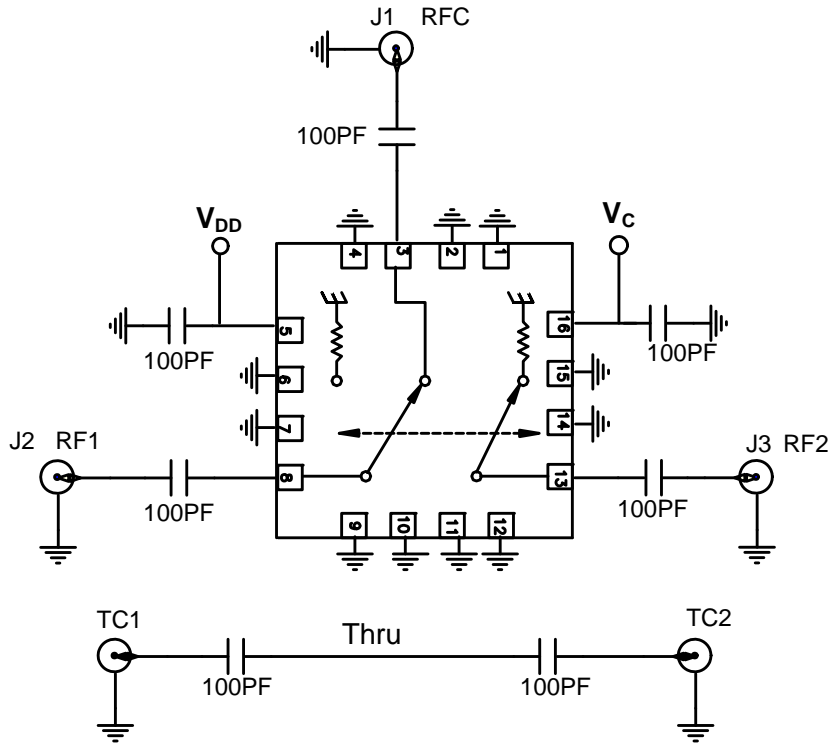

Pin	Function	Description
1	GND	Ground.
2	GND	Ground.
3	RFC	RF Common. External DC Block required.
4	GND	Ground.
5	VDD	Supply Voltage.
6	GND	Ground.
7	GND	Ground.
8	RF1	RF Port 1. External DC Block required.
9	GND	Ground.
10	GND	Ground.
11	GND	Ground.
12	GND	Ground.
13	RF2	RF Port 2. External DC Block required.
14	GND	Ground.
15	GND	Ground.
16	VC	Control Voltage.
17	Paddle	Ground.

## Package Drawing

Dimensions in millimeters

Refer to drawing posted at [www.rfmd.com](http://www.rfmd.com) for tolerances.

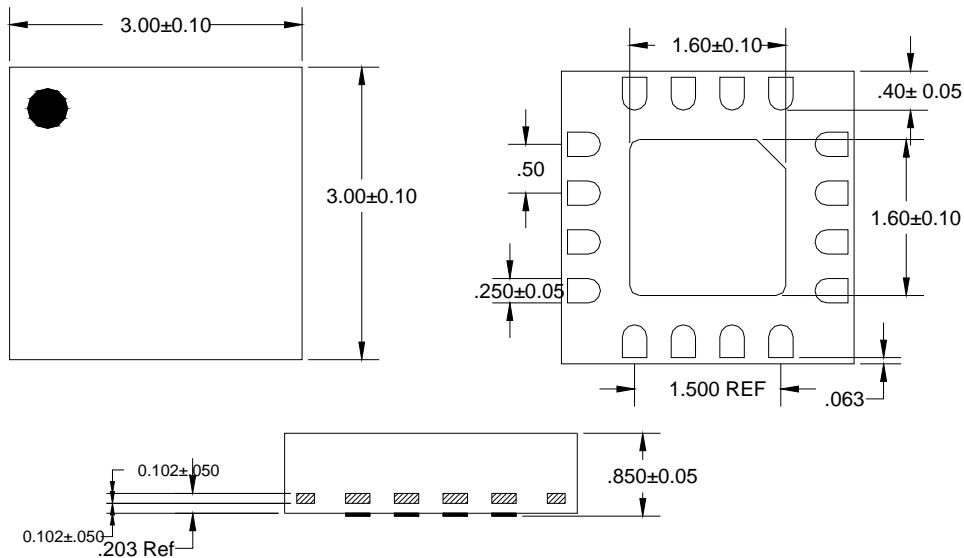

Typical Performance at 25 °C, V<sub>DD</sub> = 5V

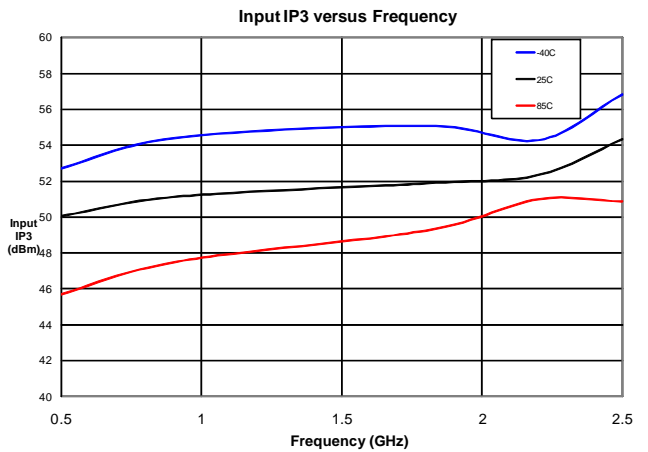
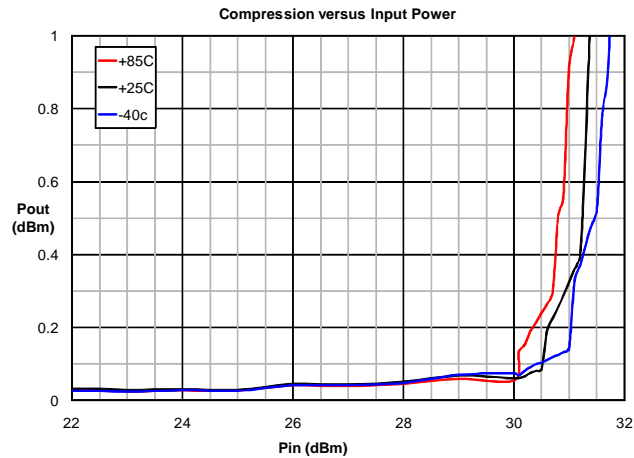
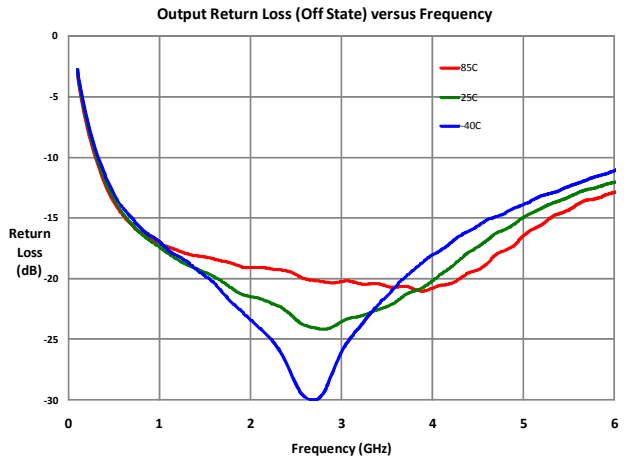
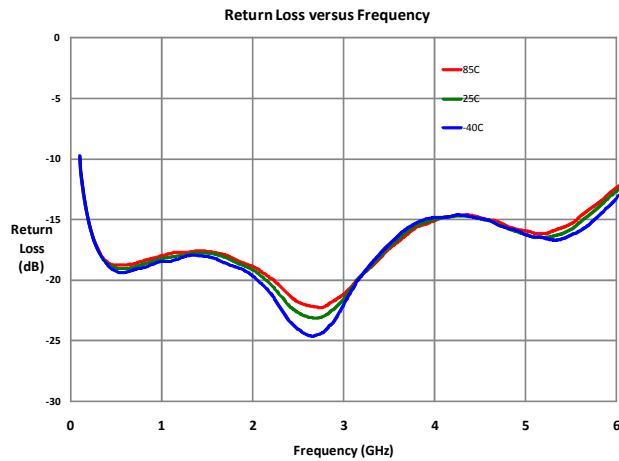
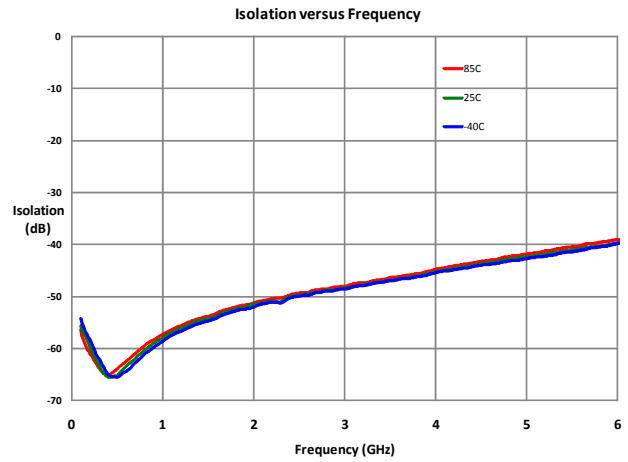
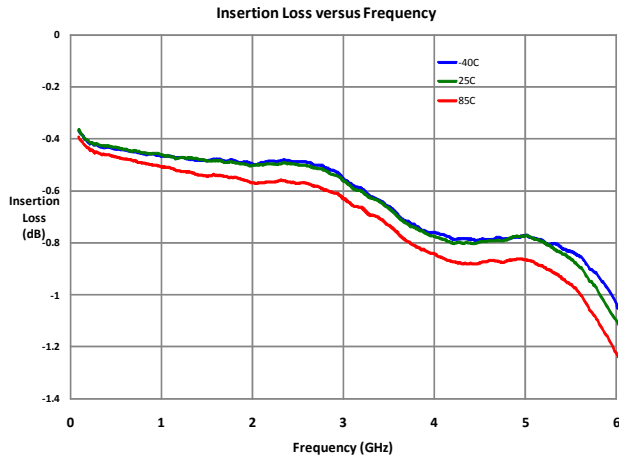

## Ordering Information

Ordering Code	Description
RF3025	Sample bag with 25 pieces
RF3025SR	7" Reel with 100 pieces
RF3025TR7	7" Reel with 2500 pieces
RF3025PCK-410	500MHz to 4000MHz PCBA with 5-piece sample bag