



### Features

- 500MHz to 2000MHz
- +44.0dBm Output IP3
- +14.0dB Gain at 850MHz
- +11.4dBm Input P1dB at 850MHz
- 3.4dB Noise Figure at 850MHz
- Single 5V Power Supply

### Applications

- Basestation Applications
- Cellular and PCS Systems
- CDMA, W-CDMA Systems
- GSM/EDGE Systems
- Final PA for Low-Power Applications

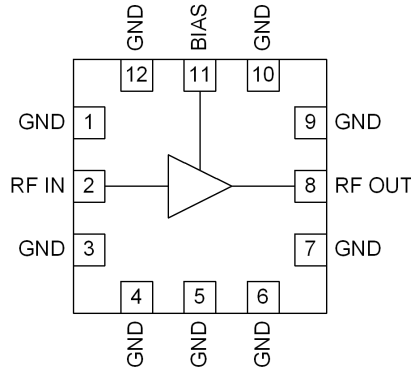

Functional Block Diagram

### Product Description

The RF3223 is a high-efficiency GaAs Heterojunction Bipolar Transistor (HBT) amplifier packaged in a low-cost surface-mount package. This amplifier is ideal for use in applications requiring high-linearity and low noise figure over the 500MHz to 3GHz frequency range. The RF3223 operates from a single 5V power supply, and is assembled in an economical 3mmx3mm QFN package.

### Ordering Information

RF3223	Low Noise, Linear Amplifier High Linearity/Driver Amplifier
RF3223PCBA-41X	Fully Assembled Evaluation Board

### Optimum Technology Matching® Applied

- |  |                                      |                                     |                                   |
|--|--------------------------------------|-------------------------------------|-----------------------------------|
| <input checked="" type="checkbox"/> GaAs HBT | <input type="checkbox"/> SiGe BiCMOS | <input type="checkbox"/> GaAs pHEMT | <input type="checkbox"/> GaN HEMT |
| <input type="checkbox"/> GaAs MESFET         | <input type="checkbox"/> Si BiCMOS   | <input type="checkbox"/> Si CMOS    | <input type="checkbox"/> RF MEMS  |
| <input type="checkbox"/> InGaP HBT           | <input type="checkbox"/> SiGe HBT    | <input type="checkbox"/> Si BJT     | <input type="checkbox"/> LDMOS    |

## Absolute Maximum Ratings

Parameter	Rating	Unit
RF Input Power	+20	dBm
Device Voltage	-0.5 to +6.0	V
Device Current	200	mA
Operating Temperature	-40 to +85	°C
Storage Temperature	-40 to +150	°C

Note 1: Max operating voltage is 5V.

Note 2: Max operating current is 160mA for backed-off applications. Higher current compressed applications require dissipated power <0.9W.



Caution! ESD sensitive device.

Exceeding any one or a combination of the Absolute Maximum Rating conditions may cause permanent damage to the device. Extended application of Absolute Maximum Rating conditions to the device may reduce device reliability. Specified typical performance or functional operation of the device under Absolute Maximum Rating conditions is not implied.

RoHS status based on EU Directive 2002/95/EC (at time of this document revision).

The information in this publication is believed to be accurate and reliable. However, no responsibility is assumed by RF Micro Devices, Inc. ("RFMD") for its use, nor for any infringement of patents, or other rights of third parties, resulting from its use. No license is granted by implication or otherwise under any patent or patent rights of RFMD. RFMD reserves the right to change component circuitry, recommended application circuitry and specifications at any time without prior notice.

Parameter	Specification			Unit	Condition
	Min.	Typ.	Max.		
<b>Overall</b>					V <sub>CC</sub> =5V, RF <sub>IN</sub> =-10dBm, Freq=850MHz, with Temp=25°C unless otherwise noted.
<b>AC Specifications</b>					
Frequency				MHz	
Gain (Small Signal)	12	14.0	15.0	dB	
Reverse Isolation		21			
Output IP3	41	45		dBm	F <sub>1</sub> = 850 MHz, F <sub>2</sub> = 851 MHz
Output P1dB	23	+24.5		dBm	
Noise Figure		3.4		dB	
<b>Thermal</b>					
Theta <sub>JC</sub>		75		°C/W	
Maximum Measured Junction Temperature at DC Bias Conditions		145		°C	T <sub>CASE</sub> = +85 °C. I <sub>CC</sub> = 160 mA V <sub>CC</sub> = 5.0V
Mean Time To Failures		>100		years	T <sub>CASE</sub> = +85 °C
<b>DC Specifications</b>					
Device Voltage		5.0		V	
Operating Current Range	110	150	160	mA	V <sub>CC</sub> = 5V

Note: The RF3223 must be operated at or below 160mA in order to achieve the thermal performance listed above.

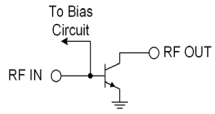
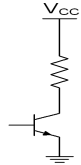
Pin	Function	Description	Interface Schematic
1	GND	Ground connection.	
2	RF IN	RF input pin. This pin is not internally DC-blocked. A DC blocking capacitor suitable for the frequency of operation should be used.	
3	GND	Ground connection.	
4	GND	Ground connection.	
5	GND	Ground connection.	
6	GND	Ground connection.	
7	GND	Ground connection.	
8	RF OUT	Amplifier output pin. This pin is an open-collector output. It must be biased to $V_{CC}$ through a choke or matching inductor. This pin is typically matched to $50\Omega$ with a shunt bias/matching inductor and series blocking/matching capacitor. Refer to application schematics.	See pin 2.
9	GND	Ground connection.	
10	GND	Ground connection.	
11	BIAS	This pin is used to control the bias current. An external resistor may be used to set the bias current for any $V_{PD}$ voltage. Allows for trade-offs between IP3 versus noise figure and $T_{MAX}$ .	
12	GND	Ground connection.	
Pkg Base	GND	Ground connection. Vias to ground required under the package base.	

**Package Drawing**

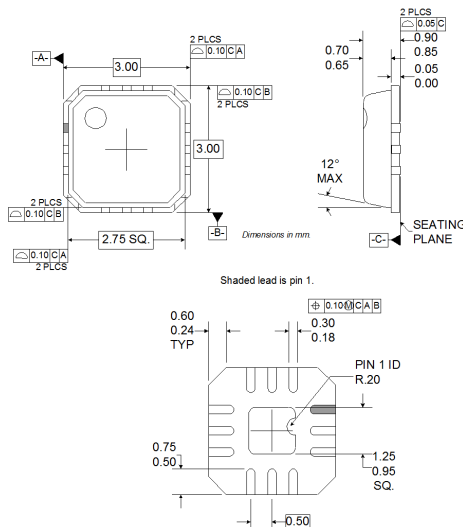

## Application Schematic - 850 MHz

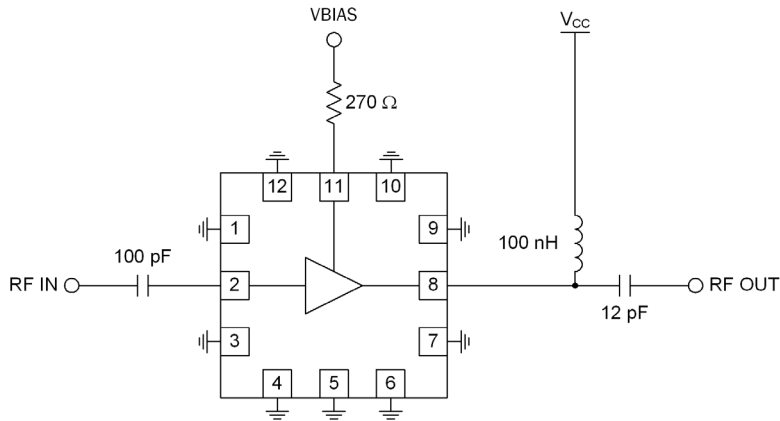

**Evaluation Board Schematic**

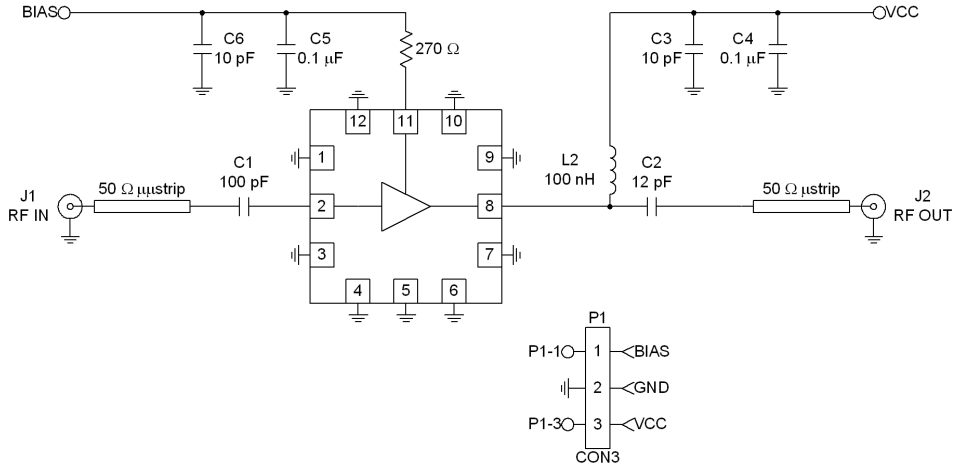

## Evaluation Board Layout

### Board Size 1.5" x 1.5"

Board Thickness 0.032", Board Material FR-4

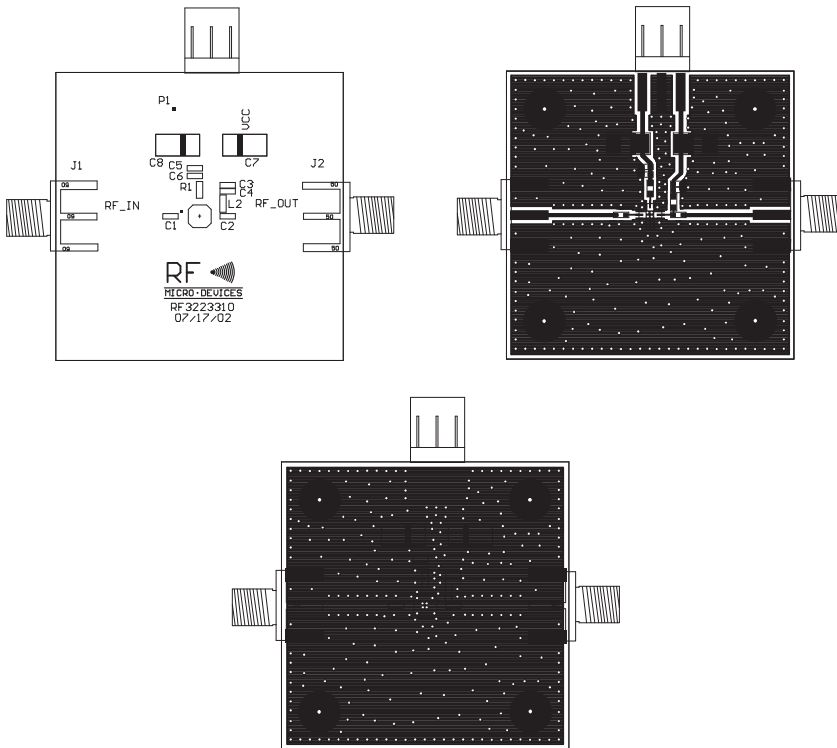

**$I_{CC}$  versus  $V_{CC}$  Across Temperature**

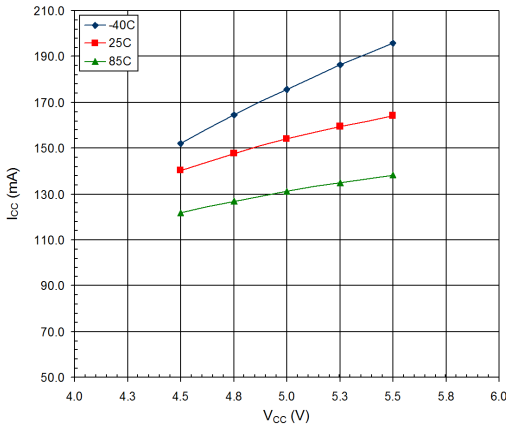

**Gain versus Frequency Across Temperature ( $V_{CC}=5.0V$ )**

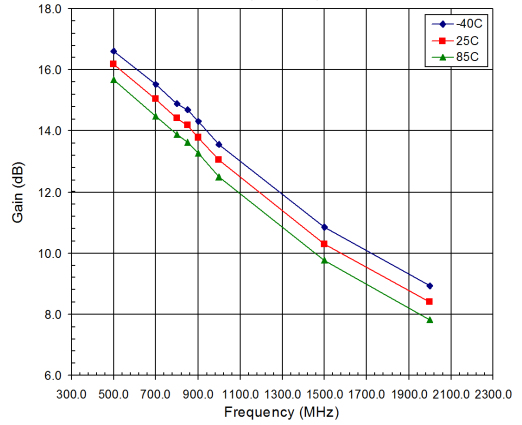

**OIP3 versus Frequency Across Temperature ( $V_{CC}=5.0V$ )**

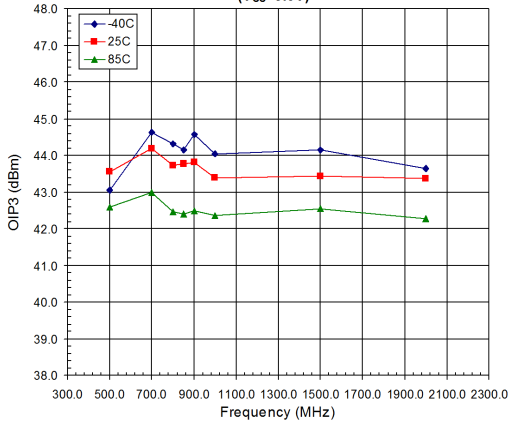

**Output P1dB versus Frequency Across Temperature ( $V_{CC}=5.0V$ )**

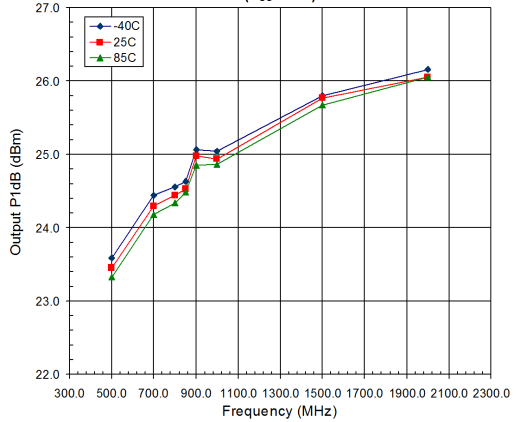

**Input VSWR versus Frequency Across Temperature ( $V_{CC}=5.0V$ )**

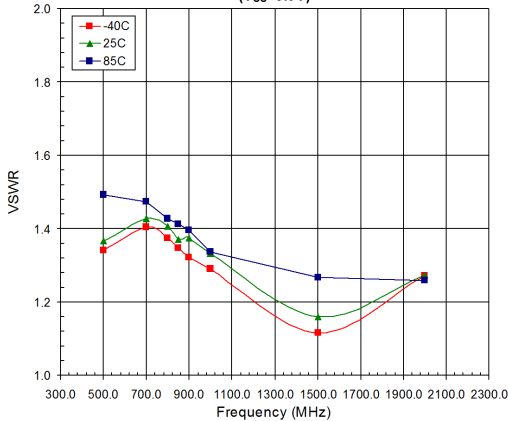

**Output VSWR versus Frequency Across Temperature ( $V_{CC}=5.0V$ )**

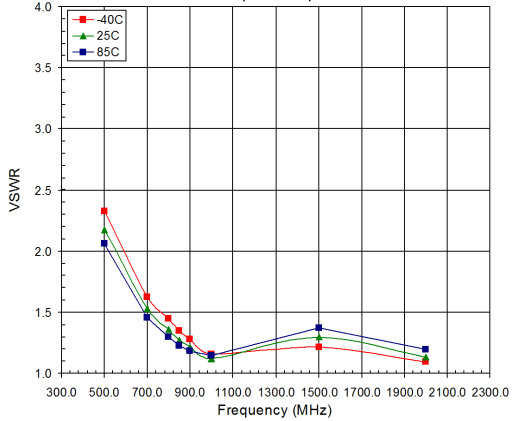

# RF3223



rfmd.com