

Package Style: Module, 10-Pin, 3mmx3mmx1.0mm



Features

- HSDPA Compliant
- Low Voltage Positive Bias Supply (3.0V to 4.2V)
- +28.0dBm Linear Output Power (+26.5dBm HSDPA)
- High Efficiency Operation 43% at $P_{OUT} = +28.0\text{dBm}$
- Internal Voltage Regulator Eliminates the Need for External Reference Voltage (V_{REF})
- 2-Mode Power States with Digital Control Interface
- Supports DC/DC Converter Operation
- Integrated Power Coupler
- Integrated Blocking and Collector Decoupling Capacitors

Applications

- WCDMA/HSDPA Wireless Data Cards

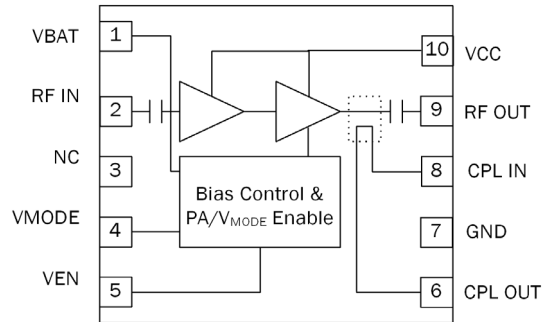

Functional Block Diagram

Product Description

The RF3702 is a high-power, high-efficiency, linear power amplifier designed for use as the final RF amplifier in 3V, 50Ω W-CDMA mobile cellular equipment and spread-spectrum systems. This PA is developed for UMTS Band 2 which operates in the 1850MHz to 1910MHz frequency band. The RF3702 has a digital control pin which enables a low power mode to reduce amplifier gain at lower power levels. The part also has an integrated directional coupler which eliminates the need for an external discrete coupler at the output. The RF3702 is fully HSDPA-compliant and is assembled in a 10-pin, 3mmx3mm module.

Ordering Information

RF3702 3V W-CDMA Band 2 Linear PA Module
 RF3702PCBA-410 Fully Assembled Evaluation Board

Optimum Technology Matching® Applied

- | | | | |
|---|--------------------------------------|---|-----------------------------------|
| <input type="checkbox"/> GaAs HBT | <input type="checkbox"/> SiGe BiCMOS | <input type="checkbox"/> GaAs pHEMT | <input type="checkbox"/> GaN HEMT |
| <input type="checkbox"/> GaAs MESFET | <input type="checkbox"/> Si BiCMOS | <input checked="" type="checkbox"/> Si CMOS | <input type="checkbox"/> RF MEMS |
| <input checked="" type="checkbox"/> InGaP HBT | <input type="checkbox"/> SiGe HBT | <input type="checkbox"/> Si BJT | <input type="checkbox"/> LDMOS |

Absolute Maximum Ratings

Parameter	Rating	Unit
Supply Voltage in Standby Mode	5.5	V
Supply Voltage in Idle Mode	5.5	V
Supply Voltage in Operating Mode, 50Ω Load	5.5	V
Supply Voltage, V _{BAT}	5.5	V
Control Voltage, V _{MODE}	5.5	V
Control Voltage, V _{EN}	5.5	V
RF - Input Power	+10	dBm
RF - Output Power	+30	dBm
Output Load VSWR (Ruggedness)	10:1	
Operating Ambient Temperature	-30 to +110	°C
Storage Temperature	-55 to +150	°C



Caution! ESD sensitive device.

Exceeding any one or a combination of the Absolute Maximum Rating conditions may cause permanent damage to the device. Extended application of Absolute Maximum Rating conditions to the device may reduce device reliability. Specified typical performance or functional operation of the device under Absolute Maximum Rating conditions is not implied.

RoHS status based on EU Directive 2002/95/EC (at time of this document revision).

The information in this publication is believed to be accurate and reliable. However, no responsibility is assumed by RF Micro Devices, Inc. ("RFMD") for its use, nor for any infringement of patents, or other rights of third parties, resulting from its use. No license is granted by implication or otherwise under any patent or patent rights of RFMD. RFMD reserves the right to change component circuitry, recommended application circuitry and specifications at any time without prior notice.

Parameter	Specification			Unit	Condition
	Min.	Typ.	Max.		
Recommended Operating Conditions					
Operating Frequency Range	1850		1910	MHz	
V _{BAT}	+3.0	+3.2	+4.2	V	
V _{CC}	+0.5	+3.2 ¹	+4.2	V	
V _{EN}	0		0.5	V	PA disabled.
	1.35	1.80	3.10	V	PA enabled.
V _{MODE}	0		0.5	V	Logic "low".
	1.35	1.80	3.10	V	Logic "high".
P _{OUT}					
Maximum Linear Output (HPM)	28.0 ^{2,3}			dBm	High Power Mode (HPM)
Maximum Linear Output (LPM)	16 ^{2,3}			dBm	Low Power Mode (LPM)
Ambient Temperature	-20	+25	+85	°C	
Notes:					
¹ Minimum V _{CC} for max P _{OUT} indicated. V _{CC} down to 0.5V may be used for backed-off power when using DC/DC converter to conserve battery current.					
² For operation at V _{CC} =+3.0V, derate P _{OUT} by 0.5 dB.					
³ P _{OUT} is specified for 3GPP (Voice) modulation. For HSDPA operation, derate P _{OUT} by 1.5dB: HSDPA Configuration: βc=12, βd=15, βhs=24					

Parameter	Specification			Unit	Condition
	Min.	Typ.	Max.		
Electrical Specifications					T = +25 °C, V _{CC} = V _{BAT} = +3.2V, V _{EN} = +1.8V, 50Ω system, unless otherwise specified.
Gain	26	28		dB	HPM, P _{OUT} = 28.0dBm
		14.5		dB	LPM, P _{OUT} ≤ 16.0dBm
Gain Linearity		±0.2		dB	HPM, 16.0dBm ≤ P _{OUT} ≤ 28.0dBm
ACLR - 5MHz Offset		-40		dBc	HPM, P _{OUT} = 28.0dBm
		-40		dBc	LPM, P _{OUT} = 16.0dBm
ACLR - 10MHz Offset		-55		dBc	HPM, P _{OUT} = 28.0dBm
		-58		dBc	LPM, P _{OUT} = 16.0dBm
PAE Without DC/DC Converter		43		%	HPM, P _{OUT} = 28.0dBm
		8		%	LPM, P _{OUT} = 16.0dBm
Current Drain		140		mA	LPM, P _{OUT} = 16.0dBm
Quiescent Current		80		mA	HPM, DC only
Enable Current		0.1		mA	Source or sink current. V _{EN} = 1.8V.
Mode Current (I _{MODE})		0.1		mA	Source or sink current. V _{MODE} = 1.8V.
Leakage Current		1.0	10.0	μA	DC only. V _{CC} = V _{BAT} = 4.2V, V _{EN} = V _{MODE} = 0.5V.
Noise Power in Receive Band		-136		dBm/Hz	All power modes, measured at duplex offset frequency (FTX + 80MHz). Rx: 1930MHz to 1990MHz, P _{OUT} ≤ 28.0dBm
Input Impedance		1.8:1		VSWR	No ext. matching, P _{OUT} ≤ 28dBm, all modes.
Harmonic, 2FO		-22		dBm	P _{OUT} ≤ 28.0dBm, all power modes.
Harmonic, 3FO		-30		dBm	P _{OUT} ≤ 28.0dBm, all power modes.
Spurious Output Level			-70	dBc	All spurious, P _{OUT} ≤ 28dBm, all conditions, load VSWR ≤ 6:1, all phase angles.
Insertion Phase Shift	-30		+30	°	Phase shift at 16dBm when switching from HPM to LPM.
DC Enable Time			10	μs	DC only. Time from V _{EN} = high to stable idle current (90% of steady state value).
RF Rise/Fall Time			6	μs	P _{OUT} ≤ 28.0dBm, all modes. 90% of target, DC settled prior to RF.
Coupling Factor		-20		dB	P _{OUT} ≤ 28.0dBm, all modes.
Coupling Accuracy - Temp/Voltage		±0.5		dB	P _{OUT} ≤ 28.0dBm, all modes. -20 °C ≤ T ≤ 85 °C, 3.0V ≤ V _{CC} & V _{BAT} ≤ 4.2V, referenced to 25 °C, 3.2V conditions.
Coupling Accuracy - VSWR		±0.25		dB	P _{OUT} ≤ 28dBm, all modes, load VSWR = 2.5:1, ±0.3dB accuracy corresponds to 22 dB directivity.

Pin	Function	Description
1	VBAT	Supply voltage for bias circuitry.
2	RF IN	RF input internally matched to 50Ω and DC blocked. The RF input matching circuit has a shunt inductor to ground which would short any DC voltage placed on this pin.
3	NC	No connection.
4	VMODE	Digital control input for power mode selection (see Operating Modes truth table).
5	VEN	Digital control input for PA enable and disable (see Operating Modes truth table).
6	CPL_OUT	Coupler output.
7	GND	This pin must be grounded.
8	CPL_IN	Coupler input used for cascading couplers in series. Terminate this pin with a 50Ω resistor if not connected to another coupler.
9	RF OUT	RF output internally matched to 50Ω and DC blocked.
10	VCC	Supply voltage for the first and second stage amplifiers, which can be connected to battery supply or output of DC-DC converter.
Pkg Base	GND	Ground connection. The package backside should be soldered to a topline ground pad connecting to the PCB ground plane with multiple ground vias. The pad should have a low thermal resistance and low electrical impedance to the ground plane.

Operating Mode Truth Table

V _{EN}	V _{MODE}	V _{BAT}	V _{CC}	Conditions/Comments
Low	Low	3.0V to 4.2V	3.0V to 4.2V	Power down mode
Low	X	3.0V to 4.2V	3.0V to 4.2V	Standby Mode
High	Low	3.0V to 4.2V	3.0V to 4.2V	High power mode
High	High	3.0V to 4.2V	3.0V to 4.2V	Low power mode

Package Drawing

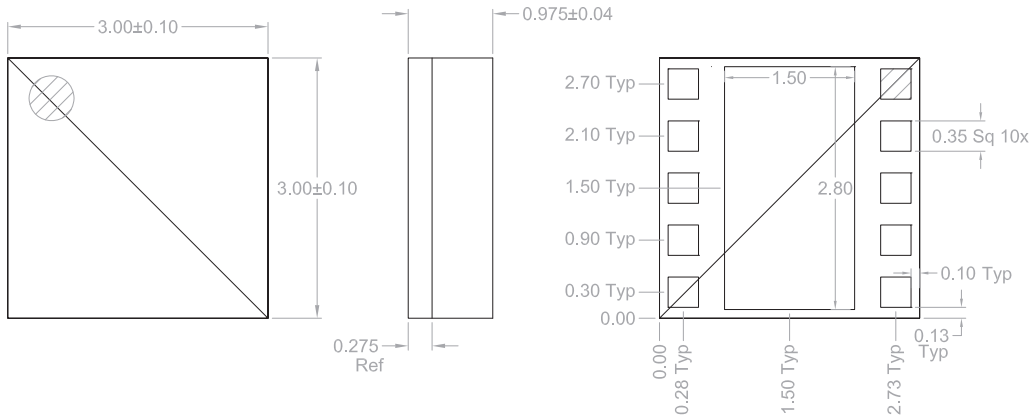

Notes:

1. Shaded area represents Pin 1 location
2. Defining I/O Pad Center:
To define center of the I/O pad opening, draw a right triangle in one corner of the I/O pad
Then take the center of the hypotenuse to determine center of I/O pad

Preliminary Application Schematic

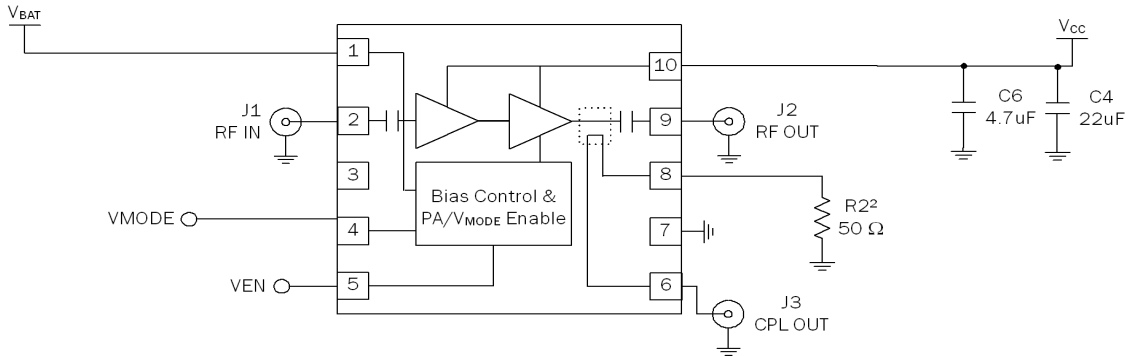

NOTES:

1. VCC and VBAT are connected together if DC-DC converter is not used.
2. 50 Ω resistor will be removed if pin 8 is connected to another coupler.

PCB Design Requirements

PCB Surface Finish

The PCB surface finish used for RFMD's qualification process is electroless nickel, immersion gold. Typical thickness is 3µinch to 8µinch gold over 180µinch nickel.

PCB Land Pattern Recommendation

PCB land patterns for RFMD components are based on IPC-7351 standards and RFMD empirical data. The pad pattern shown has been developed and tested for optimized assembly at RFMD. The PCB land pattern has been developed to accommodate lead and package tolerances. Since surface mount processes vary from company to company, careful process development is recommended.

PCB Metal Land Pattern

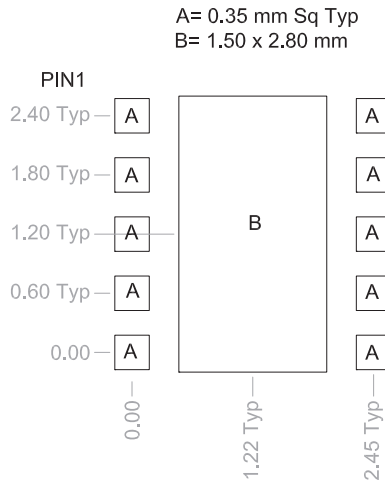

Figure 1. PCB Metal Land Pattern (Top View)

PCB Solder Mask Pattern

Liquid Photo-Imageable (LPI) solder mask is recommended. The solder mask footprint will match what is shown for the PCB metal land pattern with a 2mil to 3mil expansion to accommodate solder mask registration clearance around all pads. The center-grounding pad shall also have a solder mask clearance. Expansion of the pads to create solder mask clearance can be provided in the master data or requested from the PCB fabrication supplier.

A= 0.49 mm Sq Typ
 B= 1.64 x 2.94 mm

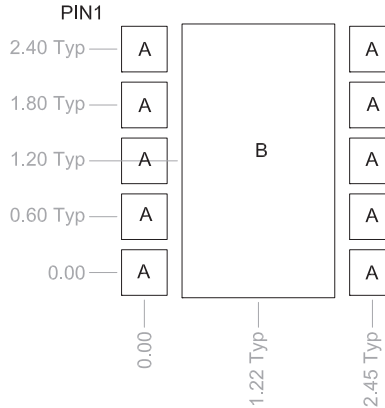

Figure 2. PCB Solder Mask Pattern (Top View)

Thermal Pad and Via Design

The PCB land pattern has been designed with a thermal pad that matches the die paddle size on the bottom of the device.

Thermal vias are required in the PCB layout to effectively conduct heat away from the package. The via pattern has been designed to address thermal, power dissipation and electrical requirements of the device as well as accommodating routing strategies.

The via pattern used for the RFMD qualification is based on thru-hole vias with 0.203mm to 0.330mm finished hole size on a 0.5mm to 1.2mm grid pattern with 0.025mm plating on via walls. If micro vias are used in a design, it is suggested that the quantity of vias be increased by a 4:1 ratio to achieve similar results.